



150kHz, 2A PWM Buck DC/DC Converter

Features

- Output voltage: Fixed 3.3V, 5V, 12V and adjustable output (1.23V to 38.5V) versions.
- Fixed switching frequency, 150KHz ±15%.
- Voltage mode non-synchronous PWM control.
- Thermal-shutdown and current-limit protection.
- ON/OFF shutdown control input.
- Short Circuit Protection (SCP).
- Operating voltage up to 40V.
- Output load current up to 2A.
- Low-power standby mode.
- Built-in switching transistor on chip.
- SO-8 package
- RoHS-compliant, halogen-free.

Description

The APE1707-HF-3 series consists of step-down DC-DC converters with the ability to drive a 2A load without an external switching transistor, saving board space. The external shutdown function can be controlled by logic level signals to put the device in standby mode. The internal compensation allows feedback control for good line and load regulation without external components. Thermal shutdown protection prevents damage from excessive operating temperatures and output current limiting protects the device from damage. Excess current when VFB is below 0.5V results in reduced switching frequency. The APE1707-HF-3 series operate at a switching frequency of 150kHz, allowing smaller sized filter components than with lower frequencies.

The APE1705-HF-3 series are available with an adjustable output voltage, or fixed output voltages of 3.3V, 5V or 12V, and are supplied in an SO-8 package.

Typical Application

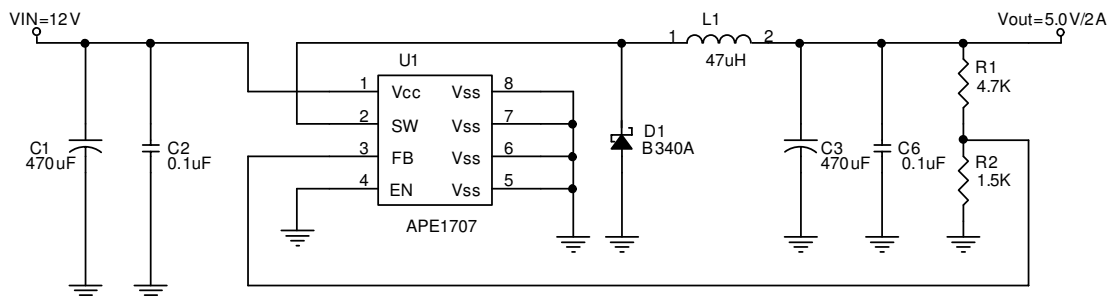

Ordering information

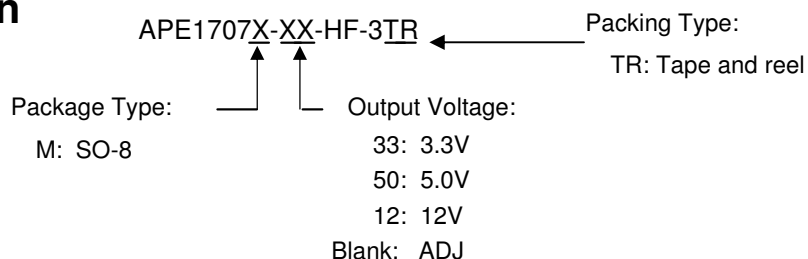

Examples:

APE1707M-33-HF-3TR 3.3V fixed output in RoHS-compliant, halogen-free SO-8, shipped on tape and reel (3000 pcs/reel).

APE1707M-HF-3TB adjustable output in RoHS-compliant, halogen-free SO-8, shipped on tape and reel (3000 pcs/reel).



Absolute Maximum Ratings (at $T_A = 25^\circ\text{C}$)

Characteristics	Symbol	Rating	Unit
Maximum Supply Voltage	V_{CC}	+45	V
ON/OFF Pin Input Voltage	V_{EN}	-0.3 to 40	V
Feedback Pin Voltage	V_{FB}	-0.3 to 12	V
Output Voltage to Ground	V_{OUT}	0.8 to 45V	V
Power Dissipation Internally limited	PD	$(T_J - T_A) / \theta_{JA}$	W
Storage Temperature Range	T_{ST}	-65 to +150	$^\circ\text{C}$
Operating Junction Temperature Range	T_J	-20 to +125	$^\circ\text{C}$
Operating Supply Voltage	V_{OP}	+4.5 to +40	V
Thermal Resistance from Junction to case	θ_{JC}	20	$^\circ\text{C/W}$
Thermal Resistance from Junction to ambient	θ_{JA}	60	$^\circ\text{C/W}$

Note: R_{thJA} is measured with a PCB copper area (must be connected to V_{SS} pins) of approximately 1.5 in² (multi-layer).

Electrical Characteristics

(Unless otherwise specified, $T_A=25^\circ\text{C}$, $V_{CC}=12\text{V}$ for 3.3V, 5V, adjustable version and $V_{CC}=18\text{V}$ for the 12V version. $I_{LOAD} = 0.2\text{A}$)

Characteristics	Symbol	Conditions	Min	Typ	Max	Units
Quiescent Current	I_Q	$V_{FB}=12\text{V}$ force driver off		4	8	mA
Feedback bias current	I_{FB}	$V_{FB}=1.3\text{V}$ (Adjustable version only)		-10	-50	nA
Shutdown supply Current	I_{SD}	EN pin=5V $V_{CC}=40\text{V}$		100	200	uA
Oscillator frequency	F_{OSC}		127	150	173	kHz
Oscillator frequency of short circuit protect	F_{SCP}	(Adjustable) When $V_{FB}<0.5\text{V}$		50		kHz
		(Fixed)When $< V_{OUT} * 40\%$		50		kHz
Max. Duty Cycle (ON)	DC	$V_{FB}=0\text{V}$ force driver on		100		%
Min. Duty Cycle (OFF)		$V_{FB}=12\text{V}$ force driver off		0		
Current limit	I_{CL}	Pear current, No outside circuit $V_{FB}=0\text{V}$ force driver on	2.5			A
Load Regulation($\Delta V_{OUT}/V_{OUT}$)	ΔV_{OUT}	$I_{OUT} = 0.2$ to 2A	-	0.6	1.2	%
Saturation voltage	V_{SAT}	$I_{OUT}=2\text{A}$, No outside circuit $V_{FB}=0\text{V}$ force driver on		1.2	1.4	V
SW pin=0V	SW pin leakage current	No outside circuit $V_{FB}=12\text{V}$ force driver off			-200	uA
SW pin=-0.8V		$V_{CC}=40\text{V}$ force driver off		-5		mA
EN pin logic input threshold voltage	V_{IL}	Low (regulator ON)	-	1.3	0.6	V
	V_{IH}	High (regulator OFF)	2.0		-	
EN pin logic input current	I_H	$V_{EN}=2.5\text{V}$ (OFF)		-0.1	-10	uA
EN pin input current	I_L	$V_{EN}=0.5\text{V}$ (ON)		-0.01	-1	
Thermal shutdown Temp	TSD			135		$^\circ\text{C}$



Electrical Characteristics (cont.)

Version	Characteristics	Symbol	Conditions	Min	Typ	Max	Units
APE1707-ADJ	Output Feedback voltage	V_{FB}	$I_{LOAD} = 0.2A$ V_{OUT} programmed for 3.3V	1.193	1.23	1.267	V
	Efficiency	η	$V_{CC} = 12V, I_{LOAD} = 2A$		79		%
APE1707-3.3V	Output voltage	V_{OUT}	$I_{LOAD} = 0.2A$	3.20	3.30	3.40	V
	Efficiency	η	$V_{CC} = 12V, I_{LOAD} = 2A$		80		%
APE1707-5.0V	Output voltage	V_{OUT}	$I_{LOAD} = 0.2A$	4.85	5.00	5.15	V
	Efficiency	η	$V_{CC} = 12V, I_{LOAD} = 2A$		84		%
APE1707-12V	Output voltage	V_{OUT}	$I_{LOAD} = 0.2A$	11.64	12.0	12.36	V
	Efficiency	η	$V_{CC} = 15V, I_{LOAD} = 2A$		90		%

THIS PRODUCT IS SENSITIVE TO ELECTROSTATIC DISCHARGE, PLEASE HANDLE WITH CAUTION.
 USE OF THIS PRODUCT AS A CRITICAL COMPONENT IN LIFE SUPPORT OR OTHER SIMILAR SYSTEMS IS NOT AUTHORIZED.
 APEC DOES NOT ASSUME ANY LIABILITY ARISING OUT OF THE APPLICATION OR USE OF ANY PRODUCT OR CIRCUIT DESCRIBED HEREIN; NEITHER DOES IT CONVEY ANY LICENSE UNDER ITS PATENT RIGHTS, NOR THE RIGHTS OF OTHERS.
 APEC RESERVES THE RIGHT TO MAKE CHANGES WITHOUT FURTHER NOTICE TO ANY PRODUCTS HEREIN TO IMPROVE RELIABILITY, FUNCTION OR DESIGN.



Block Diagram

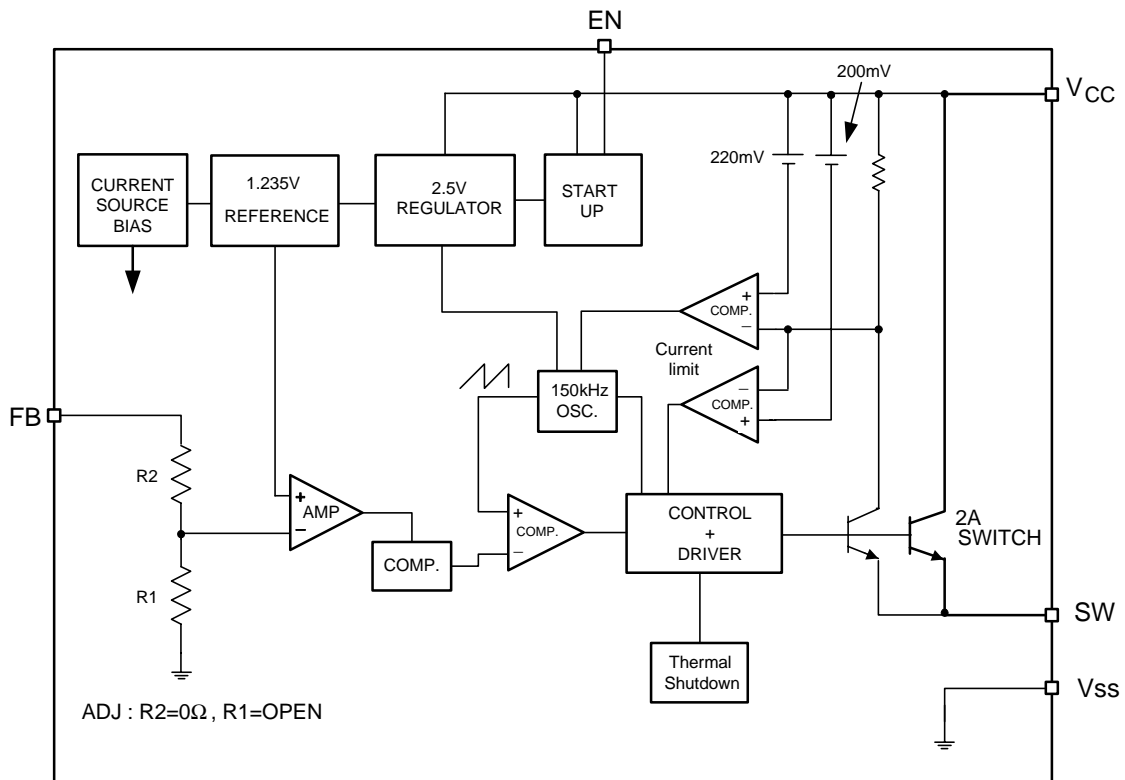

Pin Assignment

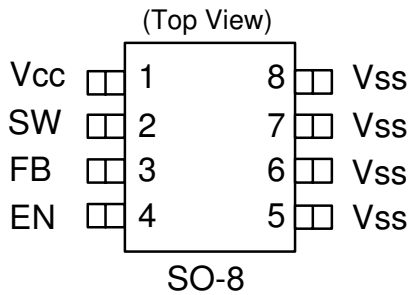

Name	Description
V _{CC}	Operating voltage input
SW	Switching output
FB	Output voltage feedback control
EN	ON/OFF Shutdown
V _{SS}	GND pin



Typical Application Circuits

(1) Adjustable Output Voltage Version

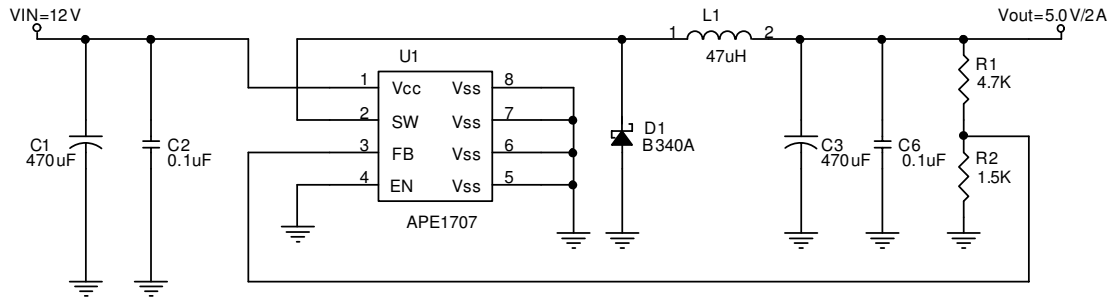

(2) Adjustable Output Voltage Version With Delayed Startup

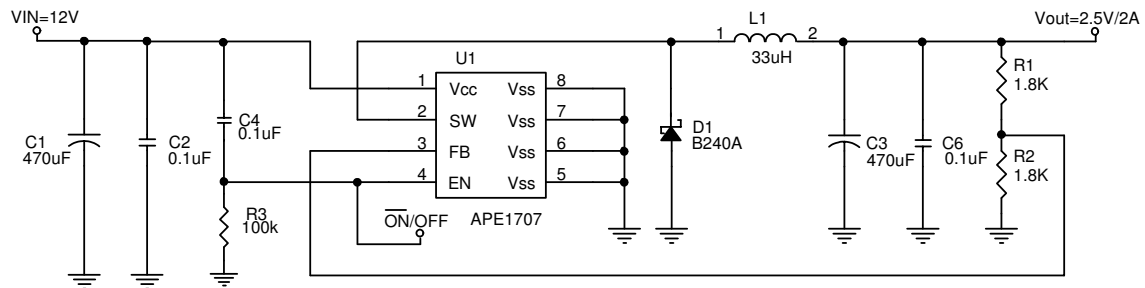

$$V_{out} = V_{FB} \times \left(1 + \frac{R1}{R2}\right), \quad V_{FB} = 1.23V, \quad R2 = 0.47k\Omega \sim 3k\Omega$$

Table 1: Resistor selection for output voltage setting

V _{OUT}	R2	R1
5V	1.5k	4.7k
	1.8k	5.6k
3.3V	1.5k	2.5k
	1.8k	3.0k
2.5V	1.8k	1.8k
1.8V	1.8k	0.82k

L1 recommended value (I _{OUT} =2A)				
V _{OUT}	2.5V	3.3V	5V	12V
V _{IN} =12V	33uH	33uH	47uH	NA
V _{IN} =24V	33uH	33uH	47uH	68uH



Typical Application Circuits (cont.)

(3) Fixed Output Voltage Version

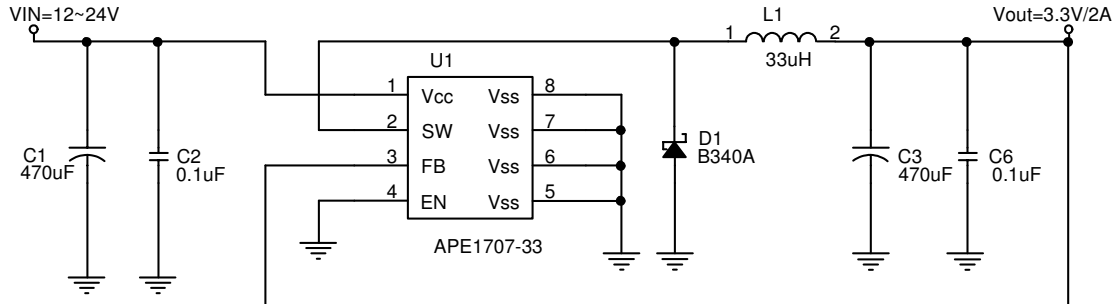

(4) Inverting -5V Regulator with Delayed Startup

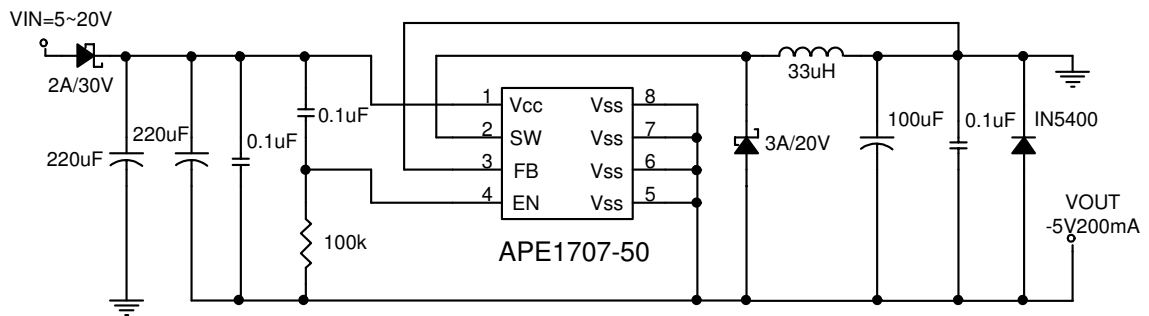



Functional Description

Pin Functions

V_{cc}

This is the positive input supply for the IC switching regulator. A suitable input bypass capacitor must be present at this pin to minimize voltage transients and to supply the switching currents needed by the regulator.

V_{ss}

Circuit ground.

SW

Internal switch. The voltage at this pin switches between $(+V_{CC} - V_{SAT})$ and approximately $-0.5V$, with a duty cycle of approximately V_{OUT} / V_{CC} . To minimize coupling to sensitive circuitry, the PC board copper area connected to this pin should be minimized.

Feedback

Senses the regulated output voltage to complete the feedback loop.

EN

Allows the switching regulator circuit to be shutdown using logic level signals thus dropping the total input supply current to approximately 100uA. Pulling this pin below a threshold voltage of approximately 1.3V turns the regulator on, and pulling this pin above 1.3V (up to a maximum of V_{cc}) shuts the regulator down. If this shutdown feature is not needed, the EN pin can be wired to the ground pin.

Thermal Considerations

The SO-8 package needs a heat sink under most conditions. The size of the heat sink depends on the input voltage, the output voltage, the load current and the ambient temperature. The APE1707 junction temperature rises above ambient temperature for a 2A load and different input and output voltages.

The data for these curves was taken with the APE1707 (in SO-8 package) operating as a buck-switching regulator in an ambient temperature of 25°C (still air). These temperature increments are all approximate and are affected by many factors. Higher ambient temperatures require more heatsinking.



Functional Description (cont.)

For the best thermal performance, wide copper traces and generous amounts of printed circuit board copper (needs to be connected to the V_{SS} pins) should be used in the board layout, (One exception is the SW (switch) pin, which should not have large areas of copper.) Large areas of copper provide the best transfer of heat (lower thermal resistance) to the surrounding air, and moving air lowers the thermal resistance even further.

Package thermal resistance and junction temperature increments are all approximate. The increments are affected by a lot of factors. Some of these factors include board size, shape, thickness, position, location, and even board temperature. Other factors are: trace width, total printed circuit copper area, copper thickness, single or double-sided, multi-layer board and the amount of solder on the board.

The effectiveness of the PC board to dissipate heat also depends on the size, quantity and spacing of other components on the board, as well as whether the surrounding air is still or moving. Furthermore, some of these components such as the catch diode will add heat to the PC board and the heat can vary as the input voltage changes. For the inductor, depending on the physical size, type of core material and the DC resistance, it could either act as a heat sink taking heat away from the board, or it could add heat to the board.



Typical Characteristics

Output Ripple

($V_{IN}=12V, V_{OUT}=3.3V, I_{OUT}=2A$)

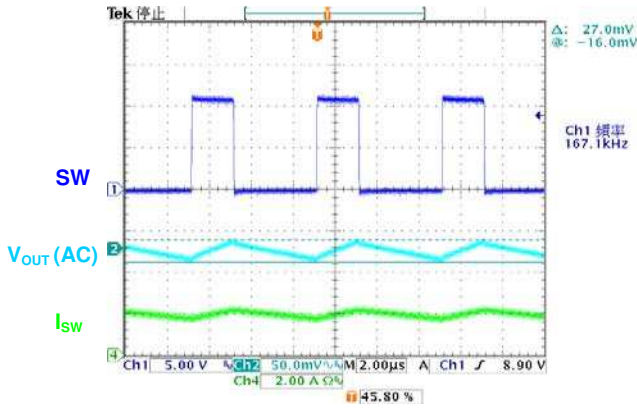

Power on test wave

($V_{IN}=12V, V_{OUT}=5V, I_{OUT}=2A$)

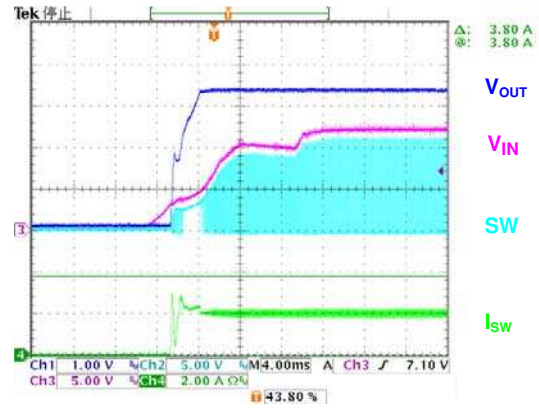

Load Transient Response

($V_{IN}=12V, V_{OUT}=3.3V, I_{OUT}=0.1\sim 2A$)

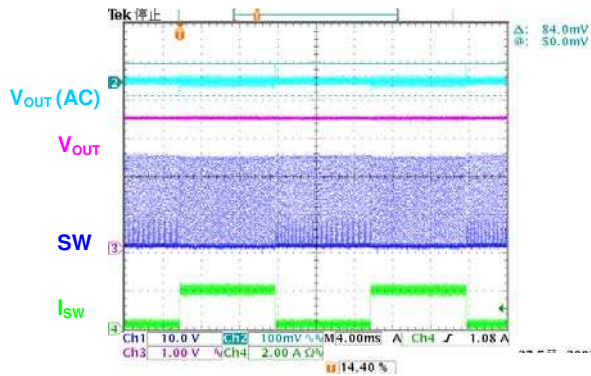

EN on test wave

($V_{IN}=12V, V_{OUT}=5V, I_{OUT}=2A$)

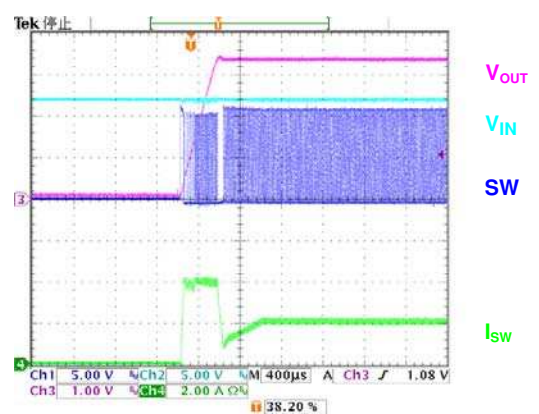

Efficiency

($V_{IN}=12V, V_{OUT}=3.3V$)

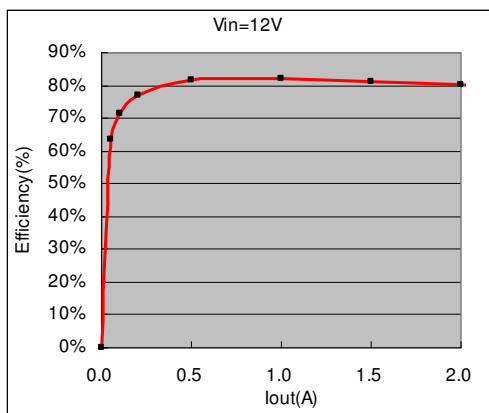

Efficiency

($V_{IN}=12V, V_{OUT}=5.0V$)

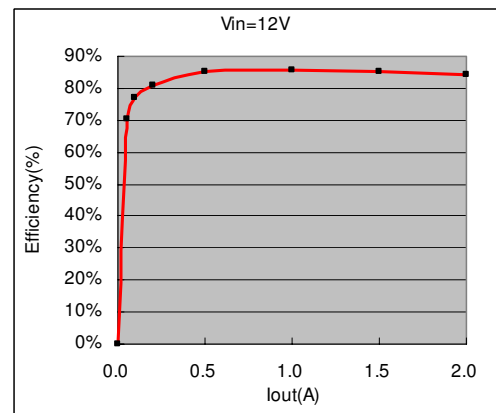



Package Dimensions: SO-8

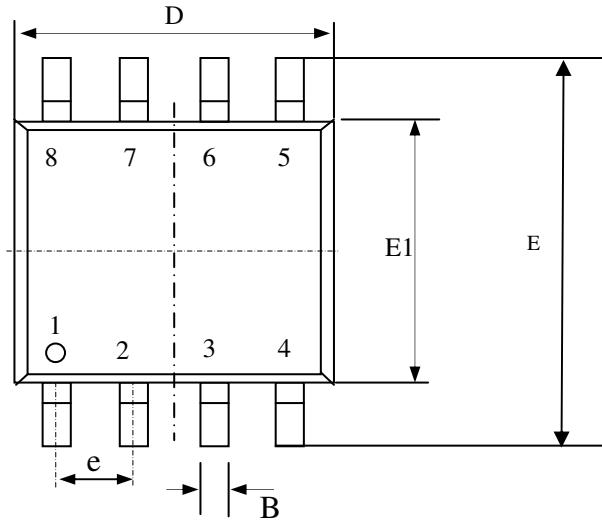

SYMBOLS	Millimeters		
	MIN	NOM	MAX
A	1.35	1.55	1.75
A1	0.10	0.18	0.25
B	0.33	0.41	0.51
C	0.19	0.22	0.25
D	4.80	4.90	5.00
E1	3.80	3.90	4.00
E	5.80	6.15	6.50
L	0.38	0.71	1.27
θ	0	4.00	8.00
e	1.27 TYP		

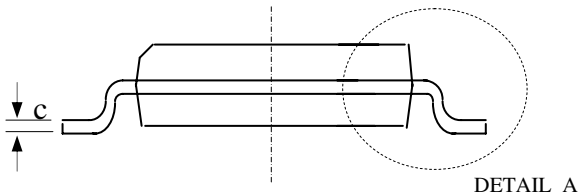
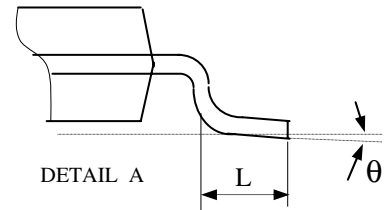
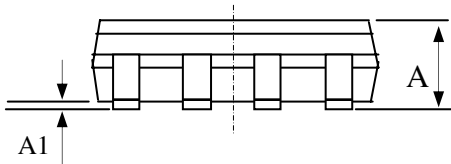

1. All dimensions are in millimeters.
2. Dimensions do not include mold protrusions.

Marking Information:

