



1A Low Dropout Positive Voltage Regulators

Features

- Maximum dropout of 1.5V at full load current
- Fast transient response
- Output current limiting
- Built-in thermal shutdown
- Available packages: SOT223, TO252, SOT89
- Good noise rejection
- Stable with Only 1uF Low ESR Ceramic Capacitor
- Three-terminal adjustable or fixed 1.5V, 1.8V, 1.9V, 2.5V, 3.3V, 5.0V
- RoHS-compliant, halogen-free

Description

The APE1117A is a low dropout positive adjustable or fixed-mode regulator with minimum output current capability of 1A. The product is specifically designed to provide well-regulated supply for low-voltage IC applications such as high-speed bus-termination and low current 3.3V logic supplies. It is also well suited for other applications such as VGA cards. The APE1117A is guaranteed to have lower than 1.5V dropout at full load current making it ideal to provide well-regulated outputs of 1.25 to 5.0V with 6.4V to 16V input supply.

Typical Applications

- PC peripherals
- Communications

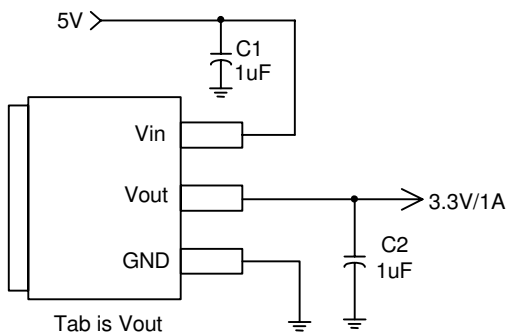

5V/3.3V using fixed output version

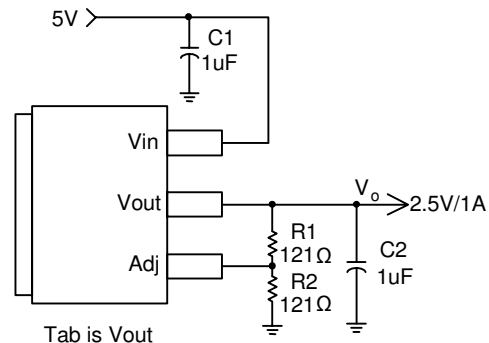

5V/2.5V using adjustable output version

Note: $V_o = V_{REF} * (1 + \frac{R_2}{R_1})$

Ordering information

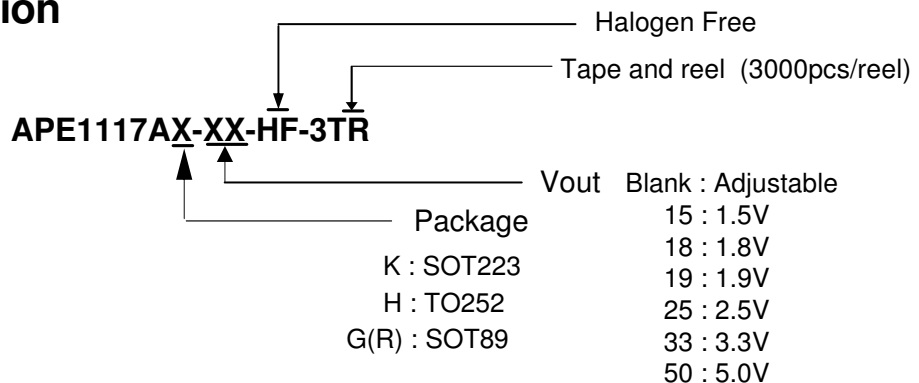

Example: APE1117AK-33-HF-3TR 3.3V fixed output in RoHS-compliant, halogen free SOT-223 shipped on tape and reel, 3000pcs/reel



Block Diagram

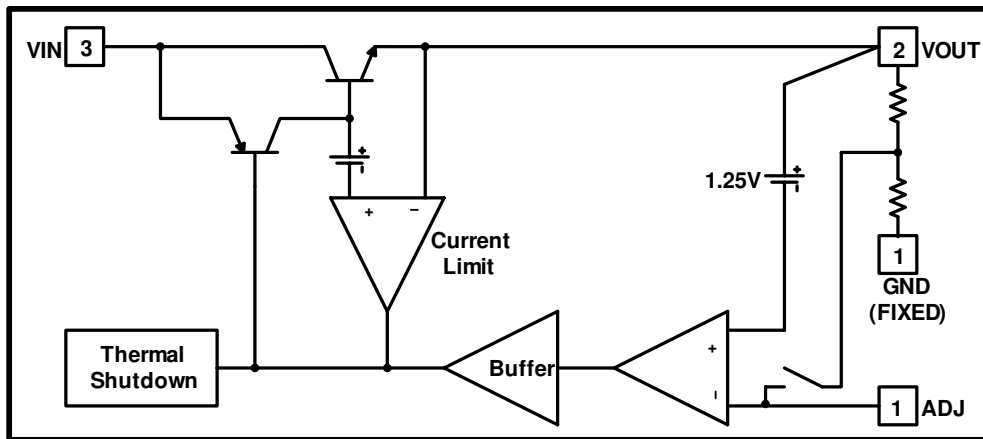

Pin Configurations

3 PIN SOT223

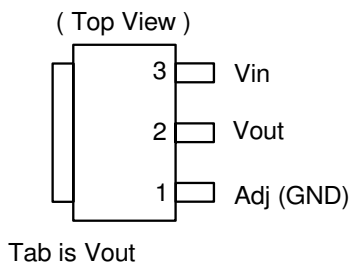

3 PIN TO252

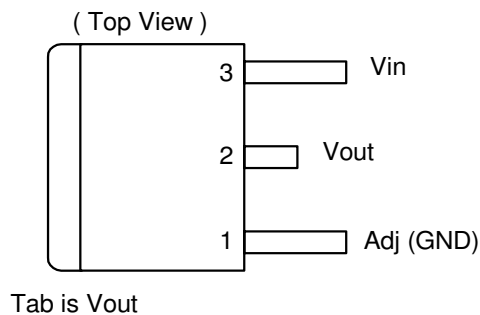

3 PIN SOT89

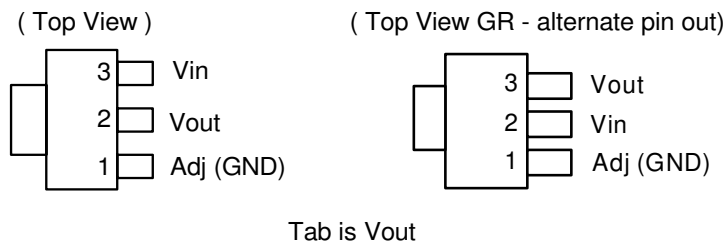

THIS PRODUCT IS SENSITIVE TO ELECTROSTATIC DISCHARGE, PLEASE HANDLE WITH CAUTION.
 USE OF THIS PRODUCT AS A CRITICAL COMPONENT IN LIFE SUPPORT OR OTHER SIMILAR SYSTEMS IS NOT AUTHORIZED.
 APEC DOES NOT ASSUME ANY LIABILITY ARISING OUT OF THE APPLICATION OR USE OF ANY PRODUCT OR CIRCUIT DESCRIBED
 HEREIN; NEITHER DOES IT CONVEY ANY LICENSE UNDER ITS PATENT RIGHTS, NOR THE RIGHTS OF OTHERS.
 APEC RESERVES THE RIGHT TO MAKE CHANGES WITHOUT FURTHER NOTICE TO ANY PRODUCTS HEREIN TO IMPROVE
 RELIABILITY, FUNCTION OR DESIGN.



Pin Descriptions

NAME	I/O	PIN #	FUNCTION
Adj (GND)	I	1	A resistor divider from this pin to the Vout pin and ground sets the adjustable output voltage. (Ground this pin only for Fixed-Mode)
Vout	O	2	The output of the regulator. A capacitor with a minimum value of $1\mu\text{F}$ ($0.01\Omega \leq \text{ESR} \leq 1\Omega$) must be connected from this pin to ground to ensure stability.
Vin	I	3	The input pin of regulator. A capacitor with a minimum value of $1\mu\text{F}$ is connected from this pin to ground to ensure that the input voltage does not sag below the minimum dropout voltage during the load transient response. This pin must always be 1.5V higher than Vout in order for the device to regulate properly.

Absolute Maximum Ratings

Symbol	Parameter	Rating	Unit	
Vin	DC Supply Voltage	-0.3 to 16	V	
PD	Power Dissipation	SOT-223	850	mW
		SOT-89	330	mW
		TO-252	1050	mW
T _{ST}	Storage Temperature	-65 to +150	°C	
T _{OP}	Operating Junction Temperature Range	0 to +150	°C	



Electrical Characteristics

PARAMETER	CONDITIONS		MIN	TYP	MAX	UNIT
Reference Voltage	APE1117A-ADJ	$T_J=25^{\circ}\text{C}$, $(V_{IN}-V_{OUT})=1.5\text{V}$ $I_O=10\text{mA}$	1.225	1.250	1.275	V
Output Voltage	APE1117A-15	$I_{OUT} = 10\text{mA}$, $T_J = 25^{\circ}\text{C}$, $3\text{V} < V_{IN} < 16\text{V}$	1.470	1.500	1.530	V
	APE1117A-18	$I_{OUT} = 10\text{mA}$, $T_J = 25^{\circ}\text{C}$, $3.3\text{V} < V_{IN} < 16\text{V}$	1.764	1.800	1.836	V
	APE1117A-19	$I_{OUT} = 10\text{mA}$, $T_J = 25^{\circ}\text{C}$, $3.3\text{V} < V_{IN} < 16\text{V}$	1.862	1.900	1.938	V
	APE1117A-25	$I_{OUT} = 10\text{mA}$, $T_J = 25^{\circ}\text{C}$, $4\text{V} < V_{IN} < 16\text{V}$	2.450	2.500	2.550	V
	APE1117A-33	$I_{OUT} = 10\text{mA}$, $T_J = 25^{\circ}\text{C}$, $4.8\text{V} < V_{IN} < 16\text{V}$	3.235	3.300	3.365	V
	APE1117A-50	$I_{OUT} = 10\text{mA}$, $T_J = 25^{\circ}\text{C}$, $6.5\text{V} < V_{IN} < 16\text{V}$	4.900	5.000	5.100	V
Line Regulation	APE1117A-XXX	$I_O=10\text{mA}$, $V_{OUT}+1.5\text{V}<V_{IN}<16\text{V}$, $T_J=25^{\circ}\text{C}$			0.5	%
Load Regulation	APE1117A-ADJ	$V_{IN}=3.3\text{V}$, $V_{adj}=0$, $10\text{mA}<I_O<1\text{A}$, $T_J=25^{\circ}\text{C}$ (Note 1,2)			1	%
	APE1117A-15	$V_{IN}=3\text{V}$, $10\text{mA}<I_O<1\text{A}$, $T_J=25^{\circ}\text{C}$ (Note 1,2)		12	15	mV
	APE1117A-18	$V_{IN}=3.3\text{V}$, $10\text{mA}<I_O<1\text{A}$, $T_J=25^{\circ}\text{C}$ (Note 1,2)		15	18	mV
	APE1117A-19	$V_{IN}=3.3\text{V}$, $10\text{mA}<I_O<1\text{A}$, $T_J=25^{\circ}\text{C}$ (Note 1,2)		16	19	mV
	APE1117A-25	$V_{IN}=4\text{V}$, $10\text{mA}<I_O<1\text{A}$, $T_J=25^{\circ}\text{C}$ (Note 1,2)		20	25	mV
	APE1117A-33	$V_{IN} = 5\text{V}$, $10\text{mA}<I_O<1\text{A}$, $T_J=25^{\circ}\text{C}$ (Note 1,2)		26	33	mV
	APE1117A-50	$V_{IN} = 6.5\text{V}$, $10\text{mA}<I_O<1\text{A}$, $T_J=25^{\circ}\text{C}$ (Note 1,2)		40	50	mV
Dropout Voltage ($V_{IN}-V_{OUT}$)	APE1117A-XXX	$I_{OUT} = 1\text{A}$, $\Delta V_{OUT} = 1\%V_{OUT}$		1.3	1.5	V
Current Limit	APE1117A-XXX	$(V_{IN}-V_{OUT}) = 5\text{V}$	1.1			A
Minimum Load Current	APE1117A-XXX	$0^{\circ}\text{C} < T_J < 125^{\circ}\text{C}$		5	10	mA
Thermal Regulation	$T_A=25^{\circ}\text{C}$, 30ms pulse			0.008	0.04	%/W
Ripple Rejection	$f=120\text{Hz}$, $C_{OUT}=25\mu\text{F}$ Tantalum, $I_{OUT}=1\text{A}$					
	APE1117A-XXX	$V_{IN}=V_{OUT}+3\text{V}$		60	70	dB
Temperature Stability	$I_O=10\text{mA}$			0.5		%
Thermal Shutdown Temperature				150		$^{\circ}\text{C}$
Thermal Shutdown Temperature Recovery				130		$^{\circ}\text{C}$
θ_{JA} Thermal Resistance Junction-to-Ambient (No heat sink; no air flow)	SOT89			300		$^{\circ}\text{C}/\text{W}$
	SOT-223			117		
	TO-252			92		
θ_{JC} Thermal Resistance Junction-to-Case	SOT89 : Control Circuitry/Power Transistor			100		$^{\circ}\text{C}/\text{W}$
	SOT-223 : Control Circuitry/Power Transistor			15		
	TO-252 : Control Circuitry/Power Transistor			10		
I_Q Quiescent Current	APE1117A-18/25/28	$V_{IN} < 9\text{V}$		5.5	10	mA
	APE1117A-33	$V_{IN} < 12\text{V}$		5.5	10	

Note1: See thermal regulation specifications for changes in output voltage due to heating effects. Line and load regulation are measured at a constant junction temperature by low duty cycle pulse testing. Load regulation is measured at the output lead = 1/18" from the package.

Note2: Line and load regulation are guaranteed up to the maximum power dissipation of 15W. Power dissipation is determined by the difference between input and output differential and the output current. Guaranteed maximum power dissipation will not be available over the full input/output range.

Note3: Quiescent current is defined as the minimum output current required in maintaining regulation. At 12V input/output differential the device is guaranteed to regulate if the output current is greater than 10mA.



Electrical Characteristics (cont.)

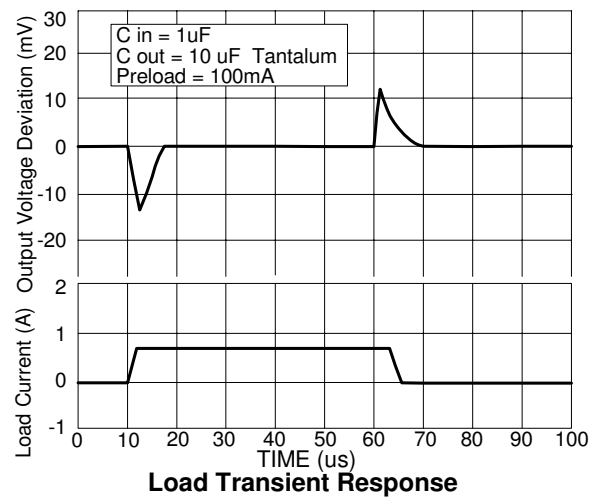
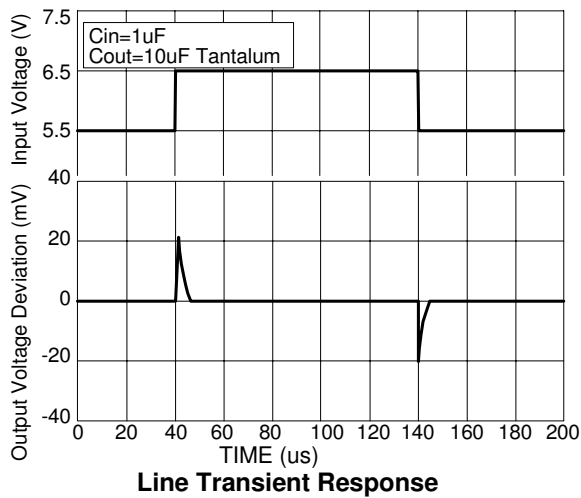
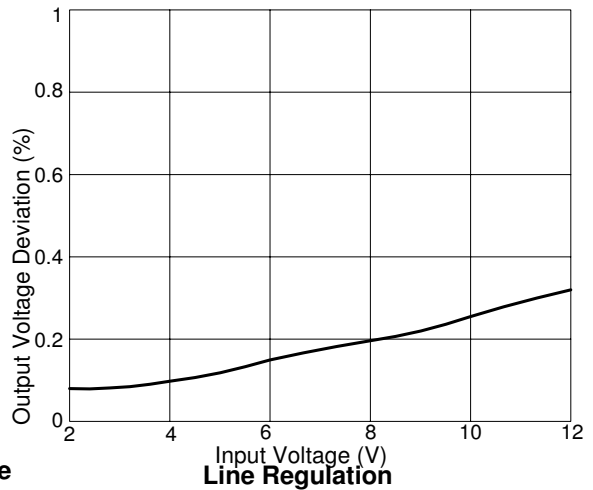
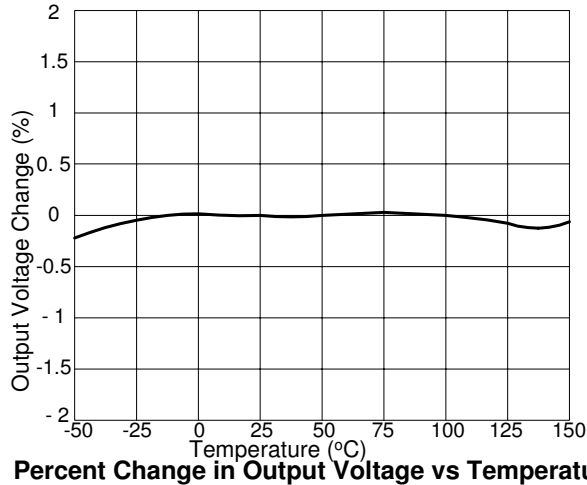
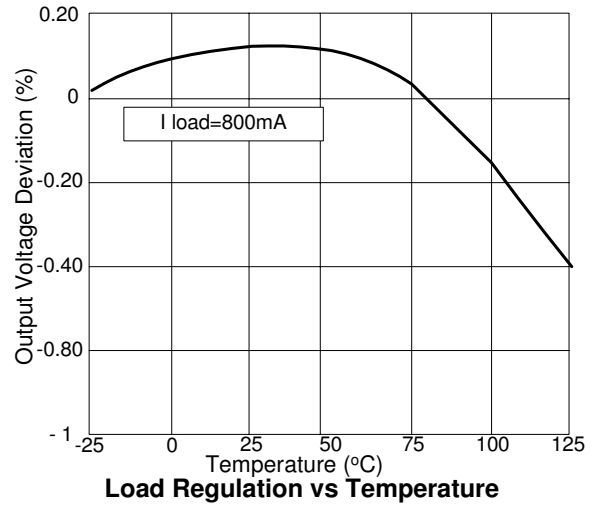
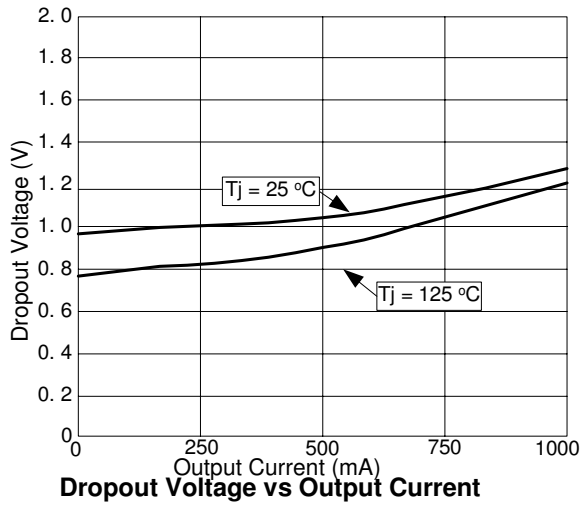



Marking Information

SOT-223

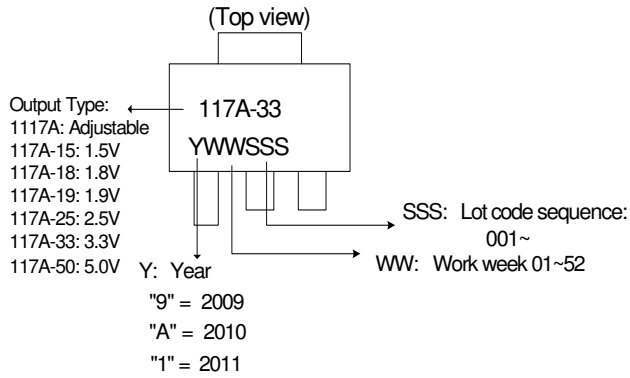

TO-252

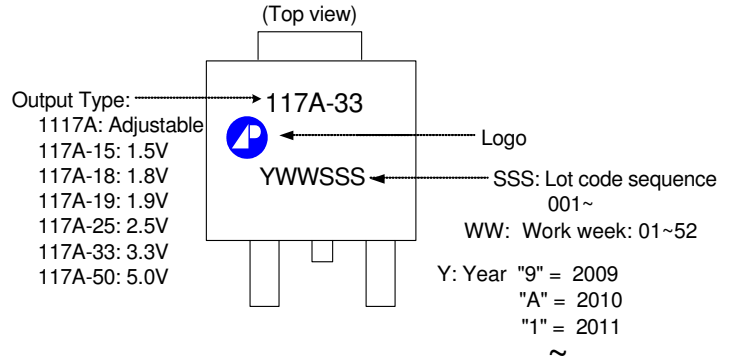

SOT-89

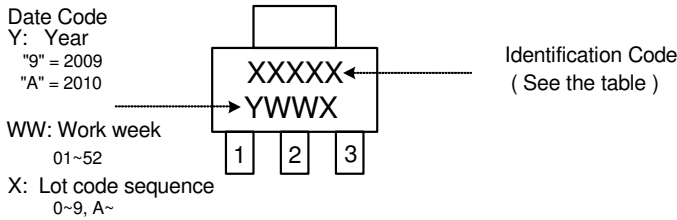

Identification code	Output Type
17AA(R)	Adjustable (R)
17AB(R)	1.5V (R)
17AC(R)	1.8V (R)
17AG(R)	1.9V (R)
17AD(R)	2.5V (R)
17AE(R)	3.3V (R)
17AF(R)	5.0V (R)



Package Dimensions: TO-252

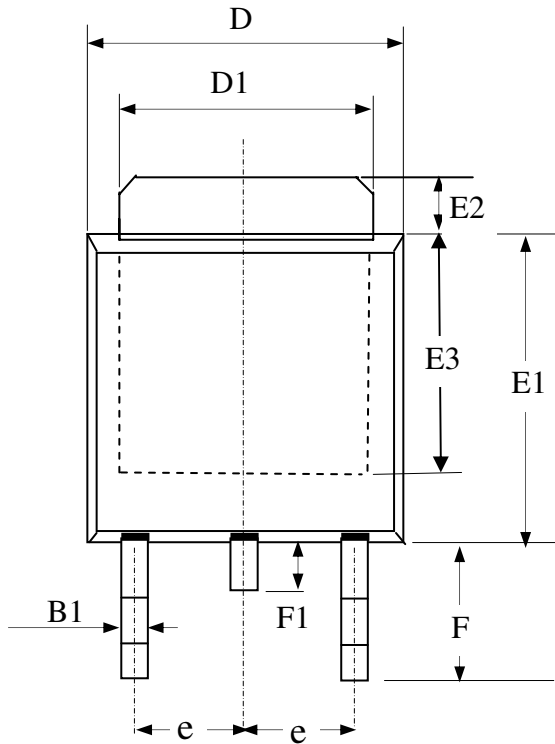

SYMBOLS	Millimeters		
	MIN	NOM	MAX
A2	1.80	2.30	2.80
A3	0.40	0.50	0.60
B1	0.40	0.70	1.00
D	6.00	6.50	7.00
D1	4.80	5.35	5.90
E3	3.50	4.00	4.50
F	2.20	2.63	3.05
F1	0.50	0.85	1.20
E1	5.10	5.70	6.30
E2	0.50	1.10	1.80
e	--	2.30	--
C	0.35	0.50	0.65

1. All dimensions are in millimeters.
2. Dimensions do not include mold protrusions.

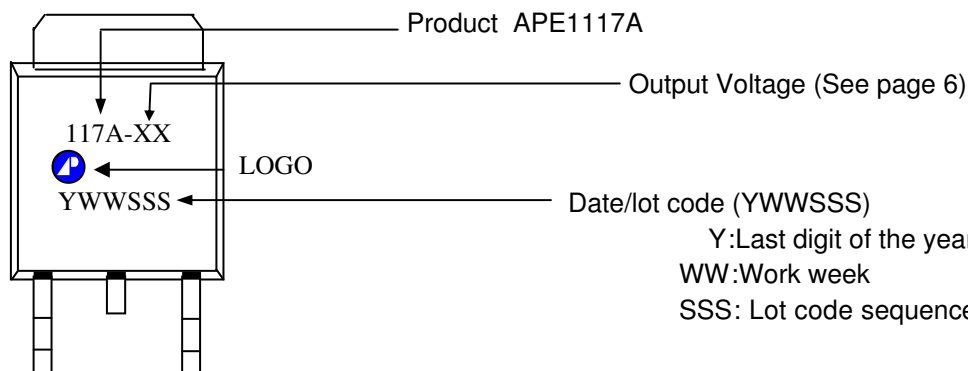
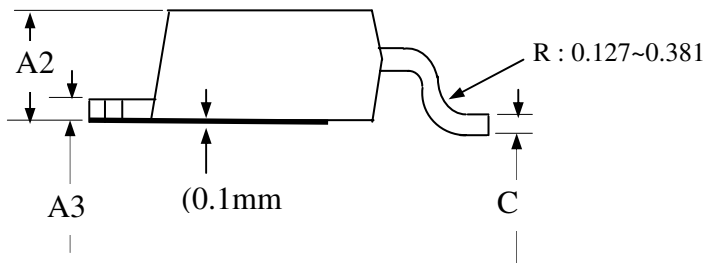



Package Dimensions: SOT-223

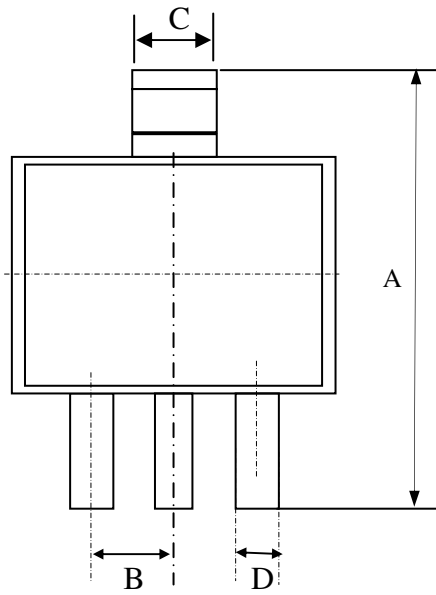

SYMBOLS	Millimeters		
	MIN	NOM	MAX
A	6.70	7.00	7.30
B	---	2.30	---
C	2.90	3.00	3.10
D	0.60	0.70	0.80
G	0.25	0.30	0.35
E	6.30	6.50	6.70
F	1.40	1.60	1.80
K	0.02	0.06	0.10

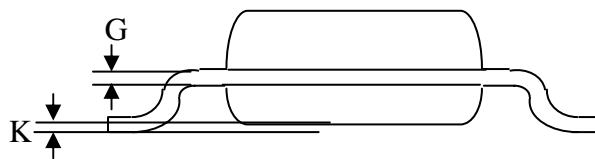
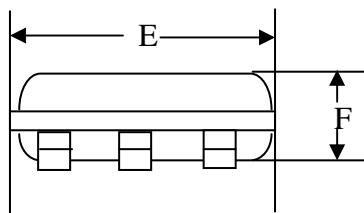

1. All dimensions are in millimeters.
2. Dimensions do not include mold protrusions.

Marking Information

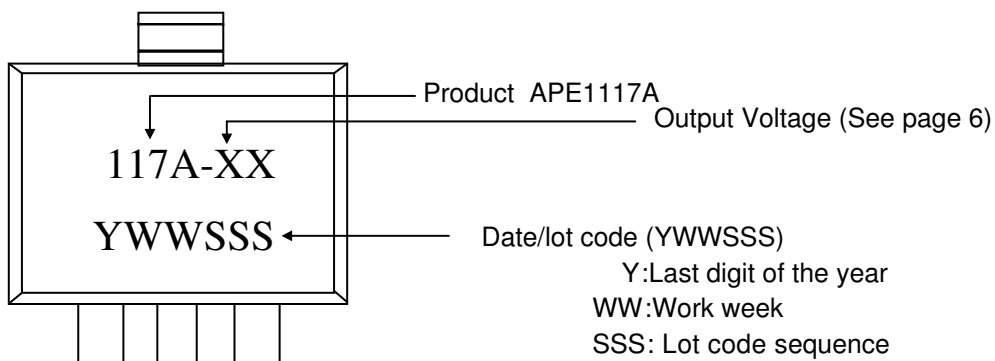



Package Dimensions: SOT-89

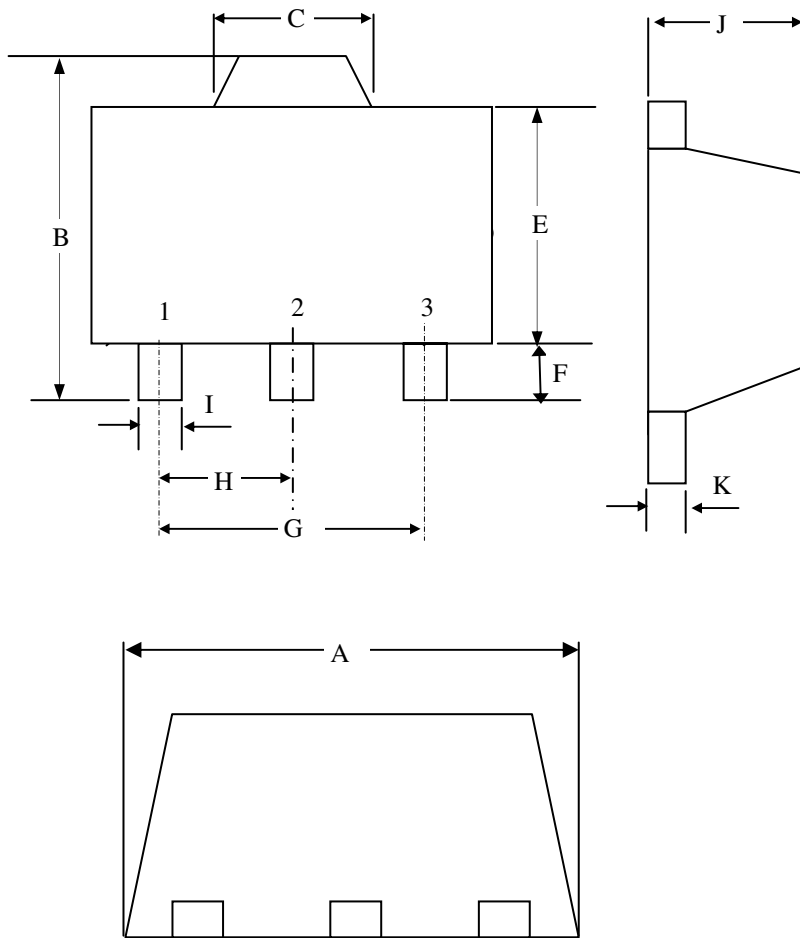

SYMBOLS	Millimeters		
	MIN	NOM	MAX
A	4.40	-	4.60
B	4.05	-	4.25
C	1.40	-	1.75
E	2.40	-	2.60
F	0.89	-	1.20
I	0.35	-	0.55
H	----	1.50	----
G	----	3.00	----
J	1.40	-	1.60
K	0.35	-	0.43

1. All dimensions are in millimeters.
2. Dimensions do not include mold protrusions.

Marking Information

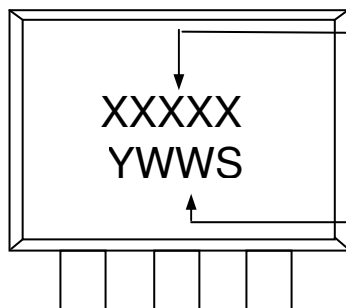

Product: See table on page 6

Date/lot code (YWWS)

Y: Last digit of the year

WW: Work week

S: Lot code sequence