



**N-channel Enhancement-mode Power MOSFET**

- Simple Drive Requirement**
- Low On-resistance**
- Fast Switching Performance**
- RoHS-compliant, halogen-free**



$BV_{DSS}$	75V
$R_{DS(ON)}$	11mΩ
$I_D$	80A

**Description**

Advanced Power MOSFETs from APEC provide the designer with the best combination of fast switching, low on-resistance and cost-effectiveness.

The AP75N07GS-HF-3 is in the TO-263 package, which is widely used for commercial and industrial surface-mount applications, and is well suited for low voltage applications such as DC/DC converters.

The AP75N07GP-HF-3 is in the TO-220 through-hole package which is used where a low PCB footprint or an attached heatsink is required.

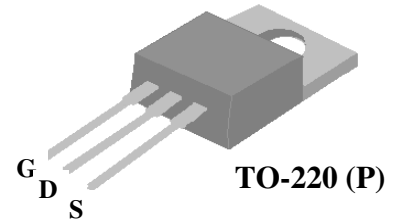
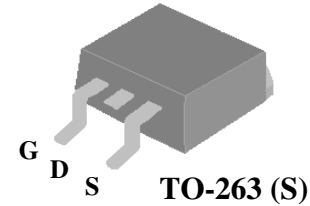

**Absolute Maximum Ratings**

Symbol	Parameter	Rating	Units
$V_{DS}$	Drain-Source Voltage	75	V
$V_{GS}$	Gate-Source Voltage	±20	V
$I_D$ at $T_C=25\text{ }^\circ\text{C}$	Continuous Drain Current <sup>3</sup>	80	A
$I_D$ at $T_C=100\text{ }^\circ\text{C}$	Continuous Drain Current <sup>3</sup>	70	A
$I_{DM}$	Pulsed Drain Current <sup>1</sup>	320	A
$P_D$ at $T_C=25\text{ }^\circ\text{C}$	Total Power Dissipation	300	W
	Linear Derating Factor	2	W/°C
$E_{AS}$	Single Pulse Avalanche Energy <sup>3</sup>	450	mJ
$T_{STG}$	Storage Temperature Range	-55 to 175	°C
$T_J$	Operating Junction Temperature Range	-55 to 175	°C

**Thermal Data**

Symbol	Parameter	Value	Unit
Rthj-c	Maximum Thermal Resistance, Junction-case	0.9	°C/W
Rthj-a	Maximum Thermal Resistance, Junction-ambient (PCB mount)	40	°C/W
Rthj-a	Maximum Thermal Resistance, Junction-ambient	62	°C/W

**Ordering Information**

**AP75N07GS-HF-3TR**    **RoHS-compliant halogen-free TO-263, shipped on tape and reel (800 pcs/reel)**

**AP75N07GP-HF-3TB**    **RoHS-compliant halogen-free TO-220, shipped in tubes**



**Electrical Specifications at  $T_j=25^\circ\text{C}$  (unless otherwise specified)**

Symbol	Parameter	Test Conditions	Min.	Typ.	Max.	Units
$BV_{DSS}$	Drain-Source Breakdown Voltage	$V_{GS}=0V, I_D=1\text{mA}$	75	-	-	V
$\Delta BV_{DSS}/\Delta T_j$	Breakdown Voltage Temperature Coefficient	Reference to $25^\circ\text{C}, I_D=1\text{mA}$	-	0.08	-	$V/^\circ\text{C}$
$R_{DS(ON)}$	Static Drain-Source On-Resistance <sup>2</sup>	$V_{GS}=10V, I_D=40A$	-	-	11	m $\Omega$
$V_{GS(th)}$	Gate Threshold Voltage	$V_{DS}=V_{GS}, I_D=250\mu A$	1	-	3	V
$g_{fs}$	Forward Transconductance	$V_{DS}=15V, I_D=40A$	-	120	-	S
$I_{DSS}$	Drain-Source Leakage Current	$V_{DS}=75V, V_{GS}=0V$	-	-	1	$\mu A$
	Drain-Source Leakage Current ( $T_j=125^\circ\text{C}$ )	$V_{DS}=60V, V_{GS}=0V$	-	-	250	$\mu A$
$I_{GSS}$	Gate-Source Leakage	$V_{GS}=\pm 20V, V_{DS}=0V$	-	-	$\pm 100$	nA
$Q_g$	Total Gate Charge <sup>2</sup>	$I_D=40A$	-	83	130	nC
$Q_{gs}$	Gate-Source Charge	$V_{DS}=60V$	-	10	-	nC
$Q_{gd}$	Gate-Drain ("Miller") Charge	$V_{GS}=4.5V$	-	51	-	nC
$t_{d(on)}$	Turn-on Delay Time <sup>2</sup>	$V_{DD}=40V$	-	15	-	ns
$t_r$	Rise Time	$I_D=30A$	-	73	-	ns
$t_{d(off)}$	Turn-off Delay Time	$R_G=10\Omega, V_{GS}=10V$	-	340	-	ns
$t_f$	Fall Time	$R_D=1.33\Omega$	-	200	-	ns
$C_{iss}$	Input Capacitance	$V_{GS}=0V$	-	4270	6830	pF
$C_{oss}$	Output Capacitance	$V_{DS}=25V$	-	690	-	pF
$C_{riss}$	Reverse Transfer Capacitance	$f=1.0\text{MHz}$	-	320	-	pF
$R_g$	Gate Resistance	$f=1.0\text{MHz}$	-	1.8	2.7	$\Omega$

**Source-Drain Diode**

Symbol	Parameter	Test Conditions	Min.	Typ.	Max.	Units
$V_{SD}$	Forward On Voltage <sup>2</sup>	$T_j=25^\circ\text{C}, I_S=40A, V_{GS}=0V$	-	-	1.5	V
$t_{rr}$	Reverse Recovery Time	$I_S=40A, V_{GS}=0V$	-	90	-	ns
$Q_{rr}$	Reverse Recovery Charge	$di/dt=100A/\mu s$	-	235	-	nC

**Notes:**

1. Pulse width limited by maximum junction temperature.
2. Pulse test
3. Starting  $T_j=25^\circ\text{C}$ ,  $V_{DD}=50V$ ,  $L=1\text{mH}$ ,  $R_G=25\Omega$ ,  $I_{AS}=30A$ .
4. Package limitation current is 80A.
5. Surface-mounted on 1 in<sup>2</sup> copper pad of FR4 board

THIS PRODUCT IS SENSITIVE TO ELECTROSTATIC DISCHARGE, PLEASE HANDLE WITH CAUTION.

USE OF THIS PRODUCT AS A CRITICAL COMPONENT IN LIFE SUPPORT OR OTHER SIMILAR SYSTEMS IS NOT AUTHORIZED.

APEC DOES NOT ASSUME ANY LIABILITY ARISING OUT OF THE APPLICATION OR USE OF ANY PRODUCT OR CIRCUIT DESCRIBED HEREIN; NEITHER DOES IT CONVEY ANY LICENSE UNDER ITS PATENT RIGHTS, NOR THE RIGHTS OF OTHERS.

APEC RESERVES THE RIGHT TO MAKE CHANGES WITHOUT FURTHER NOTICE TO ANY PRODUCTS HEREIN TO IMPROVE RELIABILITY, FUNCTION OR DESIGN.



Typical Electrical Characteristics

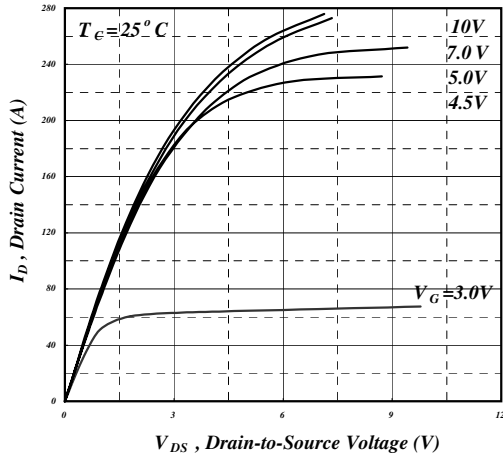

Fig 1. Typical Output Characteristics

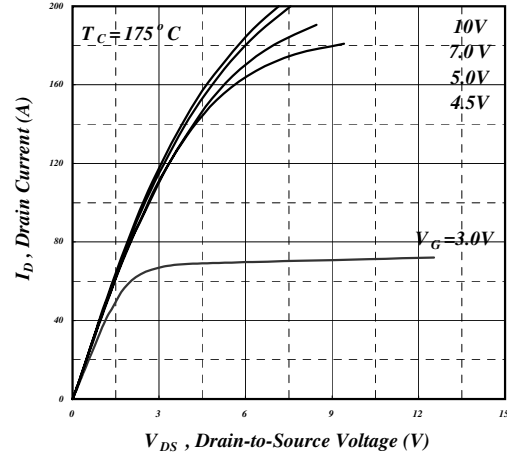

Fig 2. Typical Output Characteristics

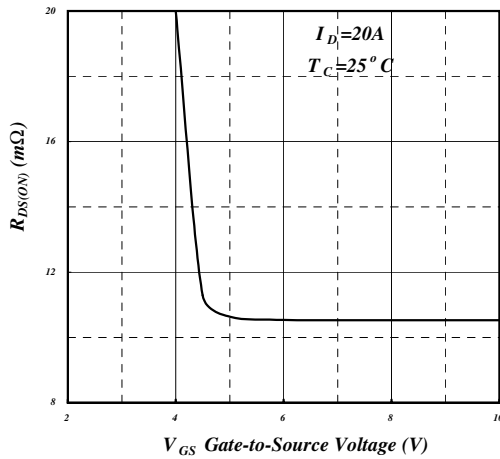

Fig 3. On-Resistance vs. Gate Voltage

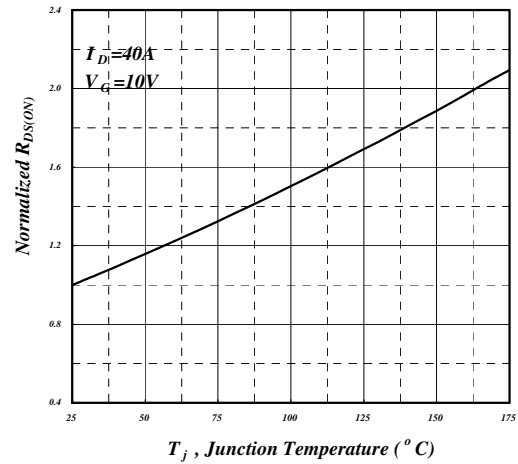

Fig 4. Normalized On-Resistance vs. Junction Temperature

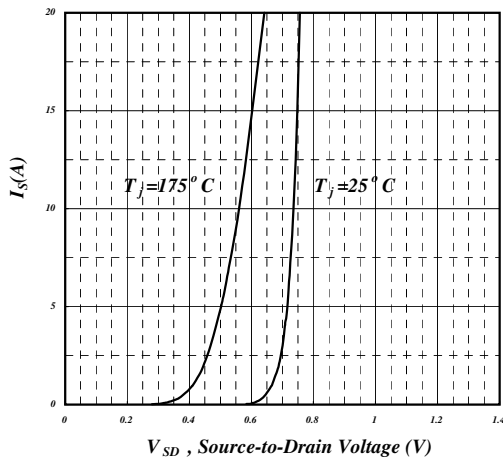

Fig 5. Forward Characteristic of Reverse Diode

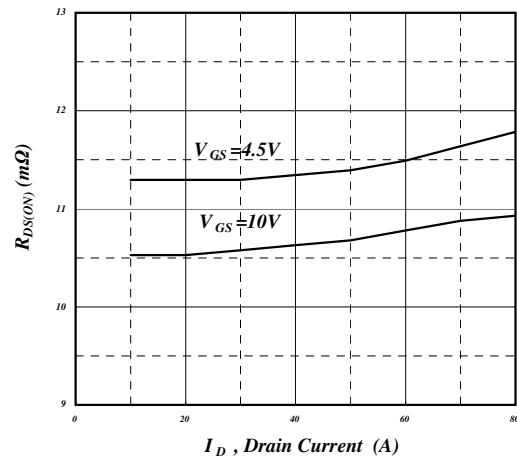

Fig 6. On-Resistance vs. Drain Current



Typical Electrical Characteristics (cont.)

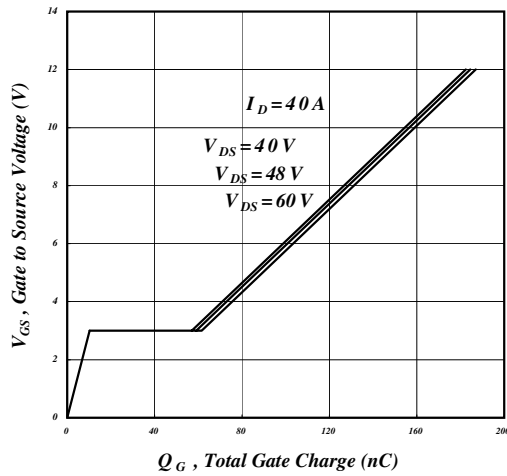

Fig 7. Gate Charge Characteristics

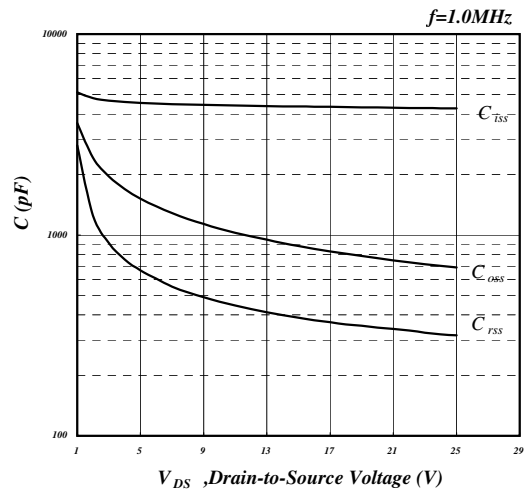

Fig 8. Typical Capacitance Characteristics

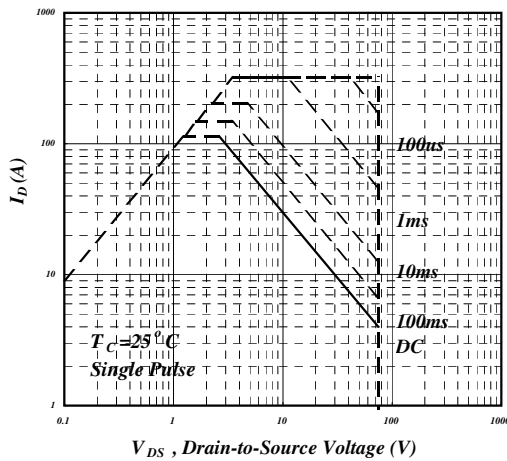

Fig 9. Maximum Safe Operating Area

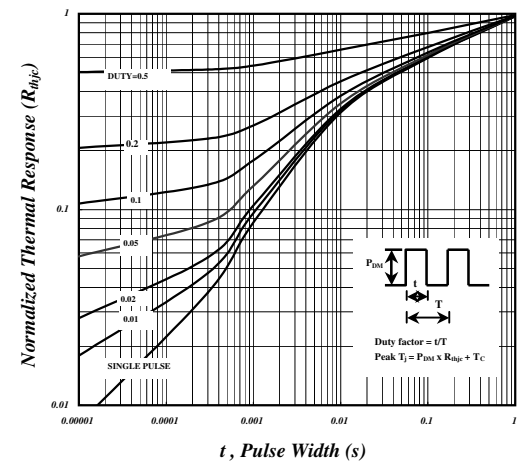

Fig 10. Effective Transient Thermal Impedance

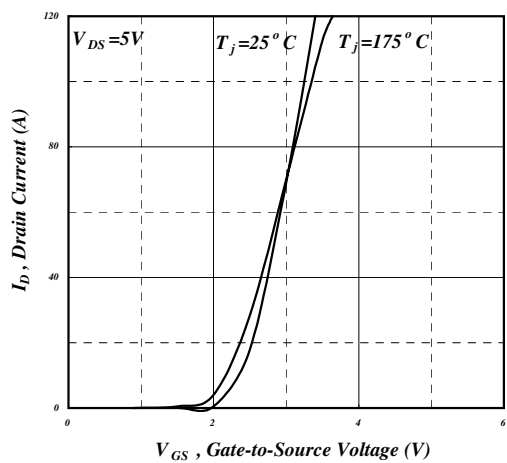

Fig 11. Transfer Characteristics

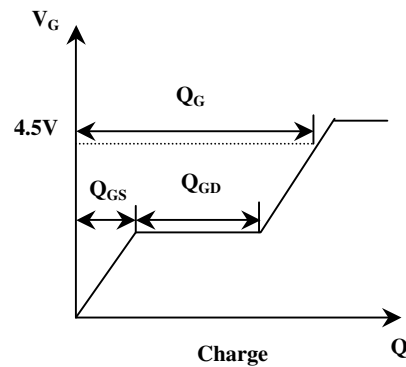
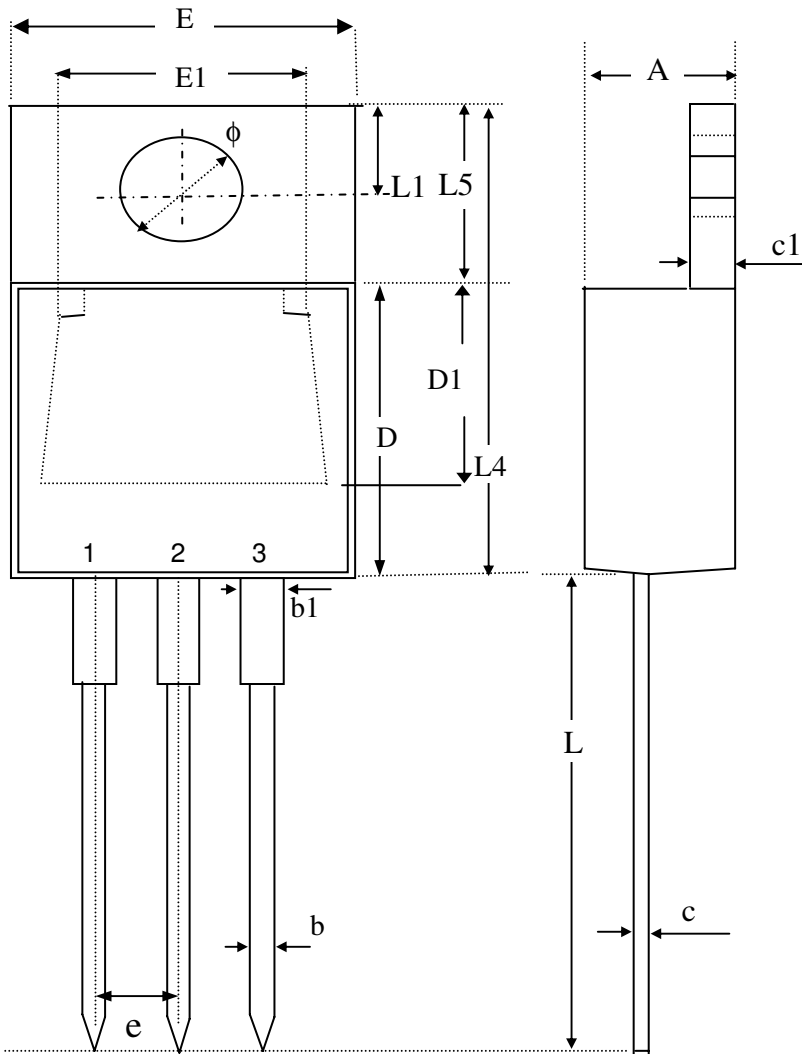

Fig 12. Gate Charge Waveform



**Package Dimensions: TO-220**



SYMBOLS	Millimeters		
	MIN	NOM	MAX
A	4.40	4.60	4.80
b	0.76	0.88	1.00
D	8.60	8.80	9.00
c	0.36	0.43	0.50
E	9.80	10.10	10.40
L4	14.70	15.00	15.30
L5	6.20	6.40	6.60
D1	5.10 REF.		
c1	1.25	1.35	1.45
b1	1.17	1.32	1.47
L	13.25	13.75	14.25
e	2.54 REF.		
L1	2.60	2.75	2.89
phi	3.71	3.84	3.96
E1	7.4 REF.		

1. All dimensions are in millimeters.
2. Dimensions do not include mold protrusions.

**Marking Information: TO-220**

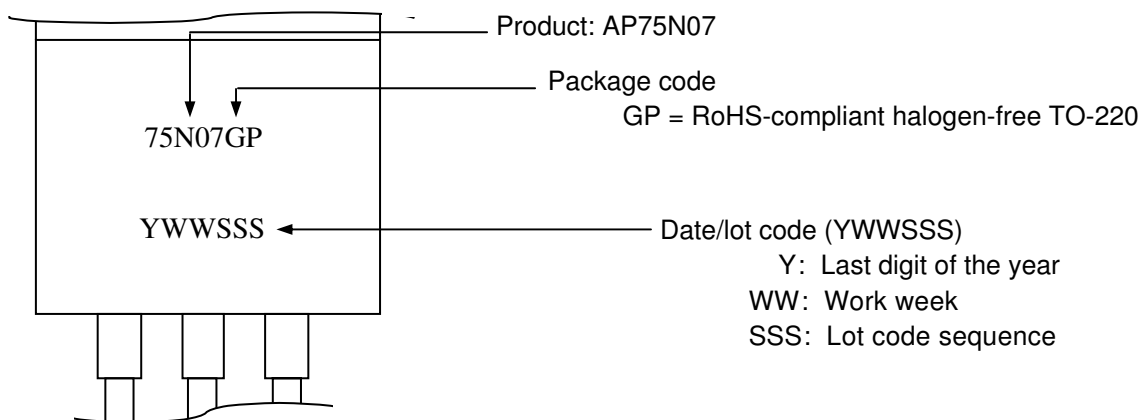



**Package Dimensions: TO-263**

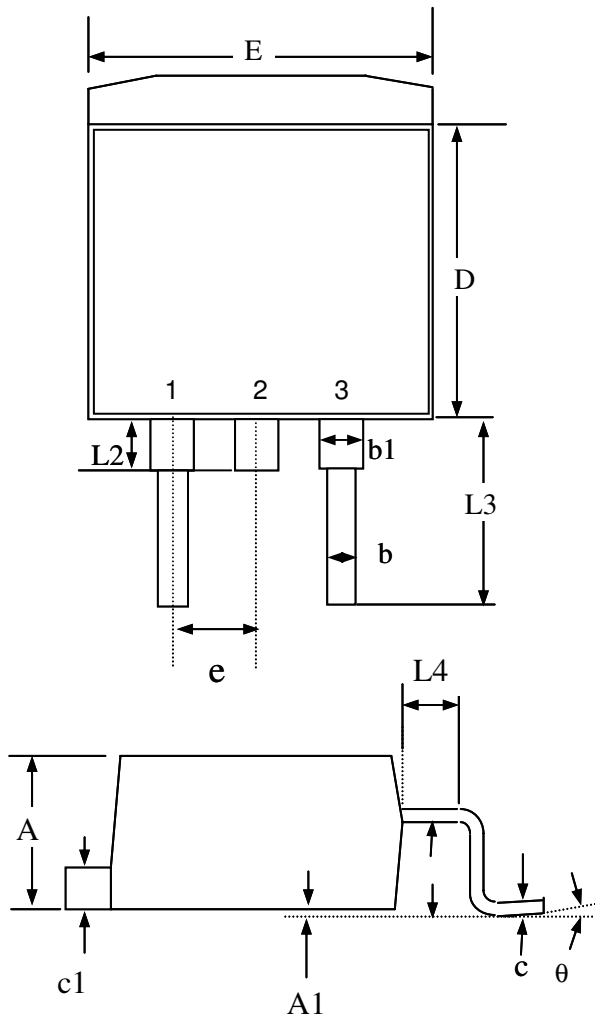

SYMBOLS	Millimeters		
	MIN	NOM	MAX
A	4.25	4.75	5.20
A1	0.00	0.15	0.30
A2	2.20	2.45	2.70
b	0.70	0.90	1.10
b1	1.07	1.27	1.47
c	0.30	0.45	0.60
c1	1.15	1.30	1.45
D	8.30	8.90	9.40
E	9.70	10.10	10.50
e	2.04	2.54	3.04
L2	-----	1.50	-----
L3	4.50	4.90	5.30
L4	-----	1.50	----

1. All dimensions are in millimeters.
2. Dimensions do not include mold protrusions.

**Marking Information: TO-263**

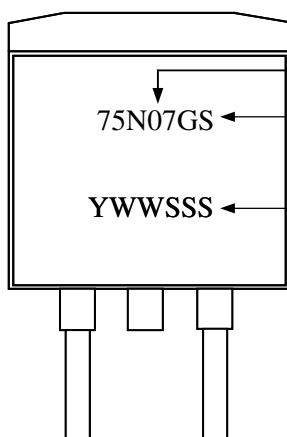

Product: AP75N07  
 Package code:  
 GS = RoHS-compliant halogen-free TO-263  
 Date Code (YWWSSS)  
 Y : Last digit of the year  
 WW : Work week  
 SSS : Lot code sequence