

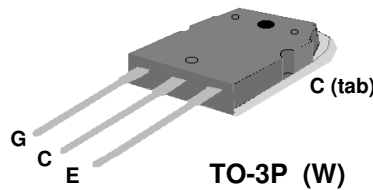

N-Channel Insulated Gate Bipolar Power Transistor

High Speed Switching
Low Saturation Voltage
 Typical $V_{CE(sat)} = 1.8V$ at $I_C=20A$
RoHS-compliant, halogen-free



V_{CES}	600V
I_C	20A

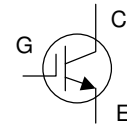

Absolute Maximum Ratings

Symbol	Parameter	Rating	Units
V_{CES}	Collector-Emitter Voltage	600	V
V_{GE}	Gate-Emitter Voltage	± 20	V
I_C at $T_C=25^\circ C$	Collector Current	40	A
I_C at $T_C=100^\circ C$	Collector Current	20	A
I_{CM}	Pulsed Collector Current ¹	160	A
P_D at $T_C=25^\circ C$	Maximum Power Dissipation	125	W
T_{STG}	Storage Temperature Range	-55 to 150	$^\circ C$
T_J	Operating Junction Temperature Range	150	$^\circ C$

Notes:

1. Pulse width limited by maximum junction temperature.

Thermal Data

Symbol	Parameter	Value	Units
Rthj-c	Thermal Resistance, Junction-Case	1.0	$^\circ C/W$
Rthj-a	Thermal Resistance, Junction-Ambient	40	$^\circ C/W$

Electrical Specifications at $T_J=25^\circ C$ (unless otherwise specified)

Symbol	Parameter	Test Conditions	Min.	Typ.	Max.	Units
I_{GES}	Gate-to-Emitter Leakage Current	$V_{GE}=\pm 20V, V_{CE}=0V$	-	-	± 100	nA
I_{CES}	Collector-Emitter Leakage Current	$V_{CE}=600V, V_{GE}=0V$	-	-	25	μA
$V_{CE(sat)}$	Collector-Emitter Saturation Voltage	$V_{GE}=15V, I_C=20A$	-	1.8	2.5	V
$V_{CE(sat)}$	Collector-Emitter Saturation Voltage	$V_{GE}=15V, I_C=35A$	-	2	2.7	V
$V_{GE(th)}$	Gate Threshold Voltage	$V_{CE}=V_{GE}, I_C=250\mu A$	2	-	6	V
Q_g	Total Gate Charge	$I_C=20A$	-	100	160	nC
Q_{ge}	Gate-Emitter Charge	$V_{CC}=480V$	-	24	-	nC
Q_{gc}	Gate-Collector Charge	$V_{GE}=15V$	-	40	-	nC
$t_{d(on)}$	Turn-on Delay Time	$V_{CE}=480V,$	-	50	-	ns
t_r	Rise Time	$I_C=20A,$	-	20	-	ns
$t_{d(off)}$	Turn-off Delay Time	$V_{GE}=15V,$	-	135	-	ns
t_f	Fall Time	$R_G=5\Omega$	-	190	380	ns
E_{on}	Turn-On Switching Loss	Inductive Load	-	0.3	-	mJ
E_{off}	Turn-Off Switching Loss		-	0.9	-	mJ
C_{ies}	Input Capacitance	$V_{GE}=0V$	-	3400	5440	pF
C_{oes}	Output Capacitance	$V_{CE}=30V$	-	75	-	pF
C_{res}	Reverse Transfer Capacitance	$f=1.0MHz$	-	50	-	pF

Ordering Information

AP20GT60W-HF-3TB : in RoHS-compliant halogen-free TO-3P, shipped in tubes (1440 pcs/carton)

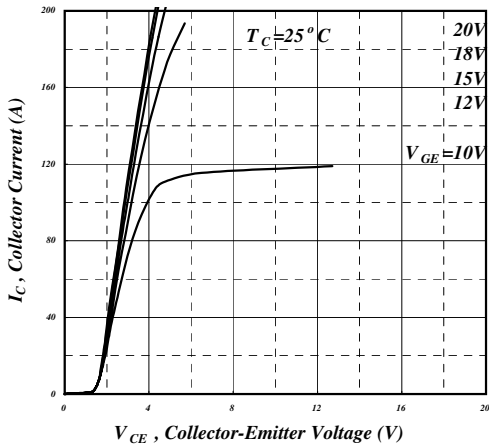

Fig 1. Typical Output Characteristics

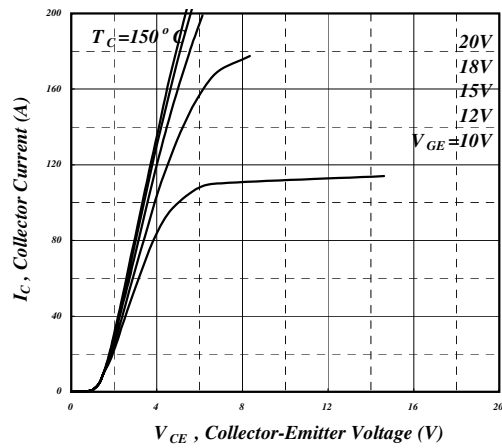

Fig 2. Typical Output Characteristics

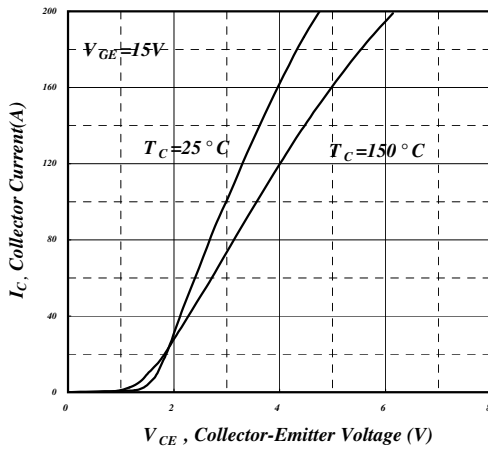

Fig 3. Typical Saturation Voltage Characteristics

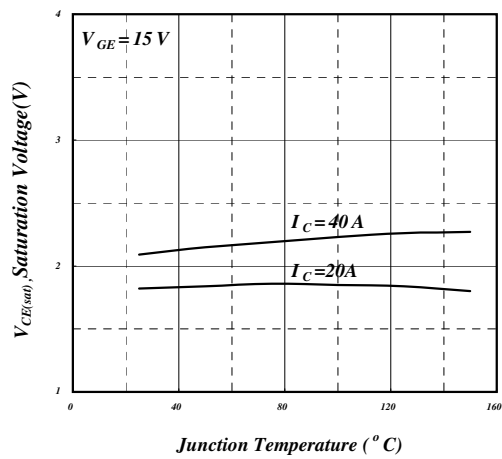

Fig 4. Typical Collector- Emitter Voltage vs. Junction Temperature

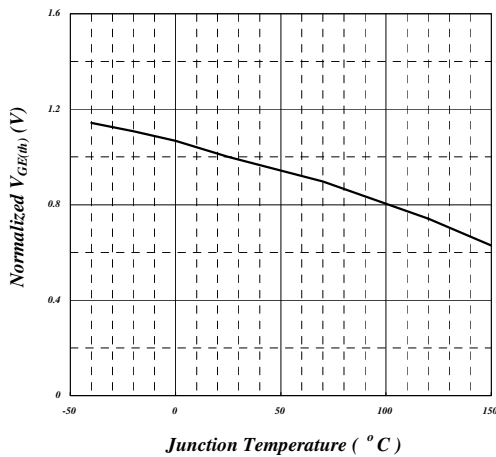

Fig 5. Gate Threshold Voltage vs. Junction Temperature

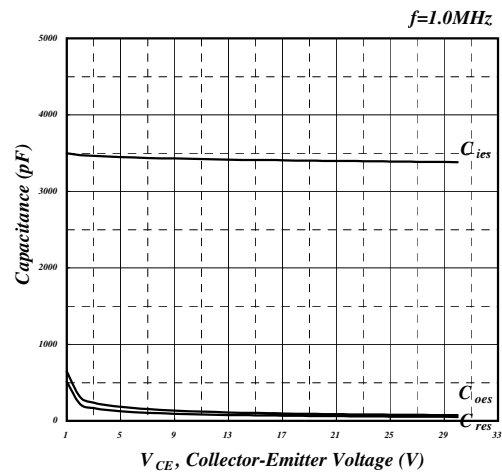

Fig 6. Typical Capacitance Characteristics

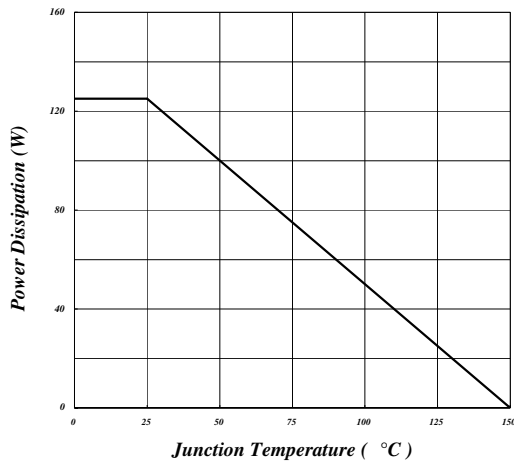

Fig 7. Power Dissipation vs. Junction Temperature

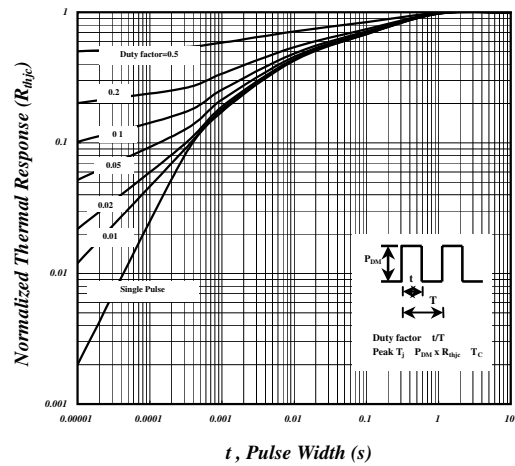

Fig 8. Effective Transient Thermal Impedance

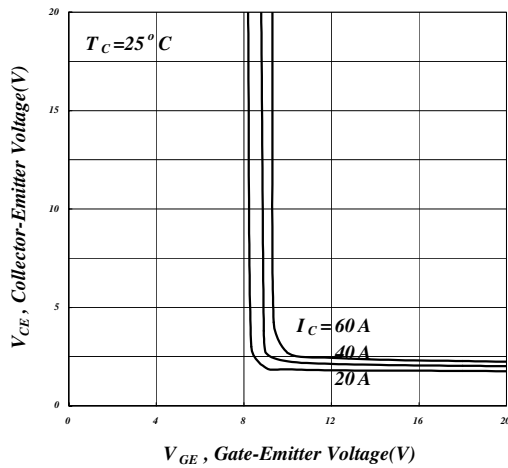

Fig 9. Saturation Voltage vs. V_{GE}

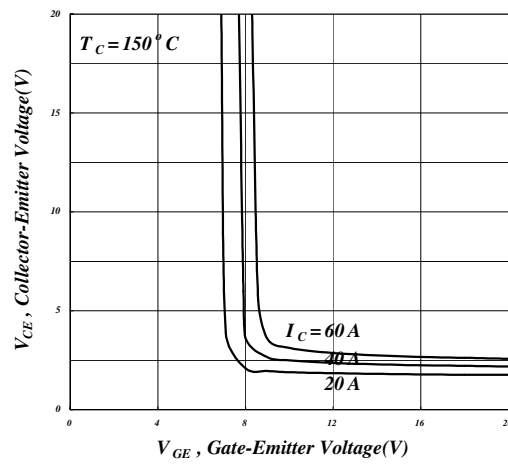

Fig 10. Saturation Voltage vs. V_{GE}

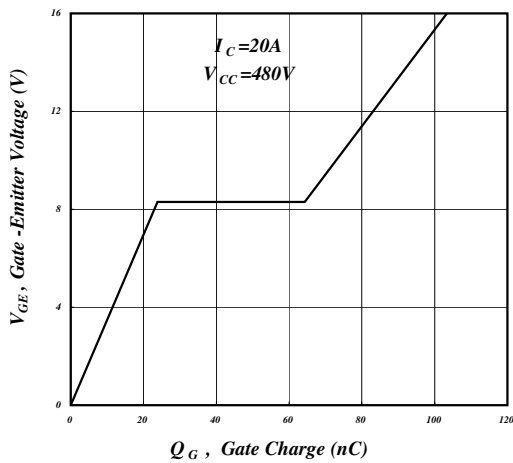

Fig 11. Gate Charge Characteristics

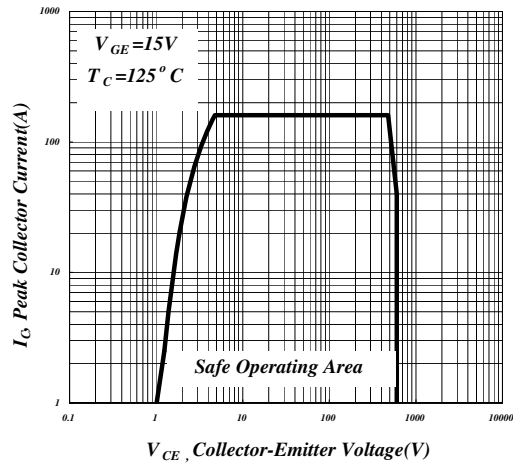
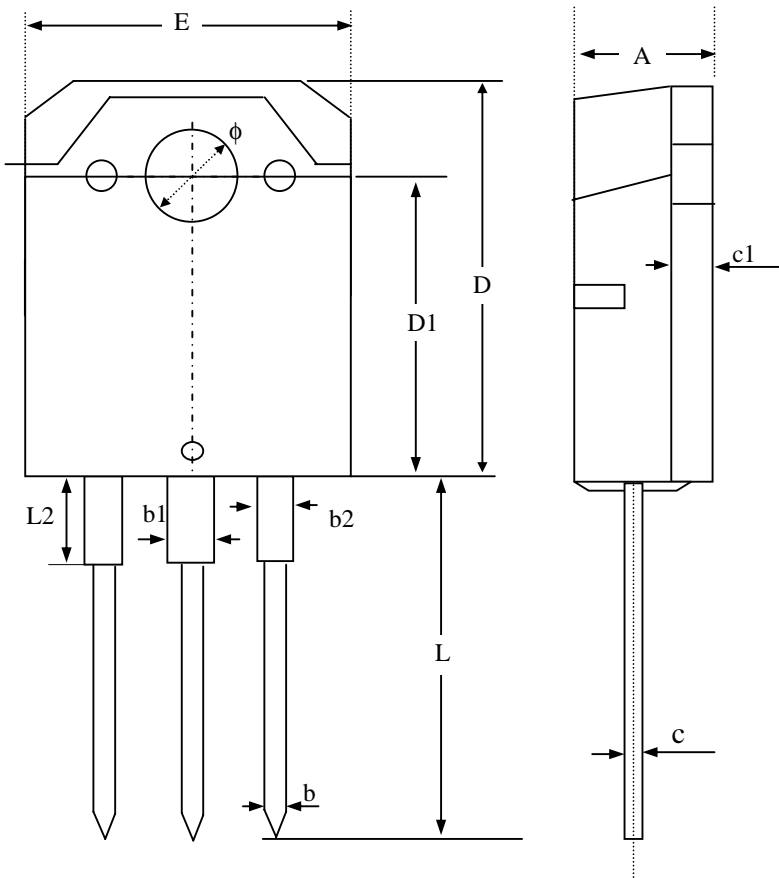

Fig 12. Turn-off SOA



Package Dimensions: TO-3P



SYMBOLS	Millimeters		
	MIN	NOM	MAX
A	4.50	4.80	5.10
b	0.80	1.00	1.30
b1	1.80	2.50	3.20
b2	1.30	--	2.30
c	0.40	0.60	0.90
c1	1.40	--	2.20
D	19.70	20.00	20.30
D1	14.70	15.00	15.30
E	15.30	--	16.10
e	4.45	5.45	6.45
L	17.50	--	20.50
L2	1.00	--	3.70
ϕ	3.00	3.20	3.40

1. All dimensions are in millimeters.
2. Dimensions do not include mold protrusions.

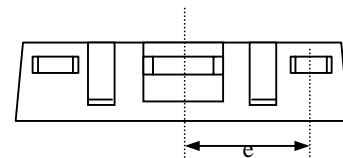

Marking Information:

