

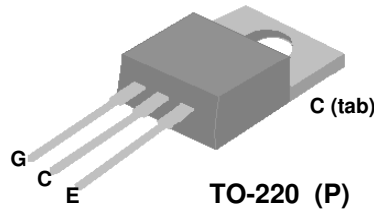

**N-Channel Insulated Gate Bipolar Power Transistor**

**High Speed Switching**  
**Low Saturation Voltage**  
**Typical  $V_{CE(sat)} = 1.8V$  at  $I_C=20A$**   
**Industry-standard TO-220 package**  
**RoHS-compliant, halogen-free**



$V_{CES}$	600V
$I_C$	20A

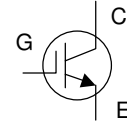

**Absolute Maximum Ratings**

Symbol	Parameter	Rating	Units
$V_{CES}$	Collector-Emitter Voltage	600	V
$V_{GE}$	Gate-Emitter Voltage	$\pm 20$	V
$I_C$ at $T_C=25^\circ C$	Collector Current	40	A
$I_C$ at $T_C=100^\circ C$	Collector Current	20	A
$I_{CM}$	Pulsed Collector Current <sup>1</sup>	160	A
$P_D$ at $T_C=25^\circ C$	Maximum Power Dissipation	104	W
$T_{STG}$	Storage Temperature Range	-55 to 150	$^\circ C$
$T_J$	Operating Junction Temperature Range	150	$^\circ C$

**Notes:**

1. Pulse width limited by maximum junction temperature.

**Thermal Data**

Symbol	Parameter	Value	Units
Rthj-c	Thermal Resistance, Junction-Case	1.2	$^\circ C/W$
Rthj-a	Thermal Resistance, Junction-Ambient	62	$^\circ C/W$

**Electrical Specifications at  $T_J=25^\circ C$  (unless otherwise specified)**

Symbol	Parameter	Test Conditions	Min.	Typ.	Max.	Units
$I_{GES}$	Gate-to-Emitter Leakage Current	$V_{GE}=\pm 20V, V_{CE}=0V$	-	-	$\pm 100$	nA
$I_{CES}$	Collector-Emitter Leakage Current	$V_{CE}=600V, V_{GE}=0V$	-	-	25	$\mu A$
$V_{CE(sat)}$	Collector-Emitter Saturation Voltage	$V_{GE}=15V, I_C=20A$	-	1.8	2.5	V
$V_{CE(sat)}$	Collector-Emitter Saturation Voltage	$V_{GE}=15V, I_C=35A$	-	2	-	V
$V_{GE(th)}$	Gate Threshold Voltage	$V_{CE}=V_{GE}, I_C=250\mu A$	2	-	7	V
$Q_g$	Total Gate Charge	$I_C=20A$	-	100	160	nC
$Q_{ge}$	Gate-Emitter Charge	$V_{CC}=480V$	-	24	-	nC
$Q_{gc}$	Gate-Collector Charge	$V_{GE}=15V$	-	40	-	nC
$t_{d(on)}$	Turn-on Delay Time	$V_{CE}=480V,$	-	50	-	ns
$t_r$	Rise Time	$I_C=20A,$	-	20	-	ns
$t_{d(off)}$	Turn-off Delay Time	$V_{GE}=15V,$	-	135	-	ns
$t_f$	Fall Time	$R_G=5\Omega$	-	190	380	ns
$E_{on}$	Turn-On Switching Loss	Inductive Load	-	0.3	-	mJ
$E_{off}$	Turn-Off Switching Loss		-	0.9	-	mJ
$C_{ies}$	Input Capacitance	$V_{GE}=0V$	-	3400	5440	pF
$C_{oes}$	Output Capacitance	$V_{CE}=30V$	-	75	-	pF
$C_{res}$	Reverse Transfer Capacitance	$f=1.0MHz$	-	50	-	pF

**Ordering Information**

**AP20GT60P-HF-3TB : in RoHS-compliant halogen-free TO-220, shipped in tubes (50pcs/tube)**

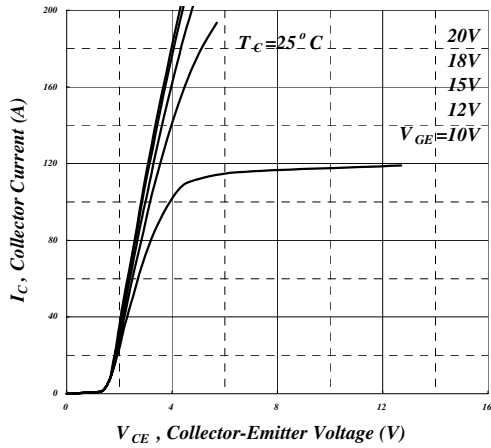

Fig 1. Typical Output Characteristics

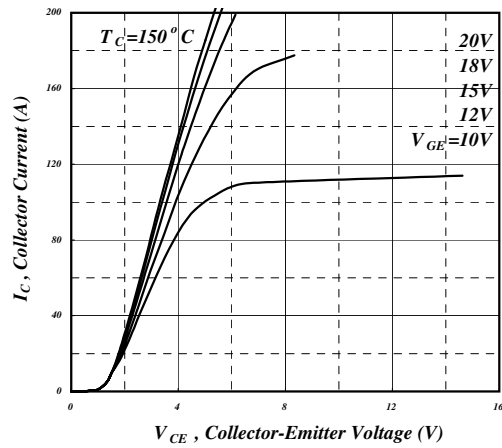

Fig 2. Typical Output Characteristics

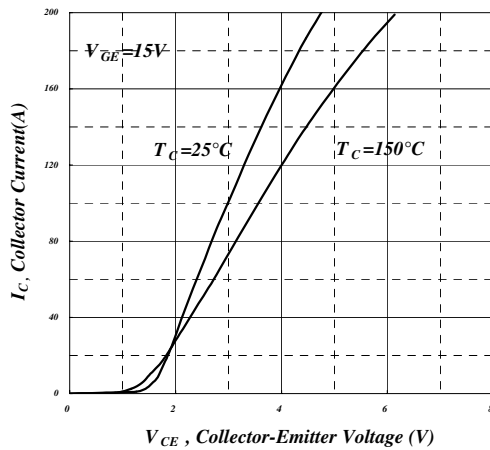

Fig 3. Typical Saturation Voltage Characteristics

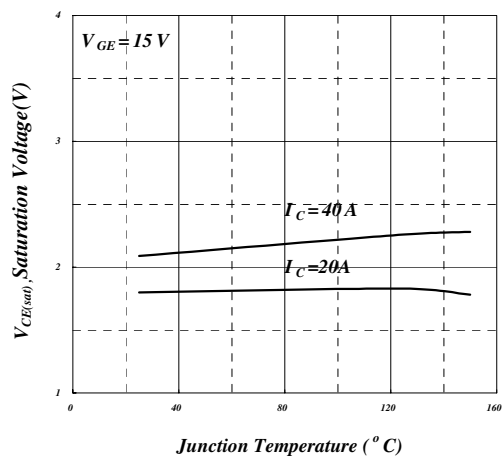

Fig 4. Typical Collector-Emitter Voltage vs. Junction Temperature

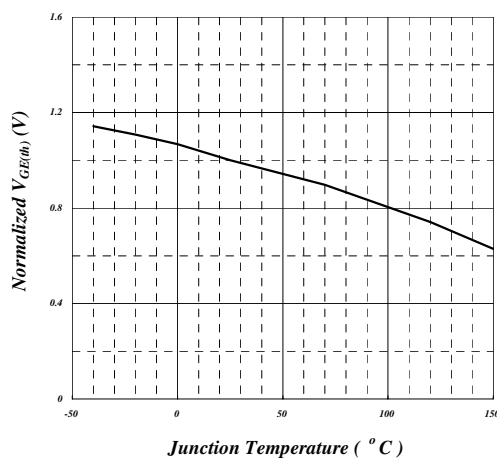

Fig 5. Gate Threshold Voltage vs. Junction Temperature

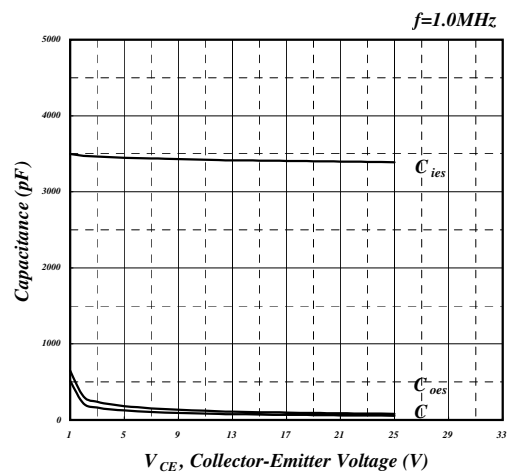

Fig 6. Typical Capacitance Characteristics

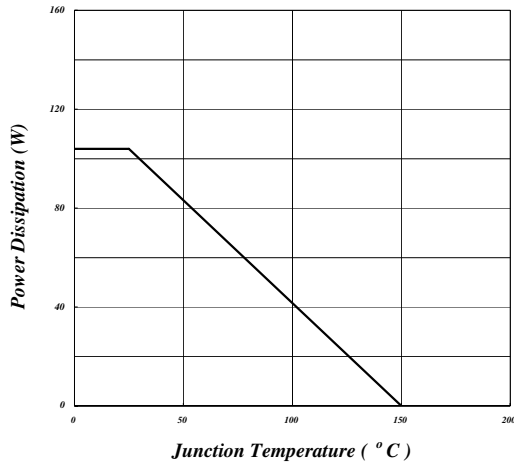

Fig 7. Power Dissipation vs. Junction Temperature

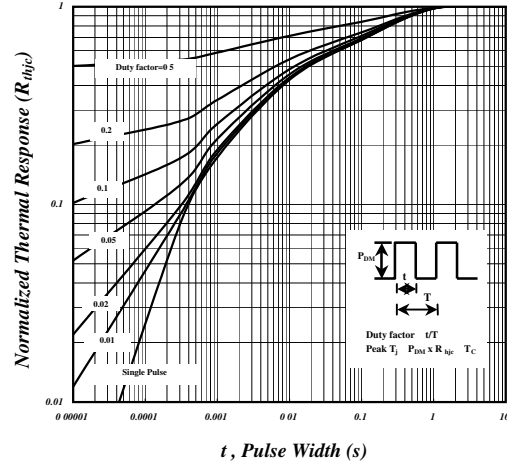

Fig 8. Effective Transient Thermal Impedance

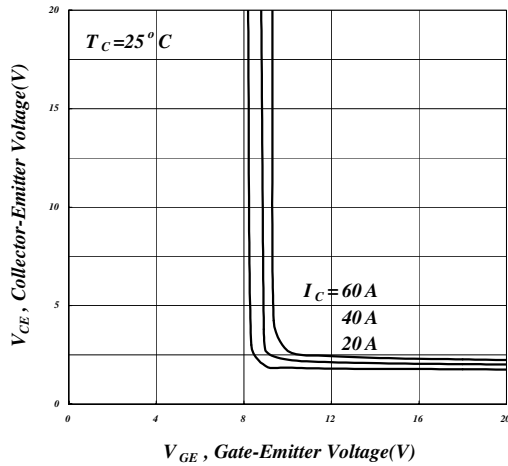

Fig 9. Saturation Voltage vs. V<sub>GE</sub>

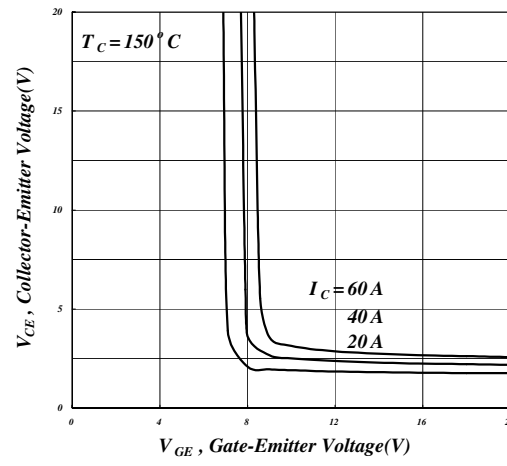

Fig 10. Saturation Voltage vs. V<sub>GE</sub>

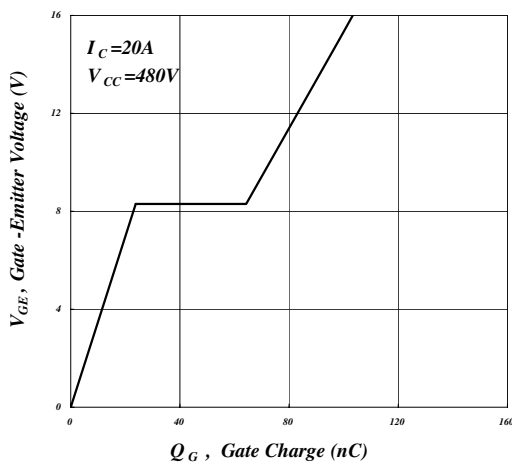

Fig 11. Gate Charge Characteristics

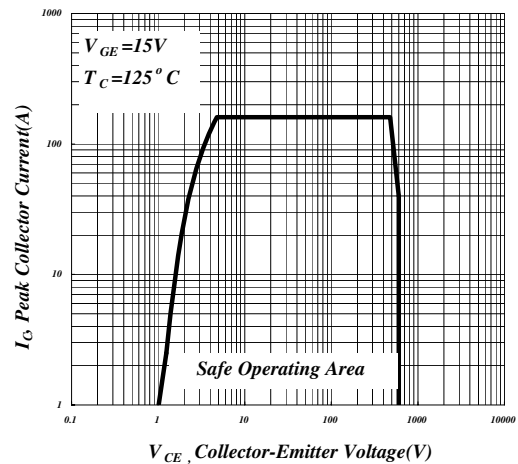
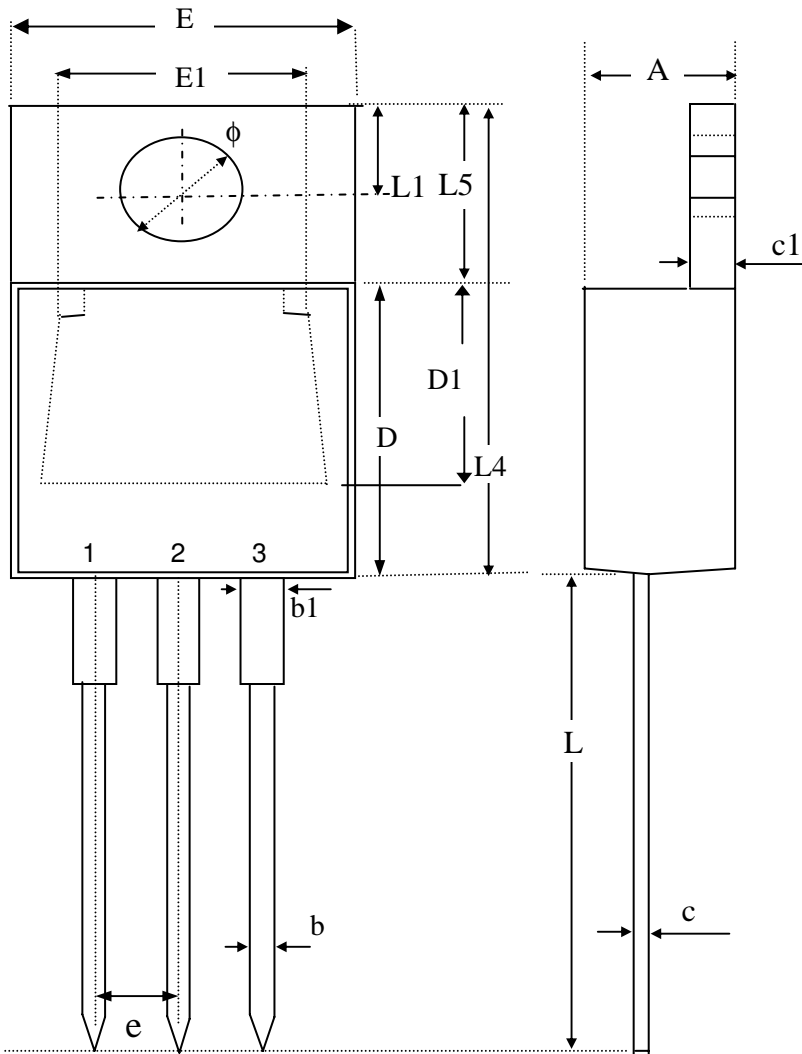

Fig 12. Turn-off SOA



**Package Dimensions: TO-220**



SYMBOLS	Millimeters		
	MIN	NOM	MAX
A	4.40	4.60	4.80
b	0.76	0.88	1.00
D	8.60	8.80	9.00
c	0.36	0.43	0.50
E	9.80	10.10	10.40
L4	14.70	15.00	15.30
L5	6.20	6.40	6.60
D1	5.10 REF.		
c1	1.25	1.35	1.45
b1	1.17	1.32	1.47
L	13.25	13.75	14.25
e	2.54 REF.		
L1	2.60	2.75	2.89
$\phi$	3.71	3.84	3.96
E1	7.4 REF.		

1. All dimensions are in millimeters.
2. Dimensions do not include mold protrusions.

**Marking Information:**

