

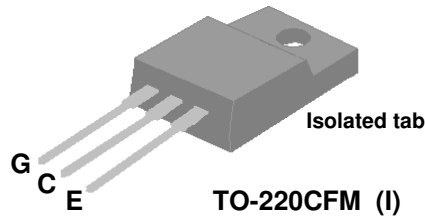

**N-Channel Insulated Gate Bipolar Power Transistor**

High Speed Switching  
Low Saturation Voltage  
Typical  $V_{CE(sat)} = 1.7V$  at  $I_C=12A$   
Industry-standard isolated package  
RoHS-compliant, halogen-free



$V_{CES}$	600V
$I_C$	20A

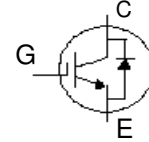

**Absolute Maximum Ratings**

Symbol	Parameter	Rating	Units
$V_{CES}$	Collector-Emitter Voltage	600	V
$V_{GE}$	Gate-Emitter Voltage	$\pm 20$	V
$I_C$ at $T_C=25^\circ C$	Collector Current	25	A
$I_C$ at $T_C=100^\circ C$	Collector Current	12	A
$I_{CM}$	Pulsed Collector Current <sup>1</sup>	50	A
$I_F$ at $T_C=100^\circ C$	Diode Forward Current	8	A
$I_{FM}$	Diode Pulse Forward Current	40	A
$P_D$ at $T_C=25^\circ C$	Maximum Power Dissipation	33	W
$T_{STG}$	Storage Temperature Range	-55 to 150	$^\circ C$
$T_J$	Operating Junction Temperature Range	150	$^\circ C$

**Notes:**

1. Pulse width limited by maximum junction temperature.

**Thermal Data**

Symbol	Parameter	Value	Units
$R_{thj-c}$	Thermal Resistance Junction-Case	3.8	$^\circ C/W$
$R_{thj-c(Diode)}$	Thermal Resistance Junction-Case	5	$^\circ C/W$
$R_{thj-a}$	Thermal Resistance Junction-Ambient	65	$^\circ C/W$

**Electrical Specifications at  $T_J=25^\circ C$  (unless otherwise specified)**

Symbol	Parameter	Test Conditions	Min.	Typ.	Max.	Units
$I_{GES}$	Gate-to-Emitter Leakage Current	$V_{GE}=\pm 20V, V_{CE}=0V$	-	-	$\pm 100$	nA
$I_{CES}$	Collector-Emitter Leakage Current	$V_{CE}=600V, V_{GE}=0V$	-	-	1	mA
$V_{CE(sat)}$	Collector-Emitter Saturation Voltage	$V_{GE}=15V, I_C=12A$	-	1.7	2.2	V
$V_{CE(sat)}$	Collector-Emitter Saturation Voltage	$V_{GE}=15V, I_C=25A$	-	1.9	-	V
$V_{GE(th)}$	Gate Threshold Voltage	$V_{CE}=V_{GE}, I_C=250\mu A$	2	-	6	V
$Q_g$	Total Gate Charge	$I_C=20A$	-	95	150	nC
$Q_{ge}$	Gate-Emitter Charge	$V_{CC}=480V$	-	16	-	nC
$Q_{gc}$	Gate-Collector Charge	$V_{GE}=15V$	-	35	-	nC
$t_{d(on)}$	Turn-on Delay Time	$V_{CE}=480V, I_C=20A,$	-	40	-	ns
$t_r$	Rise Time	$V_{GE}=15V,$	-	20	-	ns
$t_{d(off)}$	Turn-off Delay Time	$R_G=5\Omega,$	-	140	-	ns
$t_f$	Fall Time	Inductive Load	-	200	400	ns
$E_{on}$	Turn-On Switching Loss		-	0.1	-	mJ
$E_{off}$	Turn-Off Switching Loss		-	1	-	mJ
$C_{ies}$	Input Capacitance	$V_{GE}=0V$	-	2760	4400	pF
$C_{oes}$	Output Capacitance	$V_{CE}=30V$	-	65	-	pF
$C_{res}$	Reverse Transfer Capacitance	$f=1.0MHz$	-	40	-	pF

$V_F$	FRD Forward Voltage	$I_F=8A$	-	1.8	2.4	V
$t_{rr}$	FRD Reverse Recovery Time	$I_F=8A$	-	30	-	ns
$Q_{rr}$	FRD Reverse Recovery Charge	$di/dt = 100 A/\mu s$	-	30	-	nC

**Ordering Information**

**AP20GT60ASI-HF-3TB : in RoHS-compliant halogen-free TO-220CFM, shipped in tubes (50pcs/tube)**

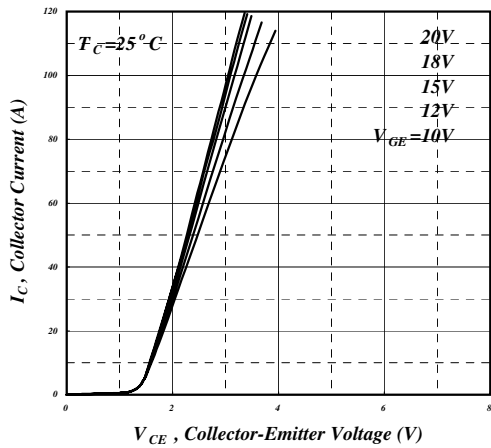

Fig 1. Typical Output Characteristics

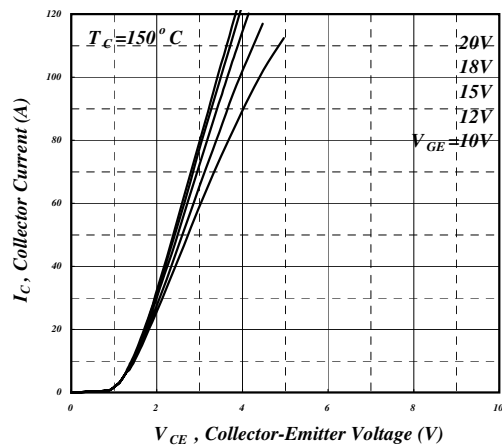

Fig 2. Typical Output Characteristics

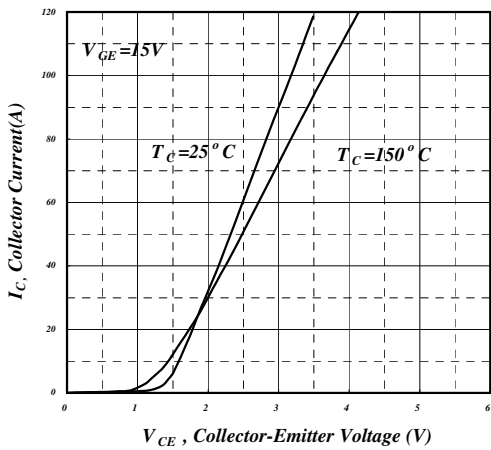

Fig 3. Typical Saturation Voltage Characteristics

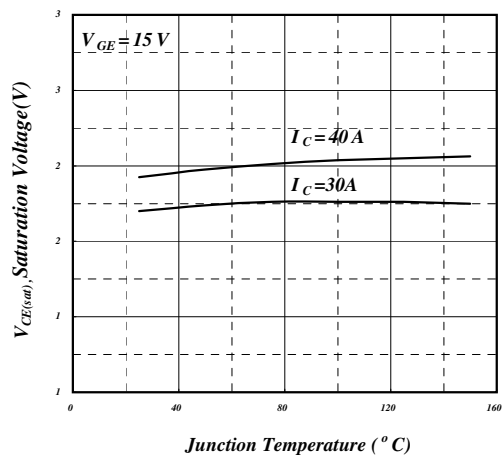

Fig 4. Typical Collector-Emitter Voltage vs. Junction Temperature

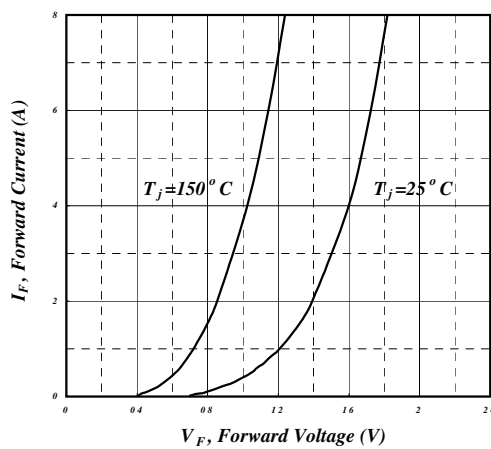

Fig 5. Forward Characteristics of the Diode

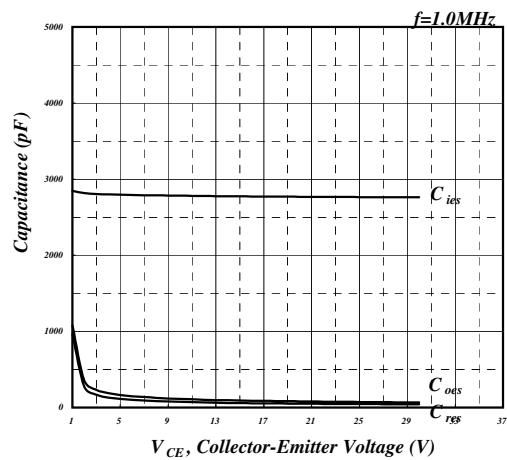

Fig 6. Typical Capacitance Characteristics

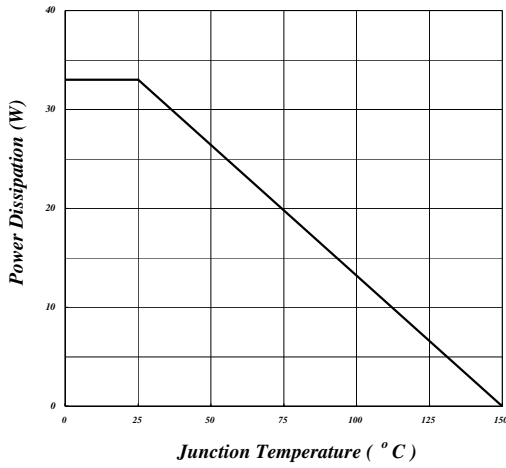

Fig 7. Power Dissipation vs. Junction Temperature

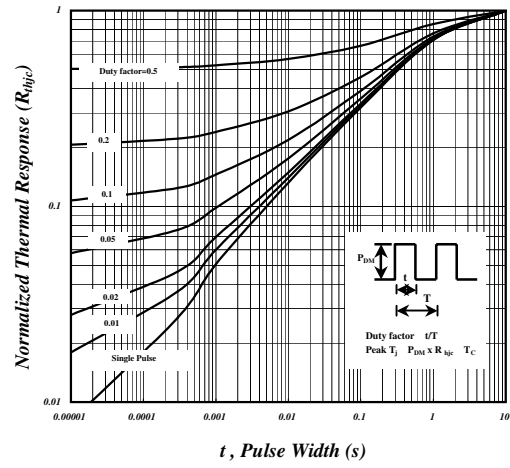

Fig 8. Effective Transient Thermal Impedance

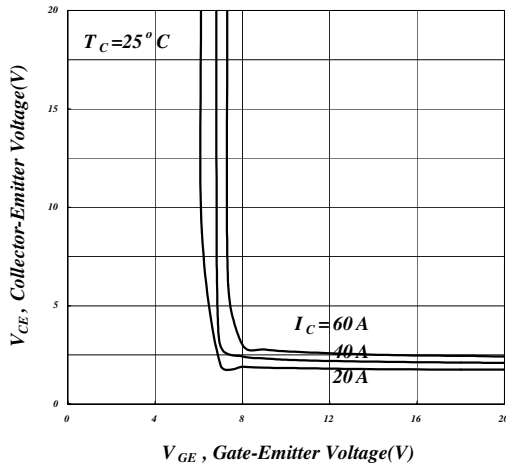

Fig 9. Saturation Voltage vs.  $V_{GE}$

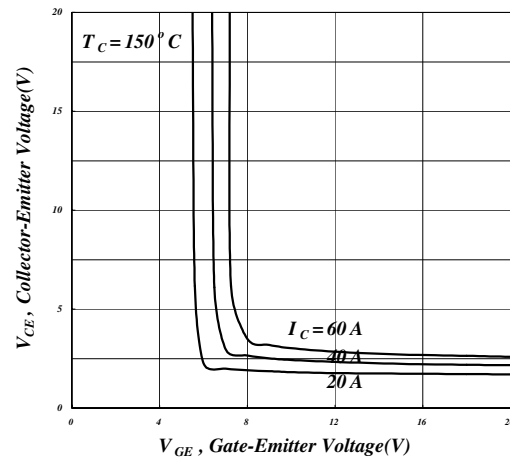

Fig 10. Saturation Voltage vs.  $V_{GE}$

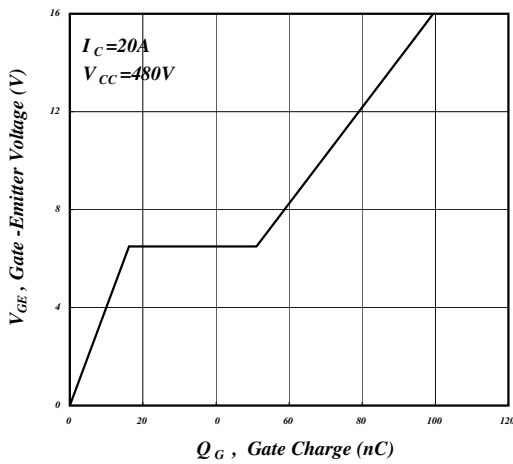

Fig 11. Gate Charge Characteristics

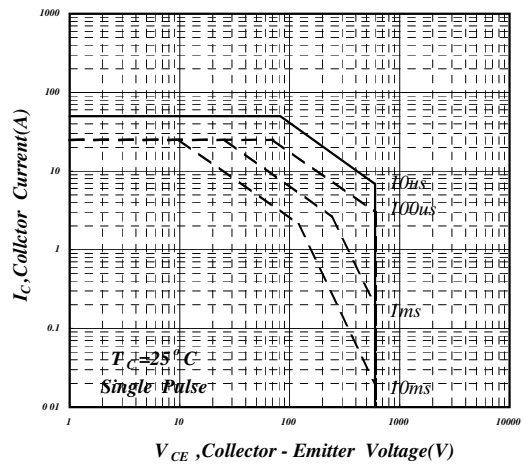
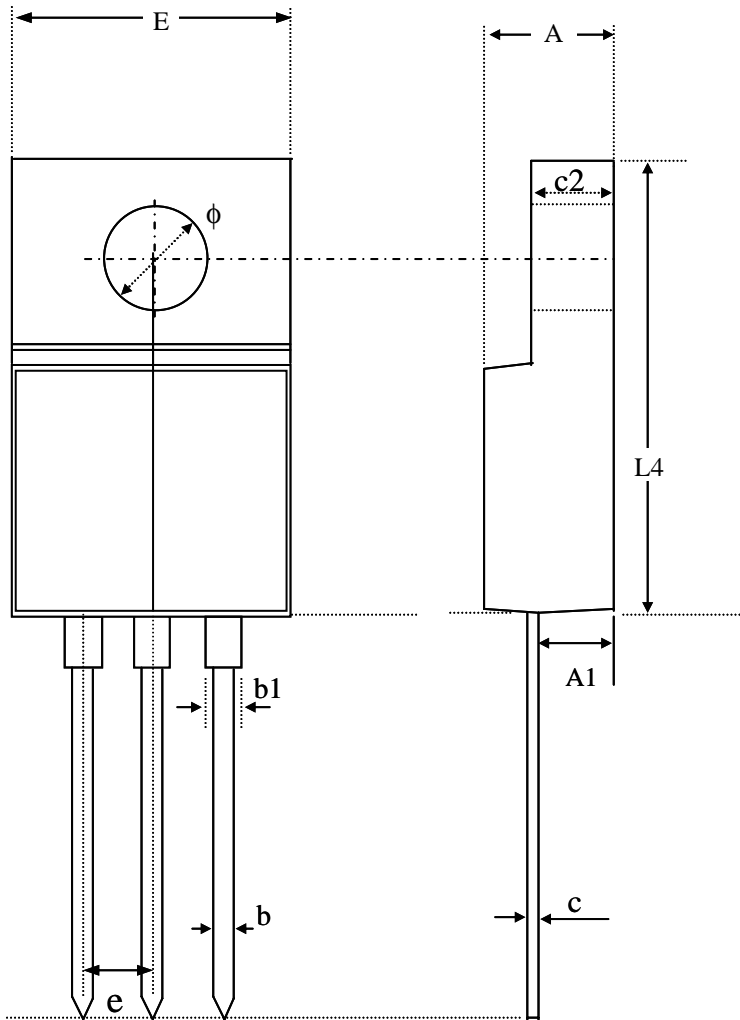

Fig 12. SOA Characteristics



**Package Dimensions: TO-220CFM**



SYMBOLS	Millimeters		
	MIN	NOM	MAX
<b>A</b>	4.30	4.60	4.90
<b>A1</b>	2.30	2.65	3.00
<b>b</b>	0.50	0.70	0.90
<b>b1</b>	0.95	1.20	1.50
<b>c</b>	0.45	0.65	0.80
<b>c2</b>	2.30	2.60	2.90
<b>E</b>	9.70	10.00	10.40
<b>L4</b>	14.70	15.40	16.10
$\phi$	----	3.20	----
<b>e</b>	----	2.54	----

1. All dimensions are in millimeters.
2. Dimensions do not include mold protrusions.

**Marking Information:**

