



**N-channel Enhancement-mode Power MOSFET**

- Fully isolated package**
- Simple Drive Requirement**
- Fast Switching Performance**
- RoHS-compliant, halogen-free**



$BV_{DSS}$	600V
$R_{DS(ON)}$	0.37Ω
$I_D$	11A

**Description**

Advanced Power MOSFETs from APEC provide the designer with the best combination of fast switching, low on-resistance and cost-effectiveness.

The AP11S60I-HF-3 is in the TO-220CFM isolated through-hole package which is widely used in commercial and industrial applications where a small PCB footprint or an attached isolated heatsink is required.

This device is well suited for use in high voltage applications such as off-line AC/DC converters.

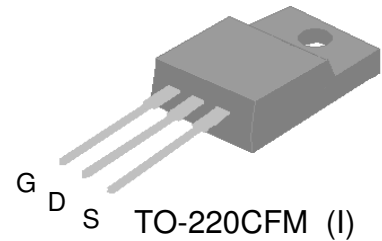

**Absolute Maximum Ratings**

Symbol	Parameter	Rating	Units
$V_{DS}$	Drain-Source Voltage	600	V
$V_{GS}$	Gate-Source Voltage	±20	V
$I_D$ at $T_C=25^\circ C$	Continuous Drain Current	11	A
$I_D$ at $T_C=100^\circ C$	Continuous Drain Current	6.9	A
$I_{DM}$	Pulsed Drain Current <sup>1</sup>	22	A
$P_D$ at $T_C=25^\circ C$	Total Power Dissipation	36.7	W
$P_D$ at $T_A=25^\circ C$	Total Power Dissipation	1.92	W
$T_{STG}$	Storage Temperature Range	-55 to 150	°C
$T_J$	Operating Junction Temperature Range	-55 to 150	°C

**Thermal Data**

Symbol	Parameter	Value	Units
Rthj-c	Maximum Thermal Resistance, Junction-case	3.4	°C/W
Rthj-a	Maximum Thermal Resistance, Junction-ambient	65	°C/W

**Ordering Information**

**AP11S60I-HF-3TB** : in RoHS-compliant halogen-free TO-220CFM, shipped in tubes (50pcs/tube, 1000pcs/box)



**Electrical Specifications at  $T_j=25^\circ\text{C}$  (unless otherwise specified)**

Symbol	Parameter	Test Conditions	Min.	Typ.	Max.	Units
$BV_{DSS}$	Drain-Source Breakdown Voltage	$V_{GS}=0V, I_D=250\mu A$	600	-	-	V
$R_{DS(ON)}$	Static Drain-Source On-Resistance <sup>2</sup>	$V_{GS}=10V, I_D=3.7A$	-	-	0.37	$\Omega$
$V_{GS(th)}$	Gate Threshold Voltage	$V_{DS}=V_{GS}, I_D=250\mu A$	2	-	4	V
$g_{fs}$	Forward Transconductance	$V_{DS}=10V, I_D=5A$	-	10	-	S
$I_{DSS}$	Drain-Source Leakage Current	$V_{DS}=480V, V_{GS}=0V$	-	-	25	$\mu A$
$I_{GSS}$	Gate-Source Leakage	$V_{GS}=\pm 20V, V_{DS}=0V$	-	-	$\pm 100$	nA
$Q_g$	Total Gate Charge	$I_D=5A$	-	38	61	nC
$Q_{gs}$	Gate-Source Charge	$V_{DS}=480V$	-	6.5	-	nC
$Q_{gd}$	Gate-Drain ("Miller") Charge	$V_{GS}=10V$	-	19	-	nC
$t_{d(on)}$	Turn-on Delay Time	$V_{DD}=300V$	-	11	-	ns
$t_r$	Rise Time	$I_D=5A$	-	13	-	ns
$t_{d(off)}$	Turn-off Delay Time	$R_G=3.3\Omega$	-	49	-	ns
$t_f$	Fall Time	$V_{GS}=10V$	-	17	-	ns
$C_{iss}$	Input Capacitance	$V_{GS}=0V$	-	1065	1704	pF
$C_{oss}$	Output Capacitance	$V_{DS}=25V$	-	625	-	pF
$C_{riss}$	Reverse Transfer Capacitance	$f=1.0\text{MHz}$	-	5	-	pF
$R_g$	Gate Resistance	$f=1.0\text{MHz}$	-	4.6	9.2	$\Omega$

**Source-Drain Diode**

Symbol	Parameter	Test Conditions	Min.	Typ.	Max.	Units
$V_{SD}$	Forward On Voltage <sup>2</sup>	$I_S=5A, V_{GS}=0V$	-	0.8	-	V
$t_{rr}$	Reverse Recovery Time	$I_S=5A, V_{GS}=0V$	-	260	-	ns
$Q_{rr}$	Reverse Recovery Charge	$di/dt=100A/\mu s$	-	3.8	-	$\mu C$

**Notes:**

1. Pulse width limited by maximum junction temperature.
2. Pulse width <300us, duty cycle < 2%

THIS PRODUCT IS SENSITIVE TO ELECTROSTATIC DISCHARGE, PLEASE HANDLE WITH CAUTION.

USE OF THIS PRODUCT AS A CRITICAL COMPONENT IN LIFE SUPPORT OR OTHER SIMILAR SYSTEMS IS NOT AUTHORIZED.

APEC DOES NOT ASSUME ANY LIABILITY ARISING OUT OF THE APPLICATION OR USE OF ANY PRODUCT OR CIRCUIT DESCRIBED HEREIN; NEITHER DOES IT CONVEY ANY LICENSE UNDER ITS PATENT RIGHTS, NOR THE RIGHTS OF OTHERS.

APEC RESERVES THE RIGHT TO MAKE CHANGES WITHOUT FURTHER NOTICE TO ANY PRODUCTS HEREIN TO IMPROVE RELIABILITY, FUNCTION OR DESIGN.



## Typical Electrical Characteristics

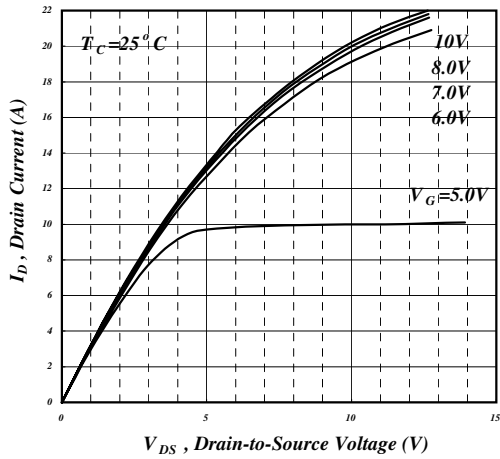

Fig 1. Typical Output Characteristics

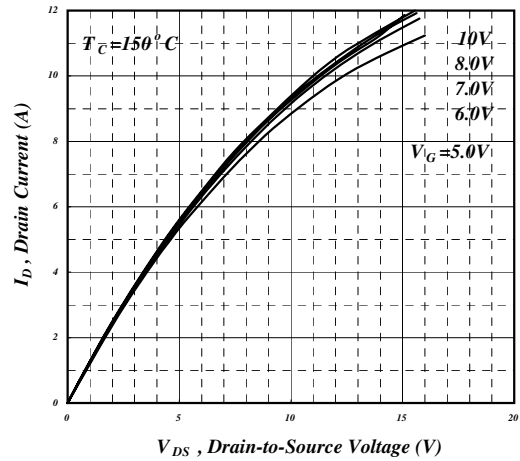

Fig 2. Typical Output Characteristics

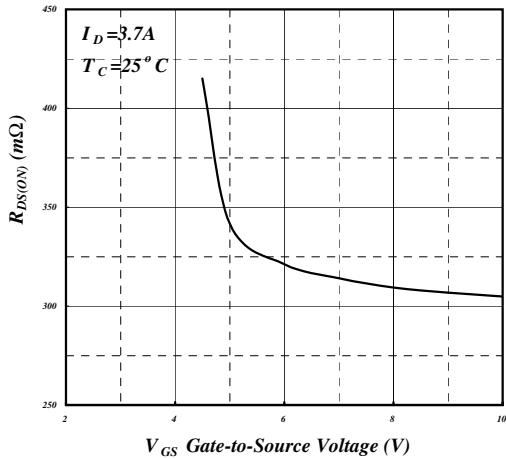

Fig 3. On-Resistance v.s. Gate Voltage

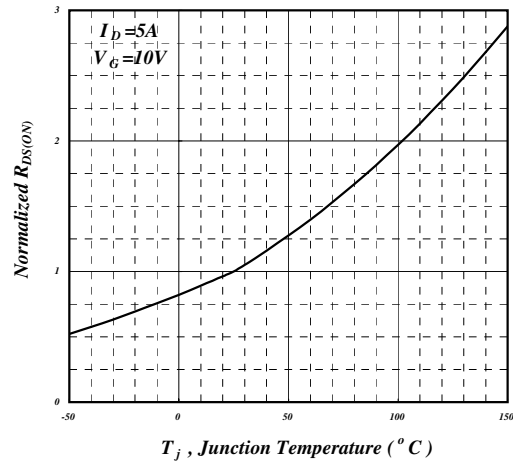

Fig 4. Normalized On-Resistance vs. Junction Temperature

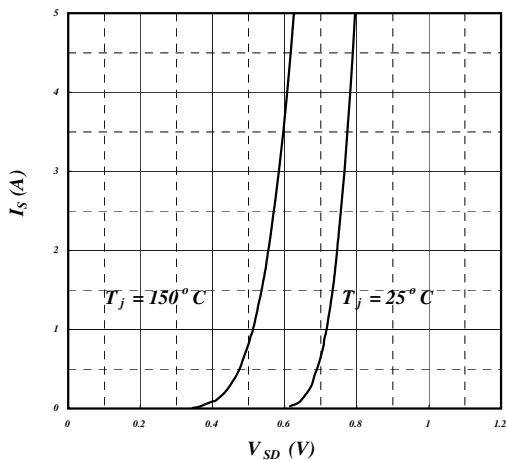

Fig 5. Forward Characteristic of Reverse Diode

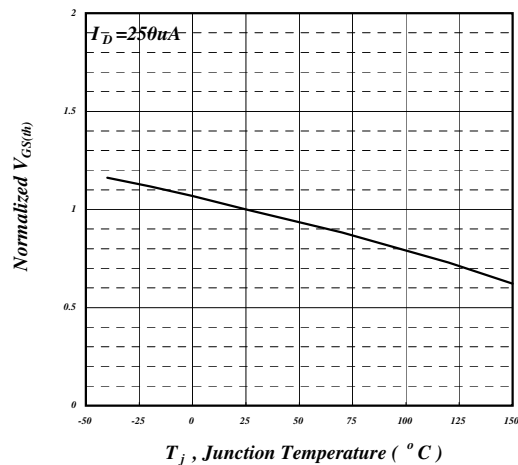

Fig 6. Gate Threshold Voltage vs. Junction Temperature



Typical Electrical Characteristics (cont.)

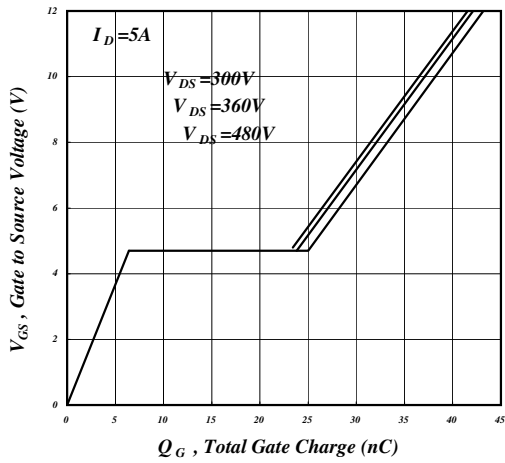

Fig 7. Gate Charge Characteristics

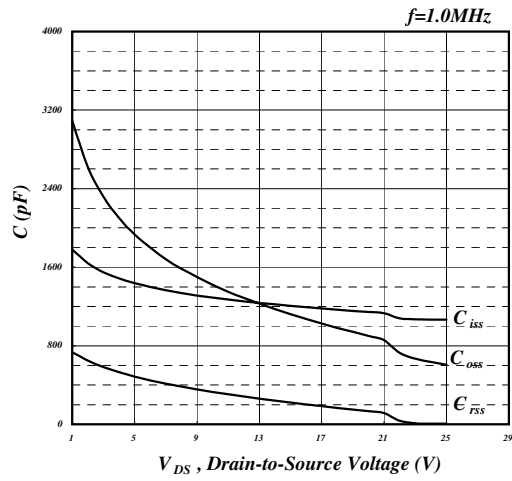

Fig 8. Typical Capacitance Characteristics

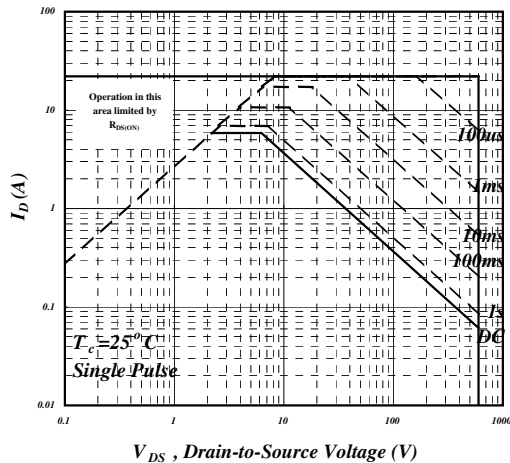

Fig 9. Maximum Safe Operating Area

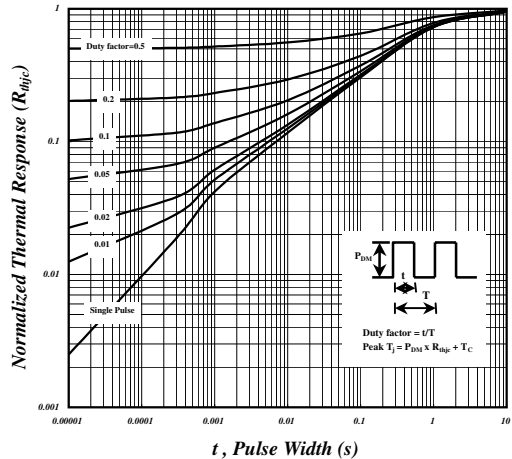

Fig 10. Effective Transient Thermal Impedance

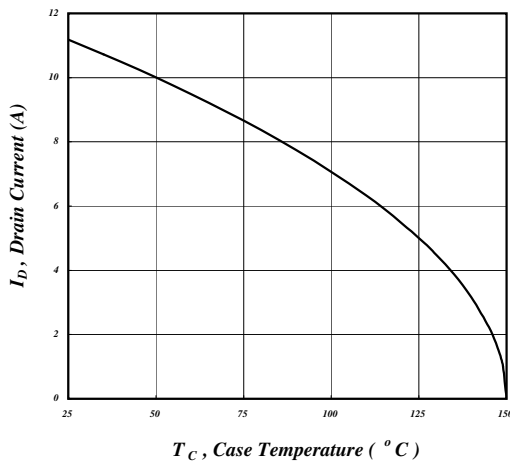

Fig 11. Maximum Continuous Drain Current v.s. Case Temperature

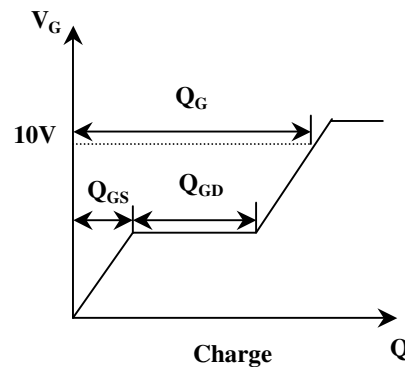
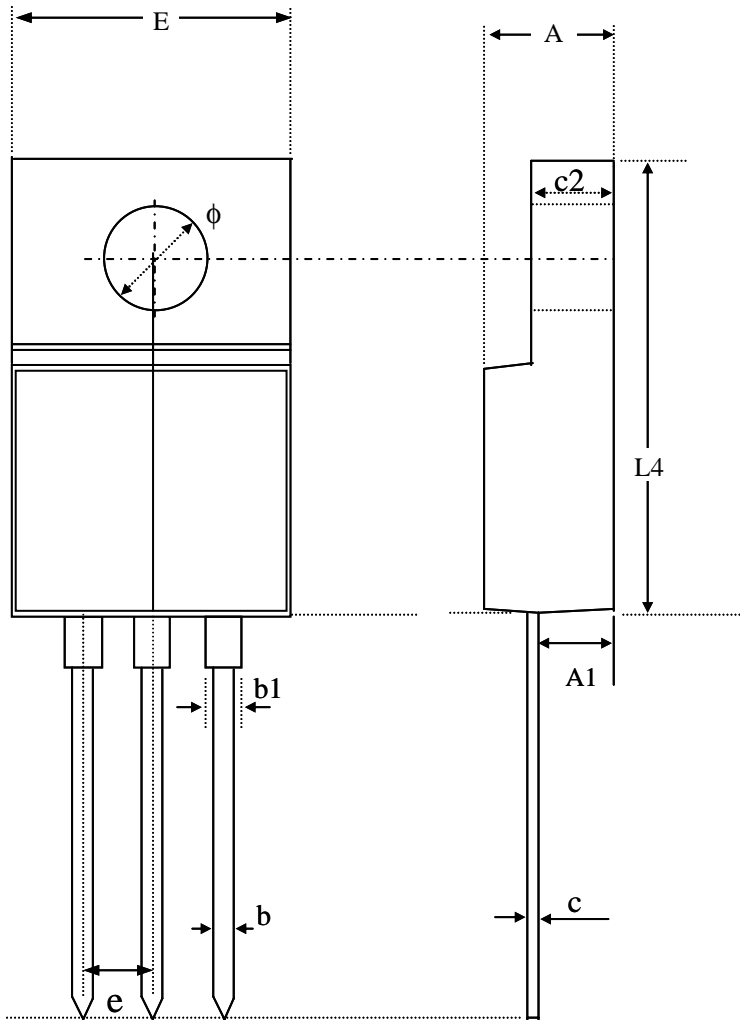

Fig 12. Gate Charge Waveform



**Package Dimensions: TO-220CFM**



SYMBOLS	Millimeters		
	MIN	NOM	MAX
<b>A</b>	4.30	4.60	4.90
<b>A1</b>	2.30	2.65	3.00
<b>b</b>	0.50	0.70	0.90
<b>b1</b>	0.95	1.20	1.50
<b>c</b>	0.45	0.65	0.80
<b>c2</b>	2.30	2.60	2.90
<b>E</b>	9.70	10.00	10.40
<b>L4</b>	14.70	15.40	16.10
$\phi$	----	3.20	----
<b>e</b>	----	2.54	----

1. All dimensions are in millimeters.
2. Dimensions do not include mold protrusions.

**Marking Information:**

