



VRLA Rechargeable Battery

BPL210-12 (BPL210-12FR)



FEATURES

- Maintenance free(no water topping-up required).
- No free acid(Non-spillable battery).
- Low self-discharge rate, lower than 3% capacity loss per month.
- Can be used in any orientation(excluding used inverted).
- Filtered with explosion proof filter.
- Flame-arrestor is installed to ensure safety.
- Carry handles for easy installation.
- Absorbent Glass Mat technology for efficient gas recombination.

APPLICATION

- UPS
- Telecom



SPECIFICATIONS

Nominal Voltage	12 V
Nominal Capacity	210.0Ah @ 20 hour rate F.V.(1.75V/cell)
Approx. Weight	73.2g(161.4lbs.)
Terminals	B9 (Fitting M8 bolt & nut) I3 is optional
Internal Resistance	≤2.5mΩ (Fully Charged)
Max. Discharge Current	800 A (5 sec.)
Max. Charge Current	63 A
Operating Temperature Range	Charge : 0°C~40°C(32°F~104°F) Discharge : -20°C~50°C(-4°F~122°F) Storage : -20°C~40°C(-4°F~104°F)
Container Material	ABS(UL94-HB, UL94-V0 is optional)

ISO 9001	
ISO14001	
UL	
CE	
<ul style="list-style-type: none"> ● IEC 60896-21/22 ● JIS C 8704-2 ● GB/T 19638.2 	

DIMENSION(mm/inch)

OUTER DIMENSIONS

TERMINAL TYPE

- **Length**
522±2 (20.55±0.08)
- **Width**
240±2 (9.45±0.08)
- **Container Height**
216±2 (8.50±0.08)
- **Total Height**
B9:240±2 (9.45±0.08)
I3:220±2 (8.66±0.08)

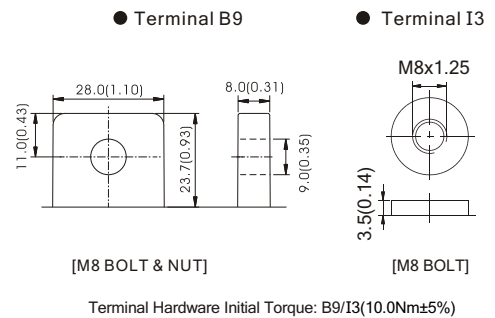
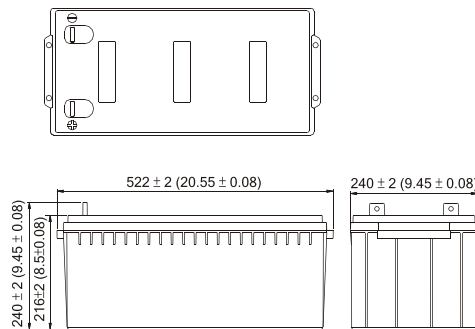

Constant power discharge characteristics at 25 °C/77 °F

Unit: W

F.V. (V/cell) \ Discharge Time	15 Min	30 Min	1 Hr	3 Hr	5 Hr	10 Hr	20 Hr
1.80V	3910	2664	1529	612.0	422.1	235.8	124.1
1.75V	4091	2766	1574	624.3	428.4	239.4	126.0
1.70V	4217	2829	1603	630.0	430.8	240.6	126.6
1.65V	4314	2868	1622	634.5	432.3	241.2	127.0
1.60V	4400	2898	1638	638.1	433.5	241.2	127.0

Constant current discharge characteristics at 25 °C/77 °F

Unit: A

F.V. (V/cell) \ Discharge Time	15 Min	30 Min	1 Hr	3 Hr	5 Hr	10 Hr	20 Hr
1.80V	340	226	128	51.0	35.2	19.7	10.34
1.75V	356	234	132	52.0	35.7	19.9	10.50
1.70V	367	240	135	52.5	35.9	20.1	10.55
1.65V	375	243	136	52.9	36.0	20.1	10.58
1.60V	383	246	138	53.2	36.1	20.1	10.58

All data shall be changed without prior notice, BB reserves the right to explain and update the information contained hereinto.