

## Short Form Data Sheet

Part number scheme

**H D 15 N 45 KNX**  
1 2 3 4 5 6

- 1) Package designation
- 2) Diode designation (i.e. Rectifier)
- 3) Series number
- 4) Designates standard recovery time
- 5) Voltage Multiplier (example: 45 x 100 = 4500)
- 6) Proprietary suffix

### Features:

- ✓ All diffused silicone.
- ✓ Disk press package (nick named, Hockey Puck)
- ✓ Metal and ceramic package construction.
- ✓ Double side cooling.

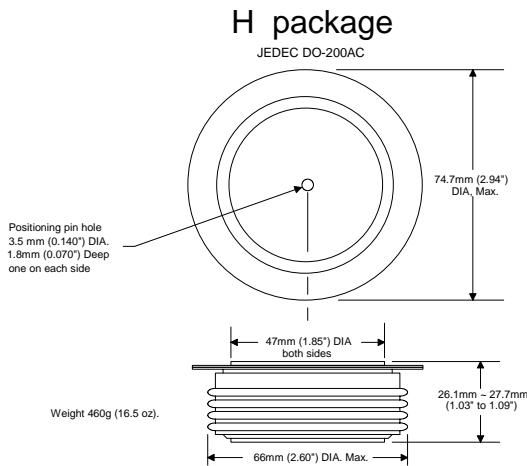

## Voltage

Parameter	Symbol	Rating	Units
Maximum Repetitive Reverse Voltage <small>Notes: 1, 3, 4, 5, 6</small>	$V_{RRM}$	3000 ~ 5000	Volts
Maximum non repetitive Surge of Reverse Voltage <small>Notes: 2, 3, 4, 5, 6</small>	$V_{RSM}$	$V_{RRM} + 100$	Volts
<small>Note 1: <math>T_J</math> 25°C. Note 2: <math>T_J</math> 125°C. Note 3: Measured at the peak of the sine wave. Note 4: Below 0°C derate <math>V_{DRM}</math> and <math>V_{RRM}</math> 10%.                      Note 5: <math>V_{DRM}</math> and <math>V_{RRM}</math> have <math>I_{DRM}</math>, <math>I_{RRM}</math> of up to 150mA. Note 6: <math>V_{DR}</math> and <math>V_{RR}</math> have typical <math>I_{DR}</math>, <math>I_{RR}</math> of 7~15mA. Note 7: For DC applications derate <math>V_{DRM}</math> 45%.</small>			
Specifying voltage:	3500V, HD15N35 3000V, HD15N30	4500V, HD15N45 4000V, HD15N40	5000V, HD15N50
Above 5000V inquire for availability.			

## Current

Parameter	Symbol	Rating	Units
Maximum, Average Current <small>Notes: 3, 4</small>	$I_{F(AVE)}$	1,550	Amperes
Maximum, RMS Current <small>Notes: 3, 4</small>	$I_{F(RMS)}$	2,500	Amperes
Maximum non repetitive Surge Current with no reverse voltage reapplied. <small>Notes: 2, 4</small>	$I_{FSM} 0\% V_{RRM}$	14.3	kA
$I_{RR}$ = Typical Repetitive, Reverse, Current. <small>Note: 1</small>	$I_{RR}$	7 ~ 15	mA
Maximum Forward Voltage drop at Maximum Forward Current	$V_{FM} @ I_{FM}$	2.2 @ 3000	V @ A
$I_{RRM}$ = Maximum (threshold), Repetitive, Reverse, Current. <small>Note: 1</small>	$I_{RRM}$	150	mA
Fuse's absolute maximum $I^2 t$ with no reverse voltage reapplied <small>Note: 2, 4</small>	$I^2 t, 0\% V_{RR}$	1,826	kA
Fuse's absolute maximum $I^2 t$ with 50% reverse voltage reapplied <small>Note: 2, 4</small>	$I^2 t, 50\% V_{RR}$	1,292	kA
Reverse Recovery Charge ( $C_s$ = Stored Charge)	$Q_{RR}$	Consult factory	$\mu C_s$
<small>Note 1: <math>T_C</math> 150°C. Note 2: <math>T_J</math> 125°C. Note 3: <math>T_{Case}</math> 55°C, double side air cooled. Note 4: 180° conduction, 60Hz sine wave.</small>			

## Thermal & Mechanical

Parameter	Symbol	Rating	Units
Operating Temperature Range	$T_J$	-40° ~ 180°	°Celsius
Maximum Thermal resistance, Junction to Case <small>Notes: 1, 3, 5</small>	$R_{th-J-C}$	0.025	°C/W
Mounting Pressure (i.e. Force)	F	2300 ~ 2700	kg
		5000 ~ 6000	lb.
Weight	Weight	460	Grams
		16.5	oz.
<small>Note 1: Recommended mounting pressure applied                      Note 2: Mounting surfaces flat and greased                      Note 3: Double side cooled                      Note 4: Case Temperature measured at cathode                      Note 5: 180° on-state                      flange</small>			