

## Y package

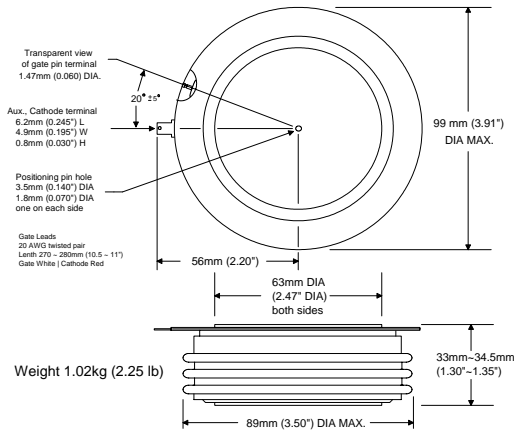

Part number scheme

**Y T 21 N 12 KNX**  
1 2 3 4 5 6

- 1) Package designation
- 2) Thyristor designation (i.e. SCR)
- 3) Series number
- 4) Designates standard recovery time
- 5) Voltage Multiplier (example: 12 x 100 = 1200)
- 6) Proprietary suffix

### Features:

- ✓ All diffused silicone.
- ✓ Center amplifying gate.
- ✓ Standard recovery time for phase control applications.
- ✓ Disk press package (nick named, Hockey Puck)
- ✓ Metal and ceramic package construction.
- ✓ Double side cooling.

## Voltage

Parameter	Symbol	Rating	Units
Maximum Repetitive Off-State Voltage <small>Notes: 1, 3, 4, 5, 6, 7</small>	V <sub>DRM</sub>	800 ~ 1600	Volts
Maximum Repetitive Reverse Voltage <small>Notes: 1, 3, 4, 5, 6</small>	V <sub>RRM</sub>	800 ~ 1600	Volts
Maximum non repetitive Surge of Reverse Voltage <small>Notes: 2, 3, 4, 5, 6</small>	V <sub>RSM</sub>	V <sub>RRM</sub> + 100	Volts
Critical rate of rising off-state Voltage, Linear to 80% of V <sub>DRM</sub> <small>Note: 2</small>	dv/dt	500	V/μs
<small>Note 1: T<sub>J</sub> 25°C. Note 2: T<sub>J</sub> 125°C. Note 3: Measured at the peak of the sine wave, Note 4: Below 0°C derate V<sub>DRM</sub> and V<sub>RRM</sub> 10%.                      Note 5: V<sub>DRM</sub> and V<sub>RRM</sub> have I<sub>DRM</sub>, I<sub>RRM</sub> of up to 50mA. Note 6: V<sub>DR</sub> and V<sub>RR</sub> have typical I<sub>DR</sub>, I<sub>RR</sub> of 3-7mA. Note 7: For DC applications derate V<sub>DRM</sub> 45%.</small>			

## Gate

Parameter	Symbol	Rating			Units
		Temp.	Typ.	Max.	
Gate Trigger Voltage <small>Note 3</small>	V <sub>GT</sub>	-20°C	2.3 ~ 2.8	3	Volts
		25°C	1.9 ~ 2.4		
		125°C	1.4 ~ 1.6		
Maximum Gate Trigger Current <small>Notes 1, 3</small>	I <sub>GT</sub>		300		mA
Minimum anode cathode Current to Latch on-state <small>Notes 1, 5</small>	I <sub>L</sub>		500		mA
Maximum peak non repetitive Gate Voltage <small>Notes 2, 3</small>	V <sub>GM</sub>		8.4		Volts
Maximum Negative Gate Voltage <small>Notes 2, 4</small>	-V <sub>GM</sub>		5		Volts
Maximum non repetitive Gate Current <small>Notes 2, 3</small>	I <sub>GM</sub>		3.7		Amperes
Maximum Repetitive Gate Current <small>Notes 2, 3</small>	I <sub>GRM</sub>		1		Amperes
Average Gate Power (recommended) <small>Note 2, 3</small>	P <sub>G(AVE)</sub>		0.9 ~ 3		Watts
<small>Note 1: T<sub>J</sub> 25°C. Note 2: T<sub>J</sub> 125°C. Note 3: Rectangular pulse, t<sub>p</sub> ≤ 8.3 ms. Note 4: Rectangular -V<sub>DC</sub> pulse, t<sub>p</sub> ≤ 8.3 ms. Note 5: Test conditions: I<sub>DC</sub> R<sub>L</sub> = 12Ω.</small>					

## Current

Parameter	Symbol	Rating	Units
Maximum, Average, On state, Current <small>Notes: 3, 4</small>	I <sub>T(AVE)</sub>	2040	Amperes
Maximum, RMS, On state, Current <small>Notes: 3, 4</small>	I <sub>T(RMS)</sub>	3140	Amperes
Maximum non repetitive, Surge, On state, Current, with no reverse voltage reapplied. <small>Notes: 2, 4</small>	I <sub>TSM</sub> 0% V <sub>RRM</sub>	29.5	kA
Maximum non repetitive, Surge, On state, Current, with maximum reverse voltage reapplied. <small>Notes: 2, 4</small>	I <sub>TSM</sub> 100% V <sub>RRM</sub>	25	kA
Critical rate of rising On-state Current, non repetitive <small>Note: 6, 7</small>	di/dt	500	A/μs
Maximum On-State Forward Voltage <small>Notes: 1, 4</small>	V <sub>TM @ 3000A</sub>	1.6	Volts
Holding Current <small>Notes: 1, 5</small>	I <sub>H</sub>	800	mA
I <sub>DRM</sub> = Maximum (threshold), Repetitive, Off-State, Current. <small>Note: 1</small>	I <sub>DRM</sub> & I <sub>RRM</sub>	50	mA
I <sub>RRM</sub> = Maximum (threshold), Repetitive, Reverse, Current. <small>Note: 1</small>			
Fuse's absolute maximum I <sup>2</sup> t with no reverse voltage reapplied <small>Note: 2, 4</small>	I <sup>2</sup> t, 0% V <sub>RRM</sub>	4160	kA
Fuse's absolute maximum I <sup>2</sup> t with up to 80% of V <sub>RRM</sub> reapplied <small>Note: 2, 4</small>	I <sup>2</sup> t, ≤ 80% V <sub>RRM</sub>	2640	kA
Reverse Recovery Charge (C <sub>S</sub> = Stored Charge)	Q <sub>RR</sub>	Consult factory	μC <sub>S</sub>
<small>Note 1: T<sub>J</sub> 25°C. Note 2: T<sub>J</sub> 125°C. Note 3: T<sub>CASE</sub> 55°C, double side air cooled. Note 4: 180° conduction, 60Hz sine wave.                      Note 5: Test conditions: I<sub>DC</sub> R<sub>L</sub> = 12Ω. Note 6: Switching from V<sub>DRM</sub> ≤ 1000V Note 7: In addition to 0.2μF and 20Ω snubber circuit</small>			

## Thermal & Mechanical

Parameter	Symbol	Rating	Units
Operating Temperature Range	T <sub>J</sub>	-40° ~ 125°	°Celsius
Maximum Thermal resistance, Junction to Case <small>Notes: 1, 3, 5</small>	R <sub>th-J-C</sub>	0.015	°C/W
Maximum Thermal resistance, Case to Heat Sink <small>Notes: 1, 2, 3, 4, 5</small>	R <sub>th-C-hs</sub>	0.002	°C/W
Mounting Pressure		3600 ~ 4500 8000 ~ 10000	kg lb.
<small>Note 1: Recommended mounting pressure applied Note 2: Mounting surfaces flat and greased Note 3: Double side cooled                      Note 4: Case Temperature measured at aux., cathode Note 5: 180° on-state</small>			