

FEATURES

- STACKED METALLIZED POLYETHYLENE NAPHTHALATE (PEN) FILM
- STANDARD EIA 1206, 1210, 1913, 2416, 2820, 3022 AND 3925 SIZES
- WIDE TEMPERATURE RANGE UP TO +125°C*
- HIGH HEAT AND MOISTURE RESISTANT
- VERY STABLE TEMPERATURE, FREQUENCY AND VOLTAGE BIAS CHARACTERISTICS
- REFLOW SOLDERING ONLY
- TAPE AND REEL PACKAGING

**NSWC IS
RECOMMENDED
FOR NEW DESIGNS**



**RoHS
Compliant**

includes all homogeneous materials

*See Part Number System for Details

SPECIFICATIONS	Case Sizes						
	1206	1210	1913	2416	2820	3022	3925
Capacitance Range	0.001 ~ 0.0047μF	0.0056 ~ 0.01μF	0.012 ~ 0.082μF	0.1 ~ 0.15μF	0.18 ~ 0.33μF	0.39 ~ 0.47μF	0.56 ~ 1.0μF
Voltage Ratings	100Vdc						
Capacitance Tolerance	0.001 ~ 0.01μF 5% (J) only, 0.012 ~ 0.15μF 5% (J) or 10% (K), 0.18 ~ 1.0μF 10% (K) only						
Temperature Range	-55°C ~ +105°C (0.001μF ~ 0.01μF) -55°C ~ +125°C (0.012μF ~ 1.0μF with derating above +85°C)						
Dissipation factor (20°C)	1.0% max. @ 1KHz						
Insulation resistance (20°C)	3 Gigohms or 1000Ω/F whichever is lower						
Dielectric Withstanding Voltage	150% of Rated Voltage 60 Seconds						

ENVIRONMENTAL CHARACTERISTICS

Life Test At +105°C 1,000 Hours at 125% of Rated Voltage (125°C for 0.012μF ~ 1.0μF)	Capacitance Change	Within +1%/-6% of Initial Value	
	Dissipation Factor	1.1% Maximum	
	Insulation Resistance	1 Gigohm Minimum or 300Ω/F whichever is lower	
Resistance to Soldering Heat: +240°C Peak	Capacitance Change	Within ±5% for 0.012 ~ 1.0μF or ±3% for 0.001 ~ 0.01μF of initial value	
	Dissipation Factor	1.1% Max. for 0.012 ~ 1.0μF or 0.66% Max. for 0.001 ~ 0.01μF	
	Insulation Resistance	1 Gigohm Minimum or 300Ω/F whichever is lower	
Humidity Load Life (90% ~ 95% RH) (1) 1,000 Hours, +40°C 500 Hours for 0.012μF ~ 1.0μF (2) 500 Hours, +60°C for 0.001 ~ 0.01μF	Capacitance Change	(1) +8%/-5%	(2) ±10% of Initial Value
	Dissipation Factor	(1) 1.5% Max.	(2) 2.0% Max.
	Insulation Resistance	(1) 100 Megohm Min. or 30Ω/F (2) 10 Megohm Min. or 3Ω/F whichever is lower	
Solderability with 25% Wt Rosin-Methanol Flux	90% Minimum Coverage After 2.5 Second Dip Into 245°C Solder Pot		

RECOMMENDED LAND PATTERN (mm)

EIA Size	A	B	C
1206	1.8	3.6	1.4
1210	1.8	3.6	2.3
1913	2.6	6.6	3.0
2416	3.8	7.8	3.8
2820	4.5	9.0	4.6
3022	5.1	9.7	5.0
3925	7.2	11.9	5.7

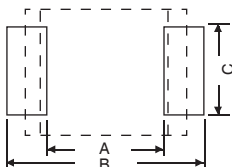

RECOMMENDED REFLOW PROFILE

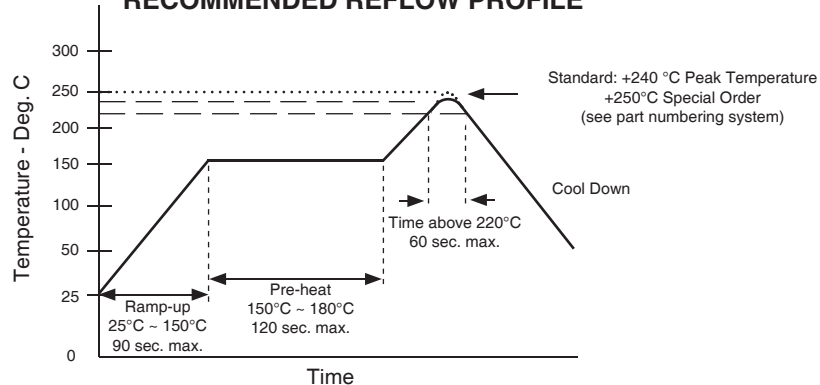

PART NUMBER SYSTEM

NSWC 823 J 100 TR D4 N E

- RoHS Compliant
- Optional High Temp. Reflow (+250°C)*
- Size Code
- Tape & Reel
- Voltage
- Tolerance Code: J = ±5%
- Capacitance in pF, 1st two digits are significant, 3rd digit is no. of zeros
- Series

*Special packaging and handling required.



100V STANDARD PRODUCTS AND CASE SIZES

Part Number	Cap. Value	Cap. Code	Size Code	Length L ±0.2	Width W	Height H ±0.2	p	EIA			
NSWC102J100TRB2F	0.001	102	B2	3.2 ± 0.2	1.6 ± 0.2	1.1 ± 0.3	0.65 ± 0.3 (Fig. 1)	1206			
NSWC122J100TRB2F	0.0012	122	B2								
NSWC152J100TRB2F	0.0015	152	B2								
NSWC182J100TRB2F	0.0018	182	B2								
NSWC222J100TRB2F	0.0022	222	B2			1.5 ± 0.3					
NSWC272J100TRB2F	0.0027	272	B2								
NSWC332J100TRB3F	0.0033	332	B3								
NSWC392J100TRB3F	0.0039	392	B3								
NSWC472J100TRB3F	0.0047	472	B3	3.2 ± 0.2	2.5 ± 0.2	1.5	1210				
NSWC562J100TRC2F	0.0056	562	C2								
NSWC682J100TRC2F	0.0068	682	C2								
NSWC822J100TRC3F	0.0082	822	C3								
NSWC103J100TRC3F	0.010	103	C3			2.1					
NSWC123*100TRD1F	0.012	123	D1								
NSWC153*100TRD1F	0.015	153	D1			4.8 ± 0.2		3.3 ± 0.3	1.4	1913	
NSWC183*100TRD1F	0.018	183	D1								
NSWC223*100TRD1F	0.022	223	D1								
NSWC273*100TRD1F	0.027	273	D1								
NSWC333*100TRD1F	0.033	333	D1								
NSWC393*100TRD1F	0.039	393	D1								
NSWC473*100TRD2F	0.047	473	D2								
NSWC563*100TRD2F	0.056	563	D2								
NSWC683*100TRD3F	0.068	683	D3								
NSWC823*100TRD4F	0.082	823	D4								
NSWC104*100TRE1F	0.1	104	E1	6.0 ± 0.2	4.1 ± 0.3		1.8		0.35 ± 0.2 (Fig. 2)		2416
NSWC124*100TRE3F	0.12	124	E3								
NSWC154*100TRE4F	0.15	154	E4								
NSWC184K100TRG1F	0.18	184	G1								
NSWC224K100TRG2F	0.22	224	G2	7.1 ± 0.2	5.0 ± 0.4		2.0		2820		
NSWC274K100TRG3F	0.27	274	G3								
NSWC334K100TRG5F	0.33	334	G5								
NSWC394K100TRQ1F	0.39	394	Q1								
NSWC474K100TRQ2F	0.47	474	Q2	7.7 ± 0.2	5.5 ± 0.4	3.4	3022				
NSWC564K100TRR1F	0.56	564	R1								
NSWC684K100TRR3F	0.68	684	R3	9.8 ± 0.2	6.3 ± 0.4	3.0	3925				
NSWC824K100TRR6F	0.82	824	R6								
NSWC105K100TRR8F	1.0	105	R8								

*These values available in J (±5%) or K (±10%) tolerance.

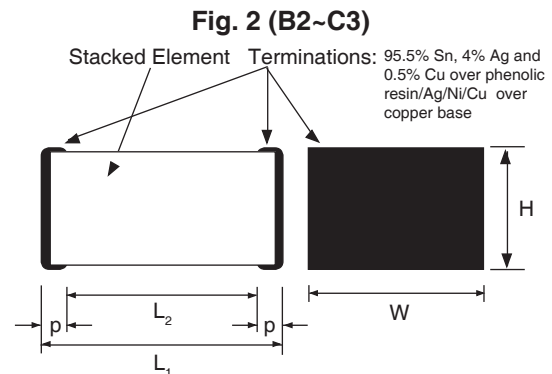
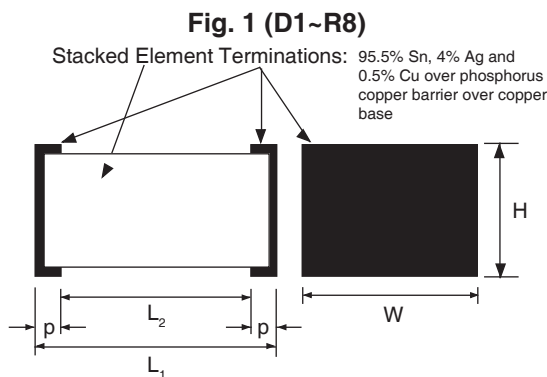

TAPE DIMENSIONS (mm)

Case Code	A±0.1	B±0.1	C±0.2	t	W±0.3	F	P±0.1	D+0.2/-0	Qty/Reel
B2	1.9	3.5	1.5	0.25	8.0	3.5	4.0	1.0	3,000
B3			1.9						2,000
C2	1.9		2,000						
C3	2.8	2.5	2,000						
D1	3.8	5.1	2.0	0.3 ±0.05	12.0	5.5 ±0.05	8.0	1.5	3,000
D2			2.6						3,000
D3, D4	3.4		2,000						
E1, E2	4.6	6.3	2.7	-	-	-	-	-	3,000
E3, E4			3.5						2,000
G1 ~ G5	5.5	7.4	4.7						1,500
Q1, Q2	6.91	8.43	5.685	0.343 ±0.013	16.0	7.5 ±0.1	12.0	1.5	1,000
R1 ~ R8	8.94	10.54	5.795	1,000					

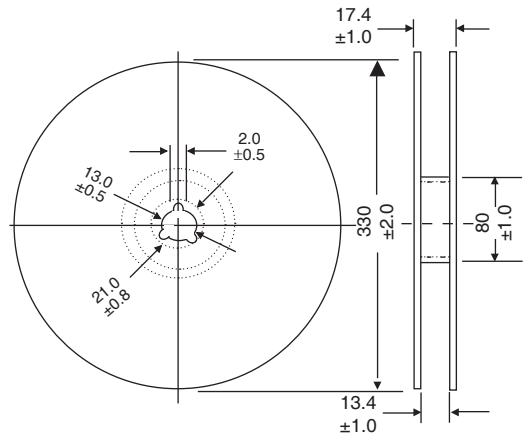

EMBOSSED PLASTIC CARRIER

