

FEATURES

- DOUBLE LAYER CONSTRUCTION
- HIGH TEMPERATURE REFLOW (+260°C)
- SURFACE MOUNTABLE V-CHIP STYLE
- EXTENDED TEMPERATURE RANGE (UP TO +85°C FOR NEZVL)

**RoHS
Compliant**
includes all homogeneous materials



CHARACTERISTICS

Series		NEZVN	NEZVL	
Operating Temperature Range		-25°C ~ +70°C	-40°C ~ +85°C	
Rated Capacitance Range		0.047F (47,000µF), 0.1F (100,000µF) and 0.22F (220,000µF)		
Capacitance Tolerance		+80%/-20% (Z)		
Rated Voltage Range		5.5VDC		
Load Life Test 1,000 hours	NEZVN @ +70°C NEZVL @ +85°C	Δ Capacitance Change	Less than ±30% of initial measured value	
		Maximum ESR	Less than 400% of the specified maximum value	
		Maximum Leakage Current	Less than 200% of the specified maximum value	
Characteristics at High & Low Temperature	NEZVN @ -25°C ~ +70°C	Δ Capacitance Change	Less than ±30% of 20°C value	
		Maximum ESR	Less than 500% of 20°C value	
		Maximum Leakage Current	Less than 400% of 20°C value	
	NEZVL @ -40°C ~ +85°C	Δ Capacitance Change	Less than ±30% of 20°C value	
		Maximum ESR	-40°C	Less than 700% of 20°C value
			-25°C/+85°C	Less than 500% of 20°C value
Maximum Leakage Current	Less than 400% of the specified maximum value			
Vibration 10 ~ 55Hz (1 min./sweep) Total Amplitude 1.5mm, 2Hr in XYZ Directon	Δ Capacitance Change		Less than ±10% of initial measured value	
	Maximum ESR		Less than initial specified maximum value	
	Maximum Leakage Current		Less than initial specified maximum value	
Resistance to Soldering Heat Peak Temp. +260°C (Time over +230°C <30 seconds)	Δ Capacitance Change		Less than ±10% of initial measured value	
	Maximum ESR		Less than initial specified maximum value	
	Maximum Leakage Current		Less than initial specified maximum value	

STANDARD VALUES AND SPECIFICATIONS

NIC P/N	Capacitance Value (F)	Working Voltage (VDC)	Holding Voltage (VDC min.)	Max. Leakage Current after 30 minutes (µA)	Max. ESR @ 1KHz (Ω)
NEZVN473Z5.5V12.5X8.5TRF	0.047	5.5	4.0	69	30
NEZVN104Z5.5V12.5X8.5TRF	0.1	5.5	4.0	100	30
NEZVN224Z5.5V12.5X8.5TRF	0.22	5.5	4.0	135	30
NEZVL473Z5.5V12.5X10.5TRF	0.047	5.5	4.0	69	45
NEZVL104Z5.5V12.5X10.5TRF	0.1	5.5	4.0	100	45
NEZVL224Z5.5V12.5X10.5TRF	0.22	5.5	4.0	135	45

CASE DIMENSIONS (mm)

Case Size	Dφ ± 0.5	L max.	A/B ±0.2	I	W	P
12.5X8.5	12.5	8.5	13.0	5.0	1.2	5.0
12.5X10.5	12.5	10.5	13.0	5.0	1.2	5.0

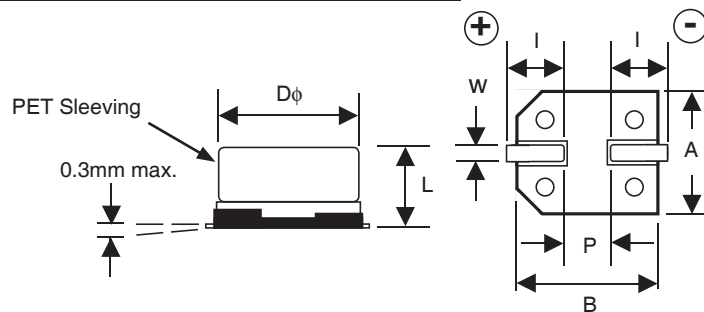

PRECAUTIONS

WASHING is NOT RECOMMENDED. Additional precautions can be found at www.niccomp.com/precautions
If in doubt or uncertainty, please review your specific application - process details with NIC's technical support personnel: tpmg@niccomp.com



LAND PATTERN DIMENSIONS (mm)

Case Diameter	R	S	T
12.5	4.0	6.0	3.2

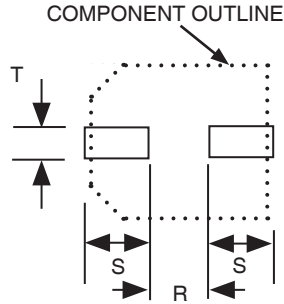

STANDARD RECOMMENDED REFLOW PROFILE

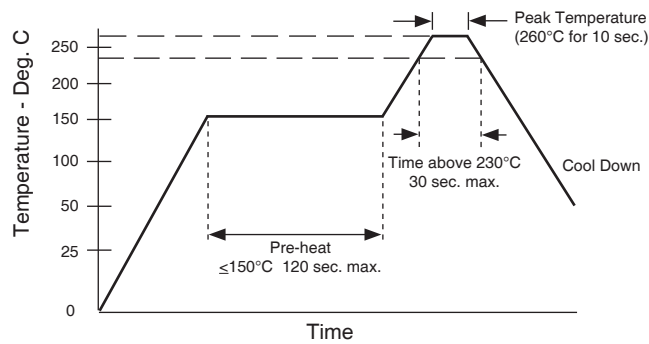

1. The temperatures shown are the surface temperature values on the top of the can and on the capacitor terminals.
2. 2x reflow process maximum. Capacitor should be allowed to return to room temperature before second reflow process.

PART NUMBER SYSTEM

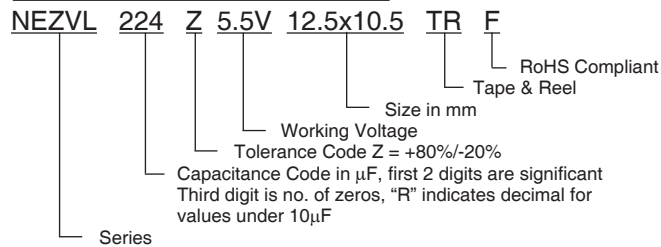

CARRIER TAPE DIMENSIONS (mm)

Case Size	A ± 0.2	B ± 0.2	D +1/-0	E ± 0.1	F ± 0.1	P ± 0.1	P ₁ ± 0.1	T ₁ ± 0.1	T ₂ ± 0.2	W ± 0.3	Quantity/Reel
12.5 x 8.5	13.4	13.4	1.50	1.75	11.5	4.0	24.0	0.5	9.5	32.0	300
12.5 x 10.5	11.4	13.0	1.50	1.75	11.5	4.0	24.0	0.5	11.0	32.0	250

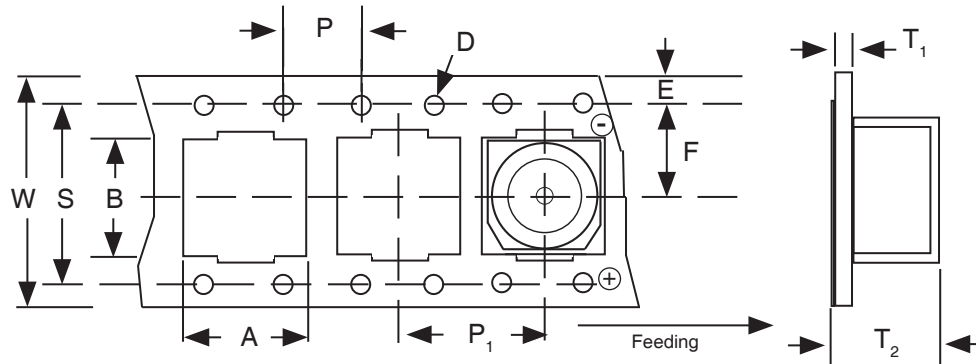

REEL DIMENSIONS (mm)

Case Diameter	A max.	B min.	C ± 0.5	W	t
12.5	φ322	φ80	13.0	32.0	3.0

