

SERIAL REAL TIME CLOCK/Calendar with 31 x 8 RAM

Applications:

Cash Registers

Security Access Controllers, Door Controllers

Time Recorders

IC Water-Flow Meters

IC Gas Meters

Mobile Telephones



Part Numbering Example: CS1302– Z3C

CS1302-	Z	3	C
SERIES	ADDED FEATURES	PACKAGE	OPERATING TEMP
CS1302	Z = Tapes & Reels	3 = 8DIP 4 = 8SOIC	C = 0 °C to +70 °C I = -40 °C to +85 °C

Specifications

- Real time clock counts seconds, minutes, hours, months, day of the week, and years with leap year compensation valid up to 2100
- 31 X 8 RAM for scratchpad data storage
- 2.0-5.5 volt full operation
- Uses less than 300 nA at 2.0 volts
- Single-byte or multiple-byte (burst mode) data transfer for read or write of clock or RAM data
- 8-pin DIP or optional 8-pin SOIC for surface mount
- Simple 3-wire interface
- TTL-compatible (VDD = 5V)
- Optional industrial temperature range -40 °C to +85 °C

General Description

The CS1302 Trickle Charge Timekeeping Chip contains a real time clock/calendar and 31 bytes of static RAM. It communicates with a microprocessor via a simple serial interface. The real time clock/calendar provides seconds, minutes, hours, day, date, month, and year information. The end of the month date is automatically adjusted for months with less than 31 days, including corrections for leap year. The clock operates in either the 24-hour or 12-hour format with an AM/PM indicator. In order to minimize the pin number, the CS1302 uses a serial DATA transmission method to interface with a microprocessor. Only three wires are required: (1) CE (Chip Enable), (2) DATA (Data line), and (3) SCLK (Serial clock). Data can be transferred to and from the clock/RAM 1 byte at a time or in a burst of up to 31 bytes. The CS1302 is designed to operate on very low power.



SERIAL REAL TIME CLOCK/Calendar with 31 x 8 RAM

Block Diagram and Pin Description

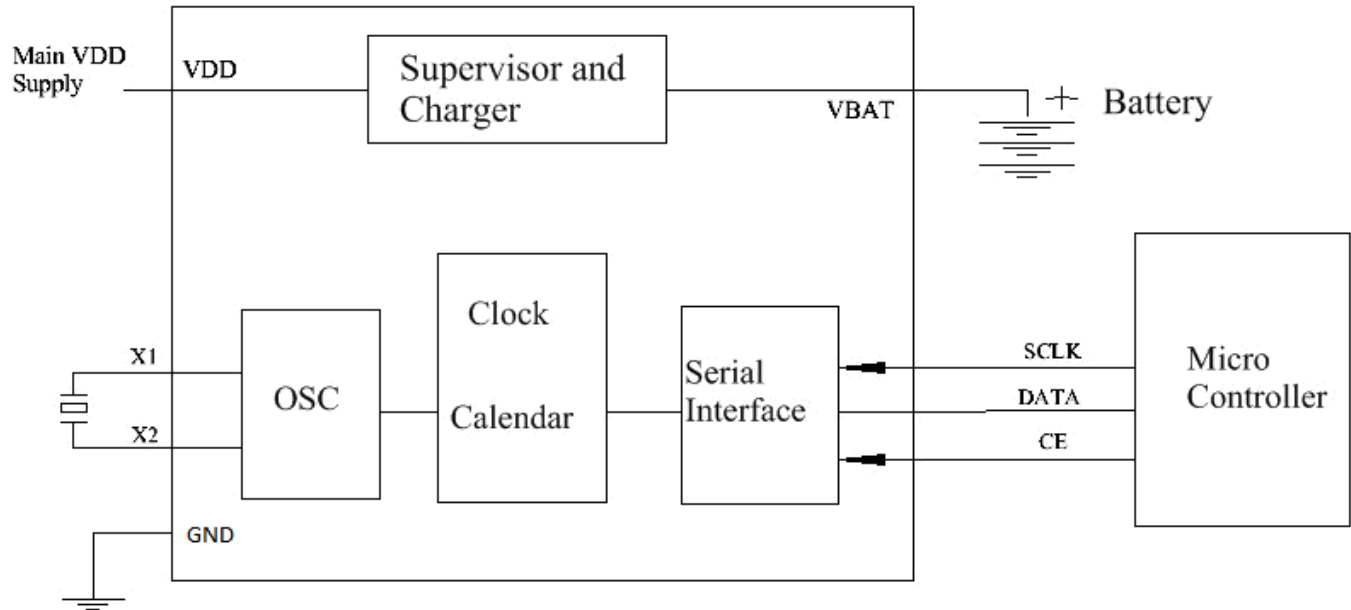

Figure 1. Block Diagram

Pin Description

Pin	Symbol	Description	Pin	Symbol	Description
1	VDD	The Primary Supply Pin	5	CE	Chip Enable
2	X1	32.768 kHz Crystal Pins	6	DATA	Data Input/Output
3	X2	32.768 kHz Crystal Pins	7	SCLK	Serial Clock
4	GND	Ground	8	VBAT	Backup Supply Pin

Absolute Maximum Ratings

Parameter	Symbol	Test Condition	Value	Unit
Voltage on Any Pin Relative to Ground	V _P		-0.5 ~ +7.0	V
Operating Temperature	T _A		0 ~ 70	°C
Storage Temperature	T _S		-55 ~ +125	°C
Soldering Temperature	T _H		260 (10sec)	°C

Note: This is a stress rating only and functional operation of the device at these or any other conditions above those indicated in the operation sections of this specification is not implied. Exposure to absolute maximum rating conditions for extended periods of time may affect reliability.

