



**The Cardinal Cappuccino Crystal Oscillator Voltage Controlled CMOS 10MHz - 250MHz**

**Features**

- 2.5V or 3.3V supply voltage-configurable
- 10MHz to 250MHz CMOS outputs-configurable
- Better than 2Hz tuning resolution
- Low power, typically 20mA CMOS
- Temperature range: -40°C to +85°C
- Stability: ± 25ppm
- APR: ±50ppm
- Phase Jitter (12kHz – 20MHz) .9ps RMS

**Applications**

- Multimedia
- Computing
- Networking, etc.

**Part Numbering Example: CJVA C 7P L Z - A7 BR - XXX.XXX TS**

CJVA	C	7P	L	Z	A7	BR	XXX.XXX	TS
SERIES	OUTPUT	PACKAGE STYLE	VOLTAGE	ADDED FEATURES	OPERATING TEMP.	STABILITY	FREQUENCY	TRI-STATE
CJVA	C = CMOS	5 = 5 X 3.2 Ceramic 7 = 5 X 7 Ceramic 5P = 5 X 3.2 Plastic 7P = 5 X 7 Plastic	S = 2.5V L = 3.3V	Z = Tape and Reel	A7 = -40°C to +85°C	BR = ± 25ppm BP = ± 50ppm		TS = Tri-State

**Specification**

Waveform	CMOS
Frequency	10MHz to 250MHz
Operating Temperature Range	-40°C to +85°C
Storage Temperature Range	-55°C to +125°C
Supply Voltage	2.5V, 3.3V
Frequency Stability vs. Temp. Range	±25ppm/ ±50ppm
Input Current	40mA
Rise/ Fall Time	4ns
Phase Jitter	.9ps Typical
Duty Cycle	48/52
Start-Up Time	10ms Max
Enable/ Disable Input Voltage	VIH ≥ 0.7VDD or No Connection, VIL ≤ 0.3VDD or Ground
Output Load	15pF
Aging/ Year	±3ppm Max



**Description**

The Cardinal Cappuccino crystal oscillator is based on a high performance integrated circuit designed for use in Cardinal’s continued expanding leadership products in the programmable frequency control industry. Cardinal’s new Cappuccino design is today state of the art in oscillators. The Cappuccino line product features 10MHz to 1.5GHz with CJVA ranging 10MHz to 250MHz Output, 2.5V or 3.3V Supply Voltage, CMOS commercial -20°C to +70°C and industrial temperature range -40°C to +85°C.

Cardinal’s new CJVA series is competitively priced and has the lowest typical power consumption 20mA CMOS (70% less power than the Fox XpressO™ oscillator), lowest jitter and best phase noise over 10kHz to 20MHz verses the traditional fixed frequency quartz oscillators and Surface Acoustic Wave oscillators. Cardinal’s programming centers utilize modern robotics, for testing, programming and 100% final testing as we do with all our programmable offerings. The Cardinal CJVA series line is offered in both ceramic and low cost plastic industry standard packages.

Cardinal’s Cappuccino line fits in all applications requiring a reference frequency including Multimedia, Computing, Networking, consumer etc.

**Absolute Maximum Ratings**

Item	Symbol	Condition	Unit
Input Voltage	V <sub>I</sub>	-0.5 to V <sub>DD</sub> + 0.5	V
Output Voltage	V <sub>O</sub>	-0.5 to V <sub>DD</sub> + 0.5	V
Positive Supply Voltage	V <sub>DD</sub>	4.2	V
Storage Temperature		-55 to +125	°C



**DC Electric Characteristics (T = 25°C)**

Unless stated otherwise, the data presented here was taken over the following parameters,  $V_{DD} = 3.3V \pm 10\%$  or  $2.5V \pm 5\%$ ,  $T_a = -40^\circ C$  to  $+85^\circ C$  (industrial)

Item		Symbol	Specification			
			Min	Typ	Max	Units
Power Supply ( $V_{DD}$ , GND pins)	Power Supply Voltage	$V_{DD}$	2.97	3.3	3.63	V
		$V_{DD}$	2.375	2.5	2.625	V
	CMOS $I_{DD}$	$I_{DD}$		20	40	mA
	Current w/Output Disabled	$I_{OED}$		16		mA
	Rise Time	$T_{VDD}$	100			$\mu S$
Output Enable Function OE Pin Input LVCMOS/ LVTTTL	Input High Voltage	$V_{IH}$	$0.7 * V_{DD}$			V
	Input Low Voltage	$V_{IL}$			$0.3 * V_{DD}$	V
	Input High Current	$I_{IH}$			5	$\mu A$
	Input Low Current	$I_{IL}$	-10			$\mu A$
	Equivalent Internal Pullup Resistance	$R_{PULLUP}$		900		$\kappa\Omega$
Vc pin	Input High Voltage ( $V_{DD} = 3.3V$ )	$V_{IH}$			$V_{DD} + .1 * V_{DD}$	V
	Absolute max Voltage ( $V_{DD} = 3.3V$ )				4	V
	Input High Voltage ( $V_{DD} = 2.5V$ )				$V_{DD} + .05 * V_{DD}$	V
	Input Low Voltage	$V_{IL}$	-0.3			V
	Input High Current	$I_{IH}$			5	$\mu A$
	Input Low Current	$I_{IL}$	-5			$\mu A$
	Input Impedance			1		$M\Omega$
	Vc Bandwidth		10			kHz
Vc Pull		-100		100	ppm	



Item	Symbol	Specification				
		Min	Typ	Max	Units	
<b>AC Characteristics</b>						
<b>Outputs</b>						
LVCMOS/ LVTTTL (Out)	Frequency Range	$F_{CMOS}$	10		250	MHz
	Stability		-25		+25	ppm
	Operating Temperature		-40		+85	°C
	Output High Voltage	$V_{OH}$	$.9 \cdot V_{DD}$			V
	Output Low Voltage	$V_{OL}$			$.1 \cdot V_{DD}$	V
	Duty Cycle	$ODC_{CMOS}$	45		55	%
	Rise Time	$t_R$	300		600	ps
	Fall Time	$t_F$	300		600	ps
OE Turn On Time ( $<50MHz$ )		$OE_{LOW/HIGH}$			200	ns
OE Turn On Time ( $>50MHz$ )		$OE_{LOW/HIGH}$			100	ns
OE Turn Off Time		$OE_{HIGH/LOW}$			50	ns
Jitter	Phase Jitter (12kHz to 20MHz)	tjit	0.4	0.9	1.5	ps rms
	Period Jitter	$t_{RMS, CMOS}$		3	4.5	ps
		$t_{p-p, CMOS}$			30	45

Performance Characteristic Curves

Unless otherwise specified, data is characterized over temperature range -40°C to +85°C and voltage range 2.2V - 3.63V.

$I_{DD}$  vs.  $V_{DD}$

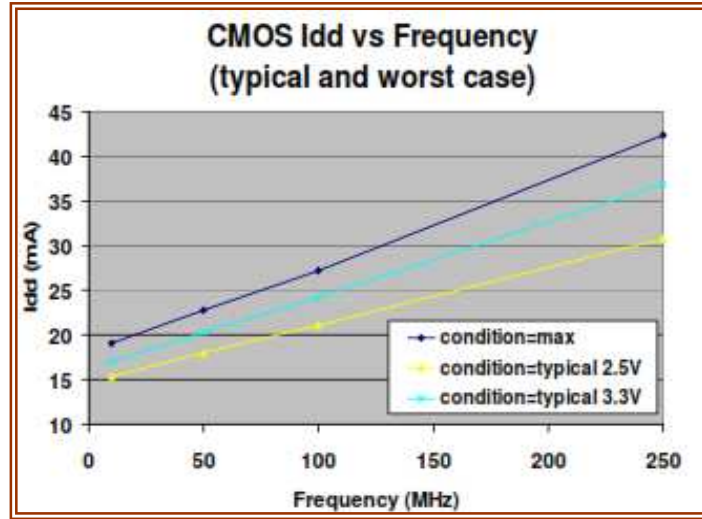
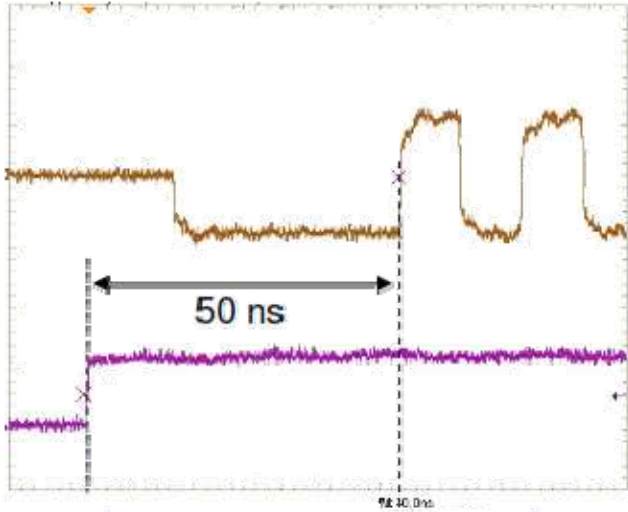

Figure 1. CMOS  $I_{DD}$  vs. Frequency,  $V_{DD}$

**OE Turn-on and Turn-off Times**

Notes:

- These measurements were all performed with an AC coupled output so that leakage currents do not affect the timing of the measurement. This results in all outputs floating to the midpoint of the signal levels when off.
- When CMOS is disabled the output goes to a Tri-State level.



**Figure 2. 2.5V CMOS OE Enabled Time**

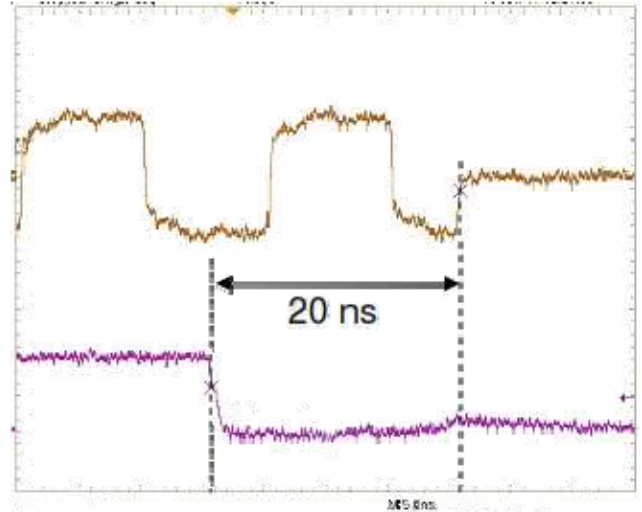

**Figure 3. 2.5V CMOS OE Disabled Time**

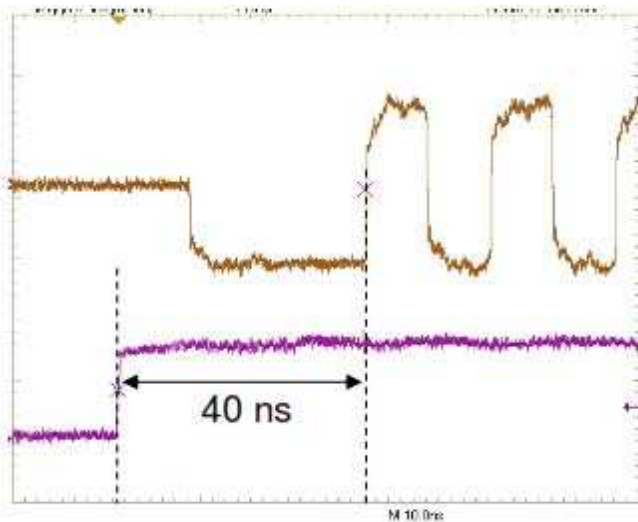

**Figure 4. 3.3V CMOS OE Enabled Time**

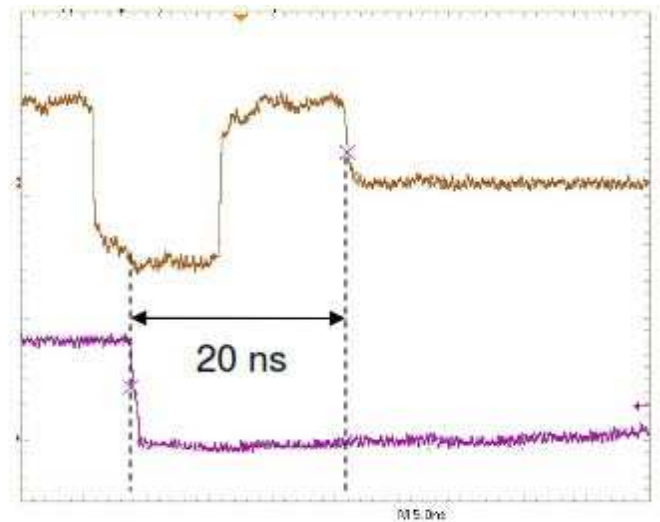

**Figure 5. 3.3V CMOS OE Disabled Time**

**Waveform Measurements**

The following figures are descriptions for how the waveforms are measured for the datasheet applications.

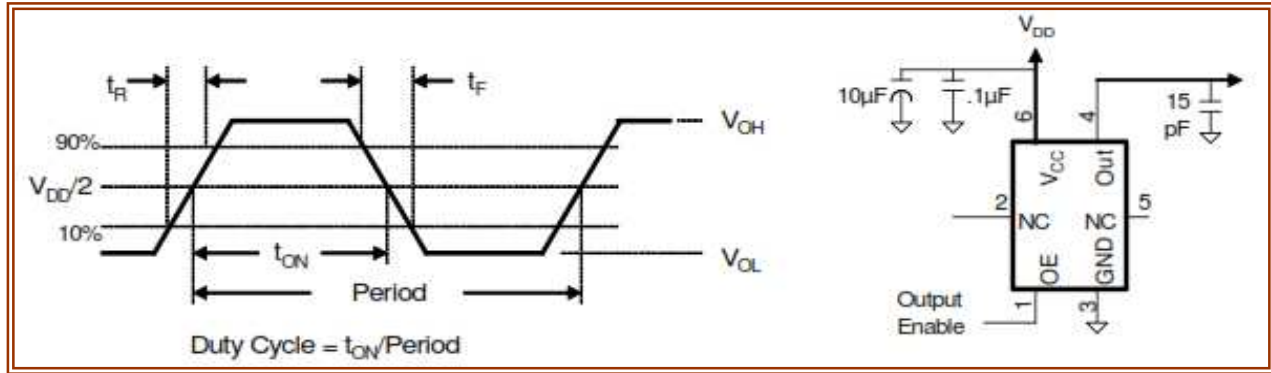

**Figure 6.** CMOS waveform measurement test setup

**Application Information**

Termination for LVCMOS Output

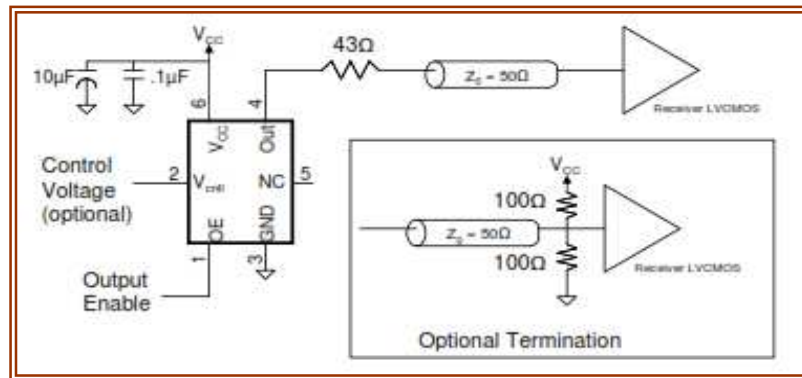
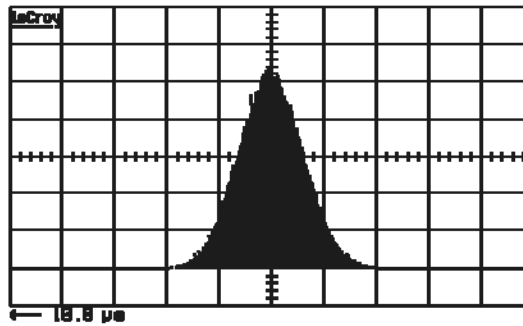

**Figure 7.** LVCMOS XO Application Schematic & Power Supply Decoupling

## Phase Noise & Jitter Plots

11-Feb-13  
22:46:11

0:Hp0lv(2)  
5 ps  
298 #  
←8X/98X  
in 155488



p0lv(2) 8.438 ns  
low(D) 1 8.41417 ns  
high(D) 1 8.44472 ns  
range(D) 1 38.258 ps  
signs(D) 1 3.854 ps

1 ps  
1 trig only  
83m 800 g  
d disabled  
4 trig only

2 UC -13mW

SING. CLOCK

Select  
Measurement  
View

acquire mode  
Single

acquire  
18.88 ps

ACQUISITION

0 00%

STOPPED

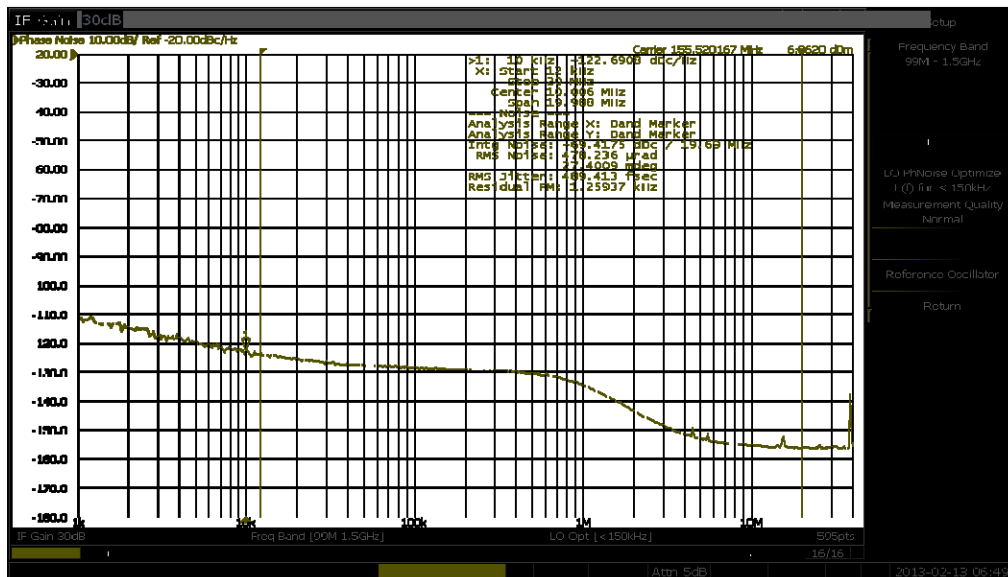
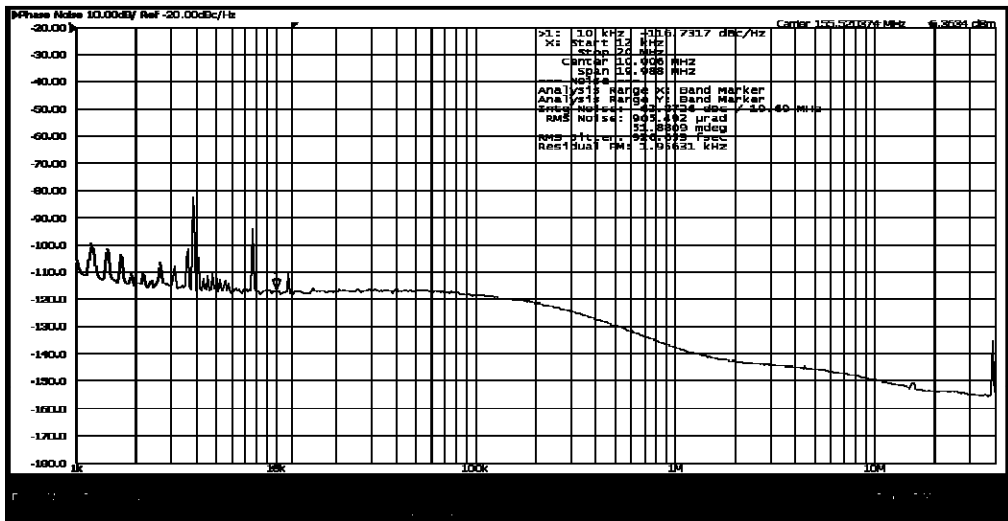

145 Route 46 West  
Wayne, NJ 07470

Recommended Solder Profile for  
 Cardinal Components, Inc.  
 Package Infrared Reflow.  
 Do Not Use Ultrasonic-Wave Soldering or  
 Wave Solder with Package Immersed in Solder  
 Damage to Crystal will result.

**Temperature (Deg. °)**

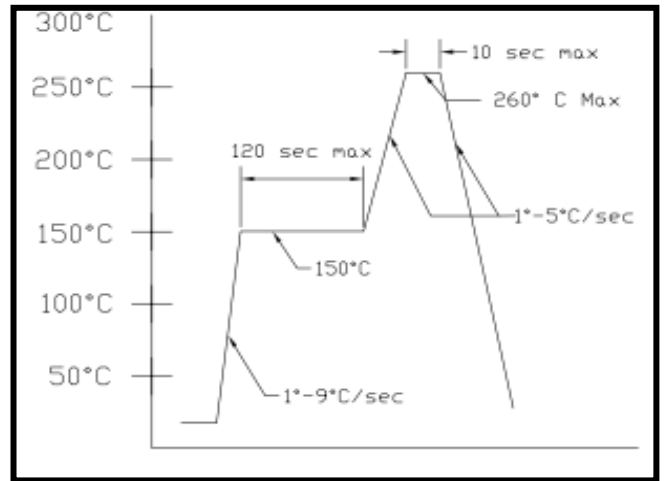

**Time (sec)**

**Reliability**

Cardinal Components Inc., qualification includes aging at various extreme temperatures, shocks and vibration, temperature cycling, and IR reflow simulation. The Cappuccino family meets the following qualification tests:

Environmental Compliance	
Parameter	Conditions
Mechanical Shock	MIL-STD-883, Method 2002
Mechanical Vibration	MIL-STD-883, Method 2007
Solderability	MIL-STD-883, Method 2003
Gross and Fine Leak	MIL-STD-883, Method 1014
Resistance to Solvents	MIL-STD-883, Method 2016
Moisture Sensitivity Level	IPC/ JEDEC J-STD-020, MSL1

**Handling Precautions**

Although ESD protection circuitry has been designed into the Cappuccino proper precautions should be taken when handling and mounting. Cardinal employs a human body model (HBM) and a charged-device model (CDM) for ESD susceptibility testing and design protection evaluation.

ESD Ratings		
Model	Minimum	Conditions
Human Body Model	1000V	MIL-STD-883, Method 3015
Charged Device Model	900V	JEDEC, JESD22-C101
Machine Model	200V	JEDEC, JESD22-A115-A



145 Route 46 West  
 Wayne, NJ 07470

Tel: (973)785-1333  
 Fax: (973)785-0053  
 E-Mail: sales@cardinalxtal.com  
 Web: www.cardinalxtal.com

**Style 7: 5x7mm Ceramic**

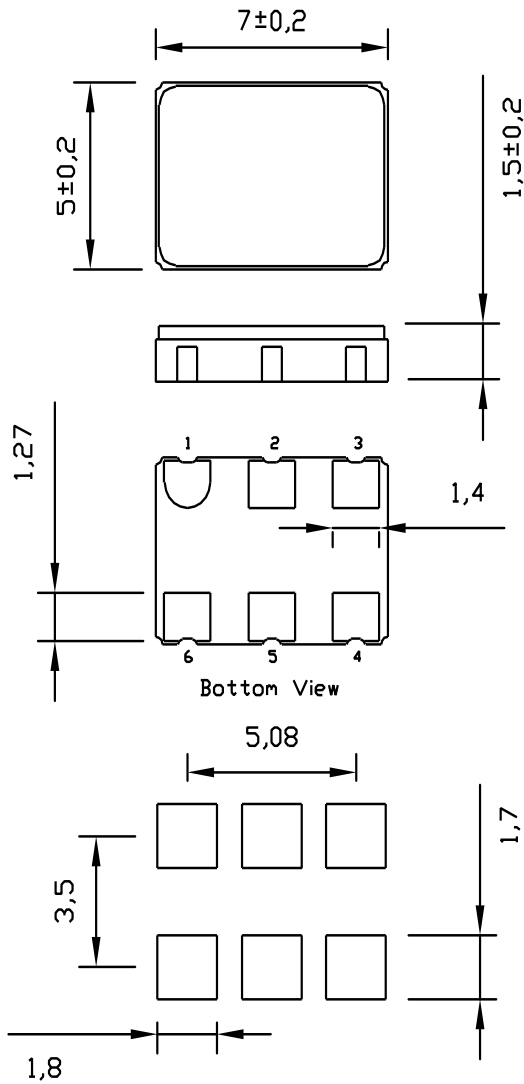

**Style 5: 5x3.2mm Ceramic**

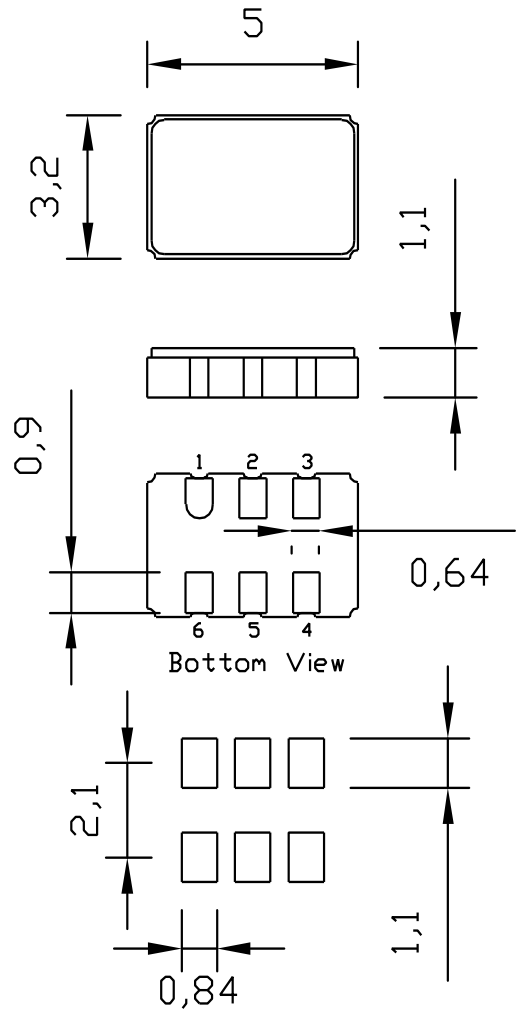

**6 Pad CMOS**

Pin 1	VS
Pin 2	OE
Pin 3	GND
Pin 4	Out
Pin 5	Do Not Connect
Pin 6	V <sub>DD</sub>

**6 Pad CMOS**

Pin 1	VC
Pin 2	OE
Pin 3	GND
Pin 4	Out
Pin 5	Do Not Connect
Pin 6	V <sub>DD</sub>

**Style 7P: 5x7mm Plastic**

**Style 5P: 5x3.2mm Plastic**

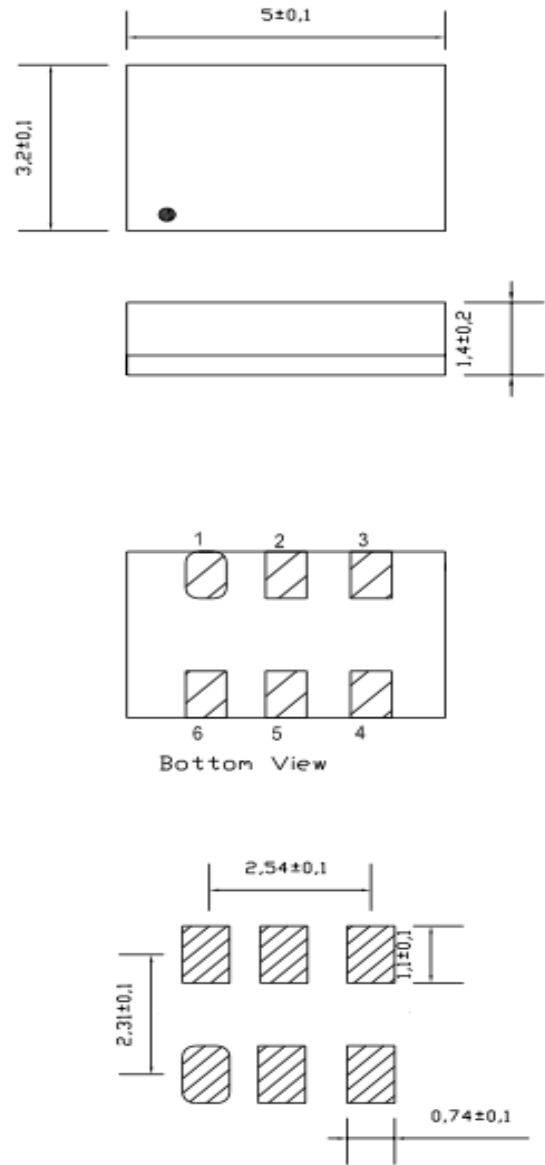
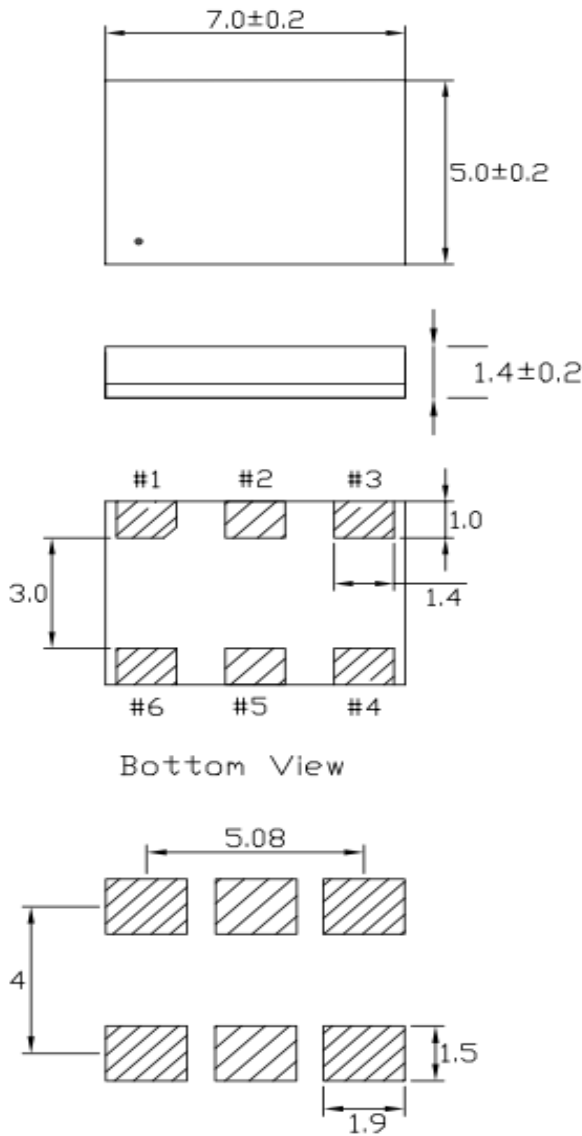

<b>6 Pad CMOS</b>	
Pin 1	VS
Pin 2	OE
Pin 3	GND
Pin 4	Out
Pin 5	Do Not Connect
Pin 6	V <sub>DD</sub>

<b>6 Pad CMOS</b>	
Pin 1	VC
Pin 2	OE
Pin 3	GND
Pin 4	Out
Pin 5	Do Not Connect
Pin 6	V <sub>DD</sub>

**Tape and Reel Specifications**

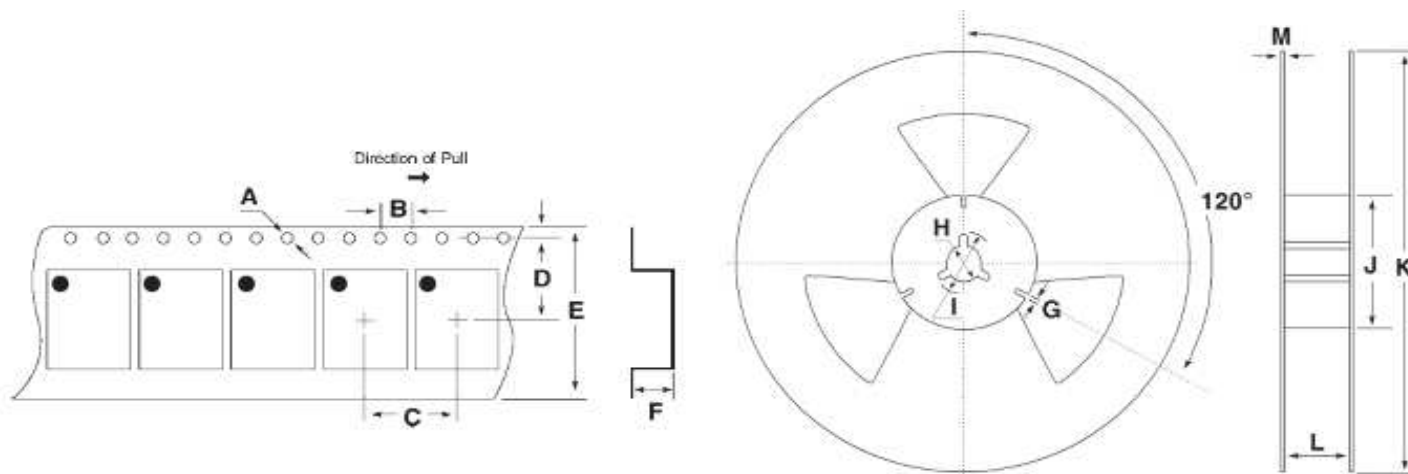

**Tape Specifications (mm)**

Model	A	B	C	D	E	F	STD QTY *
<b>CJVA</b>	1.5	4.0	8.0	9	16.0	1.8	1,000

**Reel Specifications (mm)**

Model	G	H	I	J	K	L	M
<b>CJVA</b>	2.0	13	21	60	180	17.5	1.0



145 Route 46 West  
Wayne, NJ 07470

Tel: (973)785-1333  
Fax: (973)785-0053  
E-Mail: [sales@cardinalxtal.com](mailto:sales@cardinalxtal.com)  
Web: [www.cardinalxtal.com](http://www.cardinalxtal.com)