

REV.	DESCRIPTION	DATE	APPROVED
A	Engineering Update w/o Changes	02/27/04	M. C.
B	0.027" Lead Hole Specification Update.	10/25/04	M. C.
C	0.020" Lead Hole Specification Update.	07/18/05	M. C.

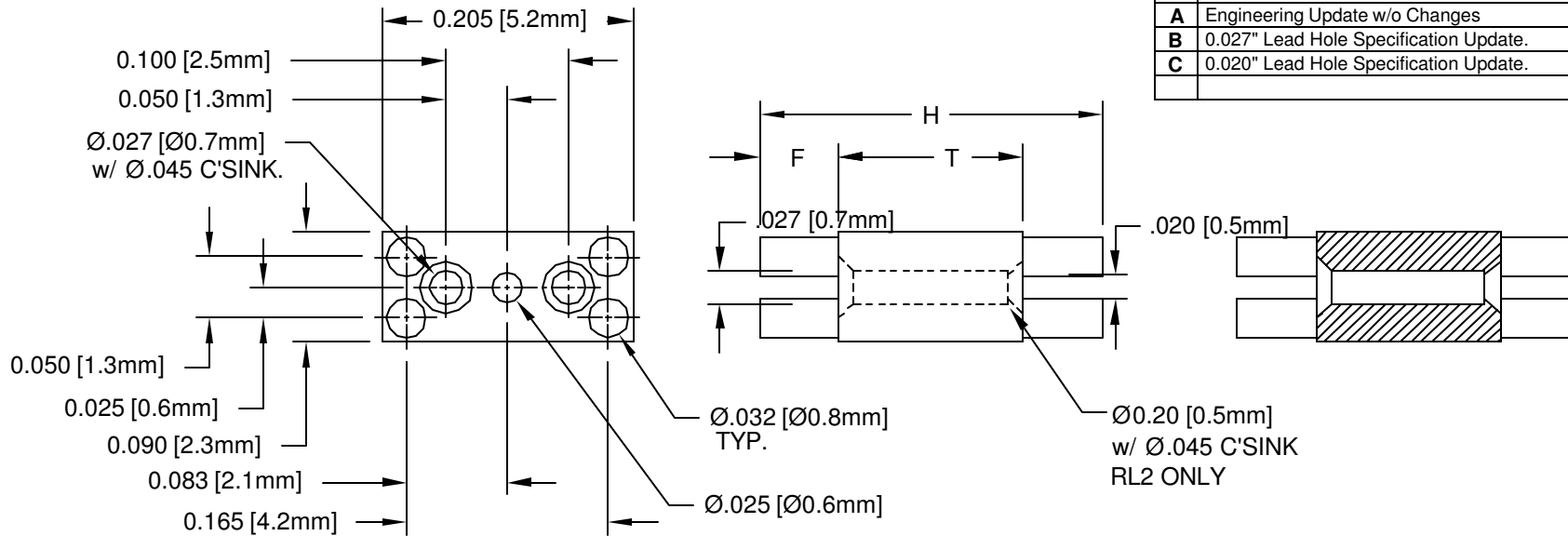

PART NUMBER	H	T	F
RL1-060	.060 (1.5mm)	0.040 (1.0mm)	0.010 (.25mm)
RL1-070	.070 (1.8mm)		0.015 (.38mm)
RL1-080	.080 (2.0mm)		0.020 (.51mm)
RL1-090	.090 (2.3mm)		0.025 (.64mm)
RL1-100	.100 (2.5mm)		0.030 (.76mm)
RL1-110	.110 (2.8mm)		0.035 (.89mm)
RL1-120	.120 (3.0mm)		0.040 (1.0mm)
RL1-130	.130 (3.3mm)		0.045 (1.1mm)
RL1-140	.140 (3.6mm)		0.050 (1.3mm)
RL1-150	.150 (3.8mm)		0.055 (1.4mm)
RL1-160	.160 (4.1mm)		0.060 (1.5mm)
RL1-170	.170 (4.3mm)		0.065 (1.7mm)
RL1-180	.180 (4.6mm)		0.070 (1.8mm)
RL1-190	.190 (4.8mm)		0.075 (1.9mm)
RL1-200	.200 (5.1mm)		0.080 (2.0mm)
RL1-210	.210 (5.3mm)		0.085 (2.2mm)

PART NUMBER	H	T	F
RL2-200	0.200 (5.1mm)	0.150 (3.8mm)	0.025 (.64mm)
RL2-210	0.210 (5.3mm)		0.030 (.76mm)
RL2-220	0.220 (5.6mm)		0.035 (.89mm)
RL2-230	0.230 (5.8mm)		0.040 (1.0mm)
RL2-240	0.240 (6.1mm)		0.045 (1.1mm)
RL2-250	0.250 (6.4mm)		0.050 (1.3mm)
RL2-260	0.260 (6.6mm)		0.055 (1.4mm)
RL2-270	0.270 (6.9mm)		0.060 (1.5mm)
RL2-280	0.280 (7.1mm)		0.065 (1.7mm)
RL2-290	0.290 (7.4mm)		0.070 (1.8mm)
RL2-300	0.300 (7.6mm)		0.075 (1.9mm)
RL2-310	0.310 (7.9mm)		0.080 (2.0mm)
RL2-320	0.320 (8.1mm)		0.085 (2.2mm)
RL2-330	0.330 (8.4mm)		0.090 (2.3mm)
RL2-340	0.340 (8.6mm)		0.095 (2.4mm)
RL2-350	0.350 (8.9mm)		0.100 (2.5mm)

2. MATERIAL: NYLON 6/6, 94V-0, NATURAL/WHITE. BIVAR MATERIAL CODE 24-WE.  
RTP POLYAMIDE NYLON 6/6, 0299X63548, NATURAL OR MODIFIED PLASTICS MN6/6-SE WHT.
1. GENERAL SPECIFICATIONS: BIVAR MOLDED COMPONENT SPECIFICATION BV00-E101.

STANDARD TOLERANCE ( UNLESS OTHERWISE SPECIFIED )	
DECIMALS	ANGULAR
.X ± .1	X° ± 1°
.XX ± .01	
.XXX ± .005	



DESIGNED: <b>Michael Chen</b>	DATE: <b>03/11/03</b>
CHECKED: <b>D. Green</b>	DATE: <b>03/11/03</b>



4 THOMAS, IRVINE, CA 92618  
TEL: (949) 951-8808 FAX: (949) 951-3974

TITLE: MOLDED RECTANGULAR LED MOUNT	
PART NO: RL1-RL2-XXX	REVISION: C
CAGE CODE : 32559	SHEET # 1 OF 1
CAD GENERATED DOCUMENT. DO NOT MEASURE DRAWING.	