

REV.	DESCRIPTION	DATE	APPROVED
C	Engineering Update w/o Changes	03/08/04	M. C.

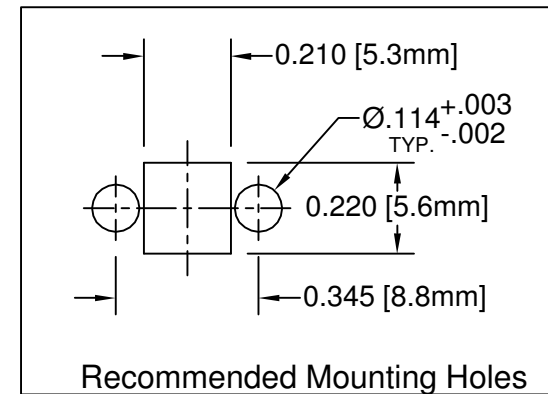
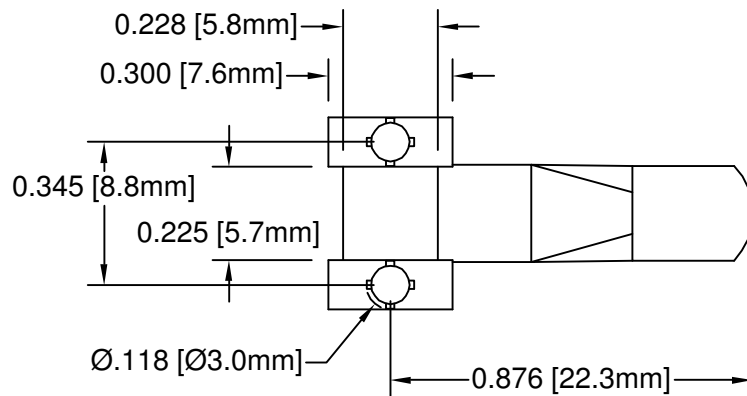
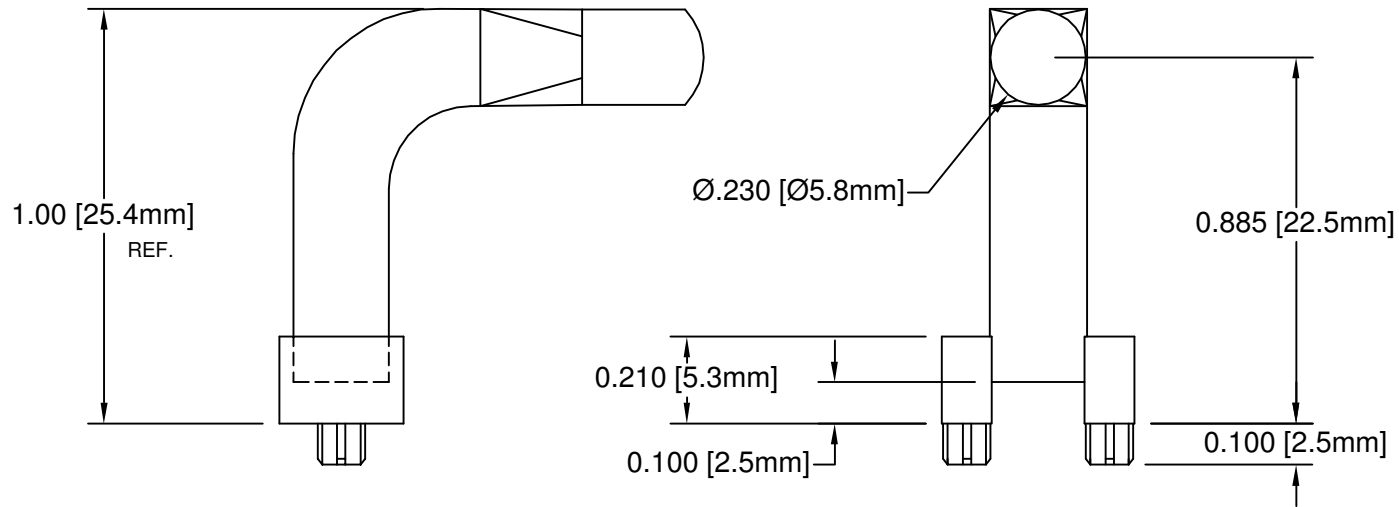

- MATERIAL: POLYCARBONATE 94V-0 CLEAR, BIVAR MATERIAL CODE 47-CR.
SAMYANG CORPORATION POLYCARBONATE 3025N2 CLEAR
- GENERAL SPECIFICATIONS: BIVAR MOLDED COMPONENT SPECIFICATION BV00-E101.

STANDARD TOLERANCE (UNLESS OTHERWISE SPECIFIED)		BIVAR [®]	
DECIMALS	ANGULAR	4 THOMAS, IRVINE, CA. 92618	
.X ± .1	X° ± 1°	TEL: (949) 951-8808 FAX: (949) 951-3974	
.XX ± .01		TITLE: LIGHT PIPE, 90° SURFACE MOUNT	
.XXX ± .005		PART NO: LP5-1000	
		REVISION: C	
DESIGNED: Shane Irving	DATE: 06/12/00	CAGE CODE : 32559 SHEET # 1 OF 1	
CHECKED: M. Chen	DATE: 07/23/01	CAD GENERATED DOCUMENT, DO NOT MEASURE DRAWING.	