

REV.	DESCRIPTION	DATE	APPROVED
D	Engineering Release.	05/31/13	T. Y.

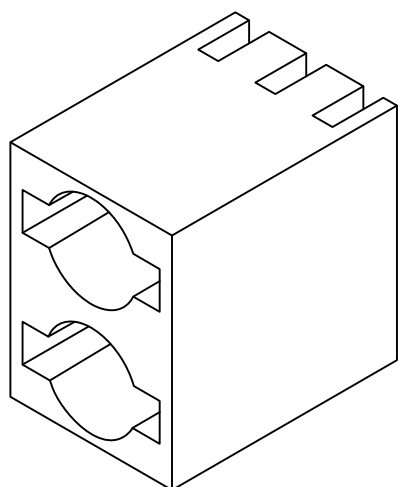
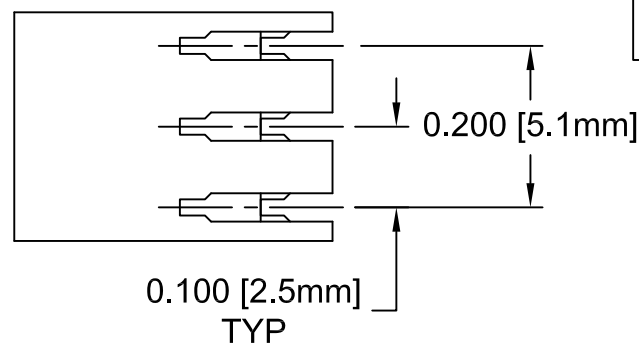
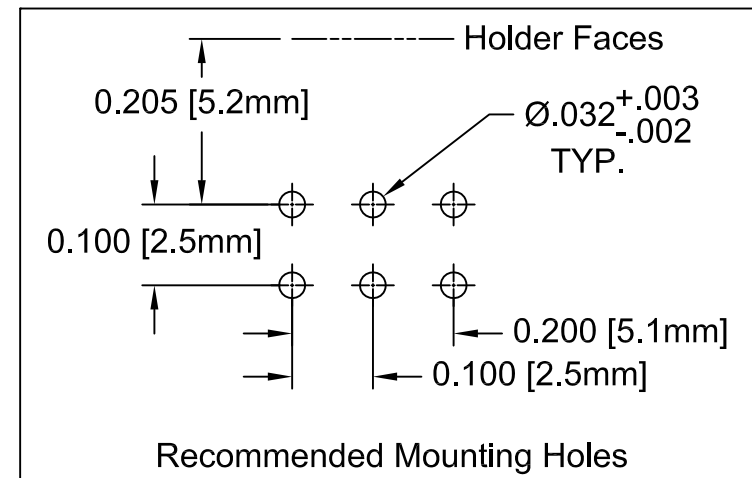
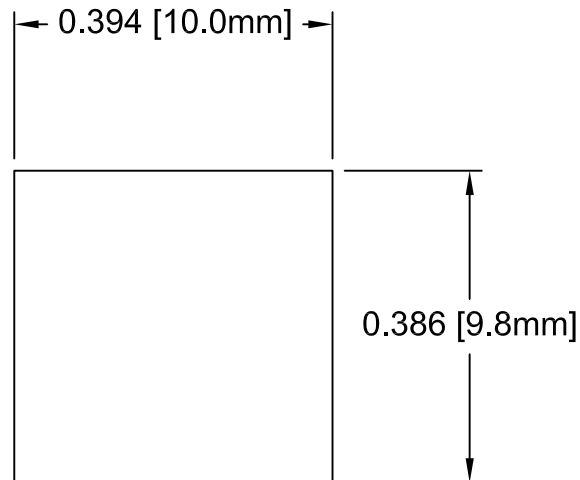
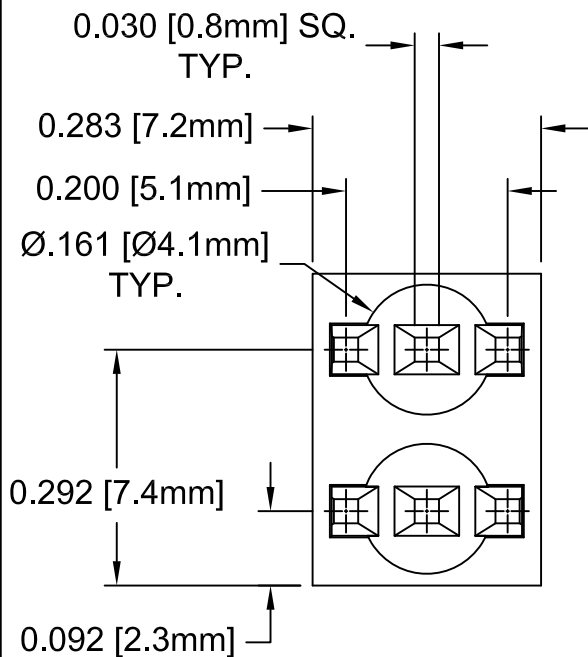

- 2. MATERIAL: NYLON 6/6, 94V-0, BLACK. BIVAR MATERIAL CODE 22-BK.
- 1. GENERAL SPECIFICATIONS: BIVAR MOLDED COMPONENT SPECIFICATION BV00-E101.

STANDARD TOLERANCE (UNLESS OTHERWISE SPECIFIED)		BIVAR [®] 4 THOMAS, IRVINE, CA. 92618 TEL: (949) 951-8808 FAX: (949) 951-3974	
DECIMALS	ANGULAR		
.X ± .1	X° ± 1°	TITLE: BI-LEVEL T1 (3mm) TRI LEAD LED HOLDER PART NO: H-280C REVISION: D	
.XX ± .01			
.XXX ± .005			
DESIGNED: Shane Irving	DATE: 02/16/99	CAGE CODE : 32559	SHEET # 1 OF 1
CHECKED: M. Chen	DATE: 03/06/03	CAD GENERATED DOCUMENT. DO NOT MEASURE DRAWING.	