

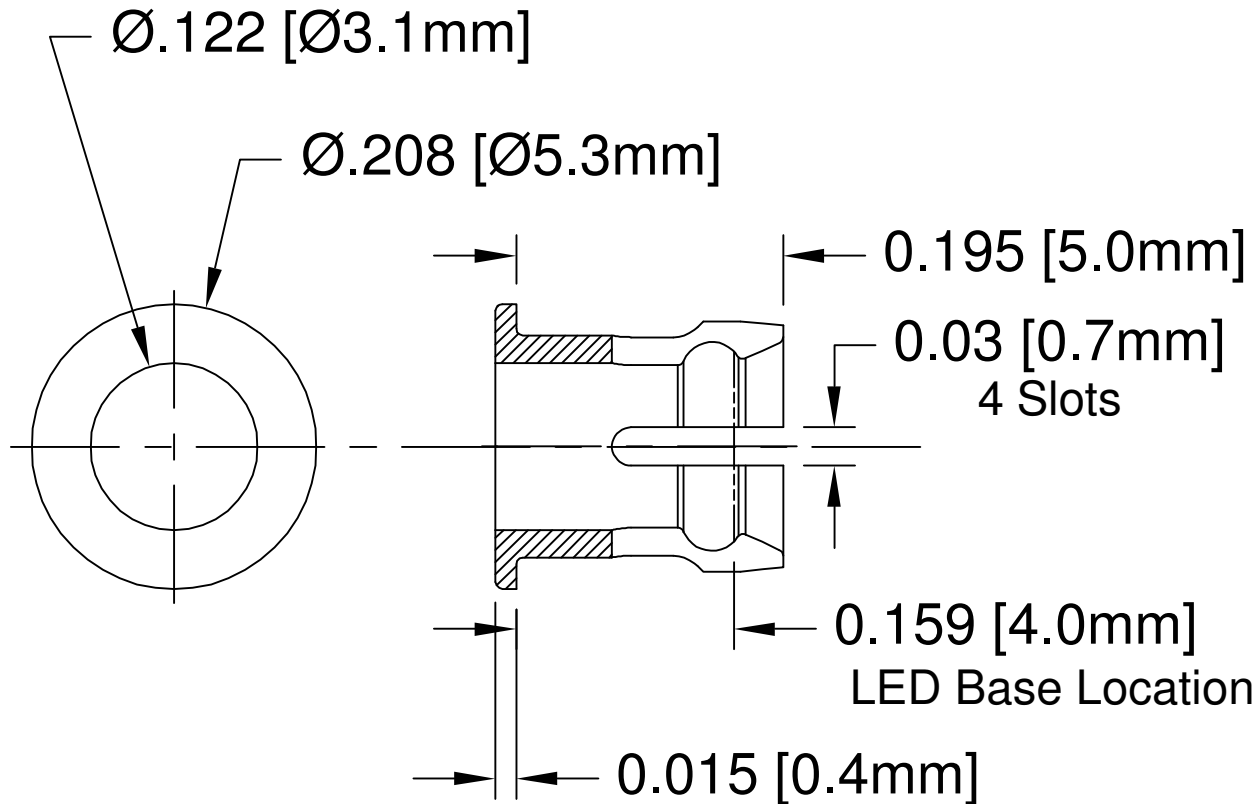

REV.	DESCRIPTION	DATE	APPROVED
A	Engineering Release	11/11/02	M. C.
B	Engineering Update w/o Changes	06/14/04	M. C.



3. MATERIAL: NYLON 6/6, 94V-0, BLACK. BIVAR MATERIAL CODE 22-BK.
RTP POLYAMIDE NYLON 6/6, 0200 FR, BLACK OR MODIFIED PLASTICS MN6/6-SE BK.
2. MATERIAL: NYLON 6/6, 94V-2, BLACK. BIVAR MATERIAL CODE 21-NL-BK.
TICONA NYLON 1310, NYLON 6/6, BLACK.
1. GENERAL SPECIFICATIONS: BIVAR MOLDED COMPONENT SPECIFICATION BV00-E101.

STANDARD TOLERANCE (UNLESS OTHERWISE SPECIFIED)		 4 THOMAS, IRVINE, CA. 92618 TEL: (949) 951-8808 FAX: (949) 951-3974	
DECIMALS	ANGULAR	TITLE: T-1 (3mm) LED CLIP	
.X ±.1	X° ± 1°		
.XX ±.01			
.XXX ±.005		DESIGNED: David Green	
		DATE: 11/11/02	
		REVISION: B	
CHECKED: M. Chen		DATE: 11/11/02	
		PART NO: C-104	
		CAGE CODE : 32559	
		SHEET # 1 OF 1	
CAD GENERATED DOCUMENT, DO NOT MEASURE DRAWING.			