

REV.	DESCRIPTION	DATE	APPROVED
A	Engineering Update w/o Changes	02/23/04	M. C.

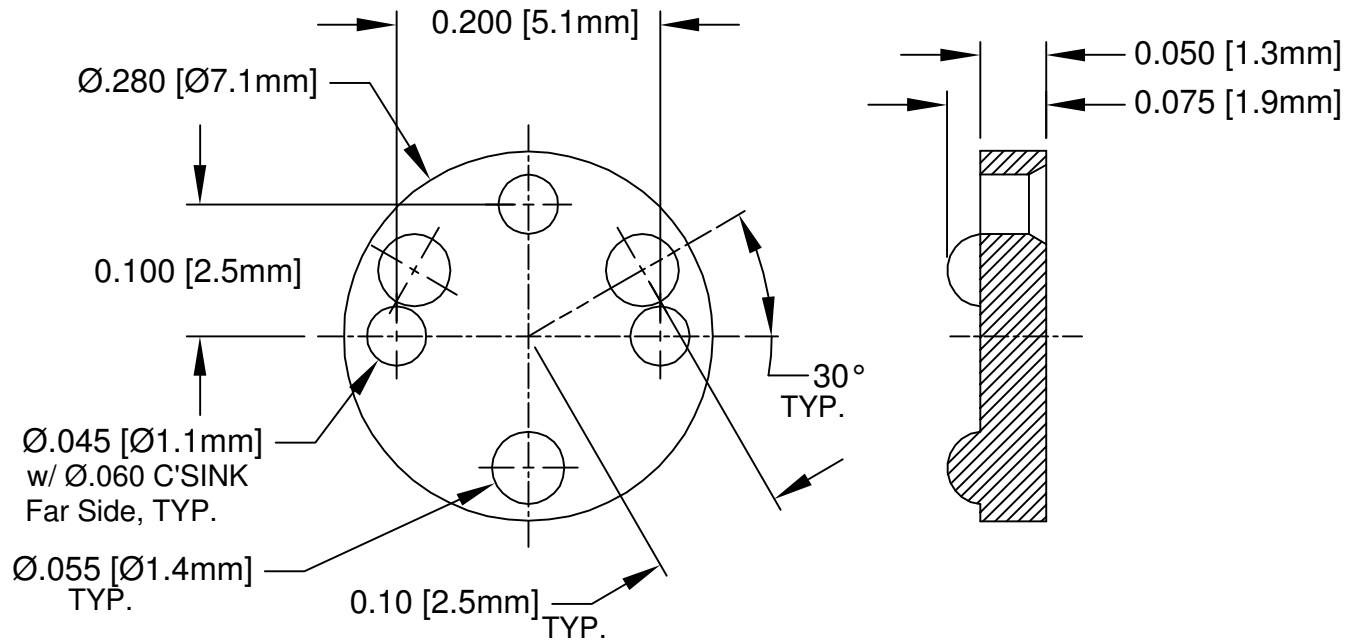

2. MATERIAL: NYLON 6/6, 94V-2, WHITE. BIVAR MATERIAL CODE 04-WE.
BASF ULTRAMID NYLON 6/6 A3K WHITE.
1. GENERAL SPECIFICATIONS: BIVAR MOLDED COMPONENT SPECIFICATION BV00-E101.

STANDARD TOLERANCE (UNLESS OTHERWISE SPECIFIED)		BIVAR® 4 THOMAS, IRVINE, CA. 92618 TEL: (949) 951-8808 FAX: (949) 951-3974	
DECIMALS	ANGULAR	TITLE: PERM-O-PAD TO-5 MOUNT	
.X ± .1	X° ± 1°		
.XX ± .01			
.XXX ± .005		DESIGNED: Shane Irving DATE: 06/23/98	
		PART NO: 508-075 REVISION: A	
		CHECKED: D. Green DATE: 02/23/04	
		CAGE CODE : 32559 SHEET # 1 OF 1	
CAD GENERATED DOCUMENT, DO NOT MEASURE DRAWING.			