

# 3mm (T1) Package Discrete LED GREEN, Low Current



## 3PGDL-X

- ◆ Industry Standard 3mm (T1) Package
- ◆ RoHS Compliant
- ◆ Diffused Lens
- ◆ Available in Flange (F), Standard (Blank), and Shouldered (S) Lead Frame styles
- ◆ 2 mA Low Operating Current
- ◆ Ideal for Status Indication and Display

Bivar 3mm T1 Package 2 mA Low Current LED is special binned at 2 mA and is ideal for those applications where lower power budget is required such as solar panel or battery-powered portable devices. Bivar offers diffused LED lens for uniform light output. The Flanged LED is ideal for Panel Mount Clip & Ring assemblies, the Standard Lead frame LED is ideal for vertical spacer assemblies without lead bends, and the Shouldered Lead frame LED has a built in strain relief feature which is ideal for Right Angle Holder assemblies that require lead bends. A long lead version is also available with a “-LL” suffix added to the part numbers.

Part Number	Material	Emitted Color	Peak. Wavelength $\lambda_p$ (nm) TYP.	Lens Appearance	Viewing Angle
3PGDL-F	GaP/GaP	GREEN	555nm	Green Diffused	35°
3PGDL				Green Diffused	40°
3PGDL-S				Green Diffused	40°

## Part Number Designation

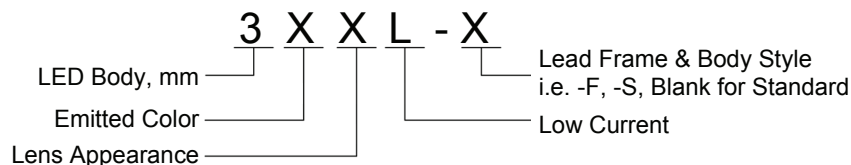

Bivar reserves the right to make changes at any time without notice.

# 3mm (T1) Package Discrete LED GREEN, Low Current



## Outline Dimensions

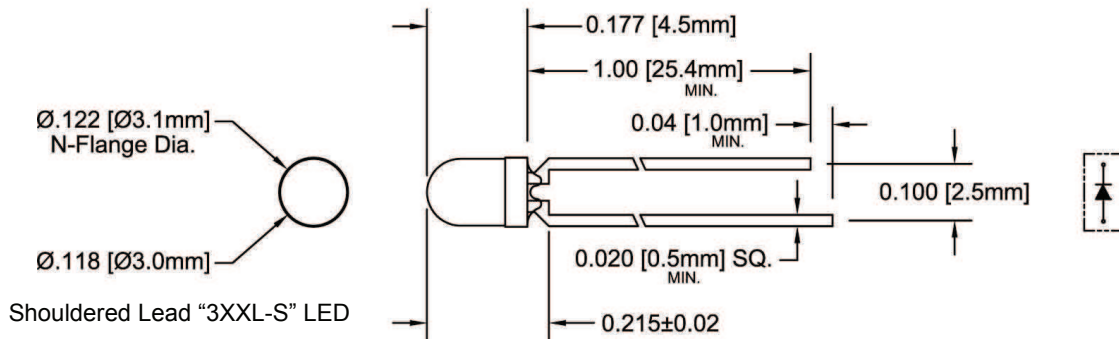
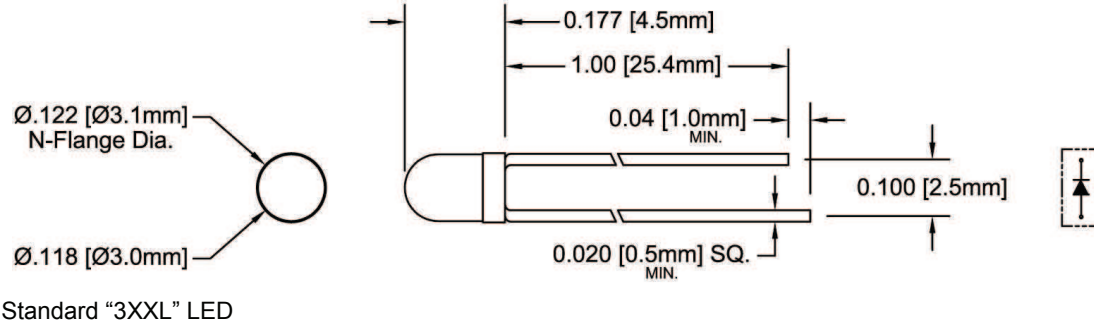
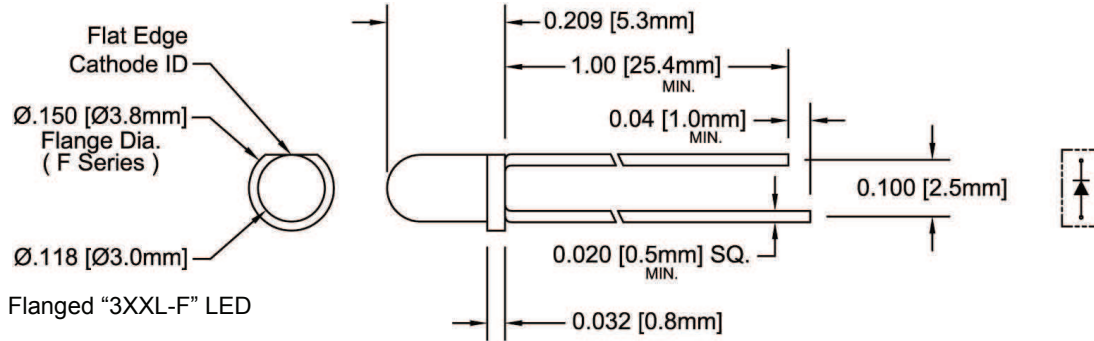

**Recommended Mounting**  
 Hole Size =  $\varnothing.032^{+.003}_{-.002}$

**NOTE:** Add suffix -LL for long lead.  
 Changes 1.00 Min. to 1.57 Min.  
**Standard Lead Only**

- Outline Drawings Notes:**
1. All dimensions are in inches [millimeters].
  2. Standard tolerance:  $\pm 0.010''$  unless otherwise noted.
  3. Tolerance of overall epoxy outline:  $\pm 0.020''$  unless otherwise noted.
  4. Epoxy meniscus may extend to 0.060" max.

Bivar reserves the right to make changes at any time without notice.

# 3mm (T1) Package Discrete LED GREEN, Low Current



## Absolute Maximum Ratings

T<sub>A</sub> = 25°C unless otherwise noted

Power Dissipation	10 mW
Forward Current ( DC )	7 mA
Peak Forward Current <sup>1</sup>	/ mA
Reverse Voltage	V
Operating Temperature Range	-25 ~ +85°C
Storage Temperature Range	-30 ~ +100°C
Lead Soldering Temperature ( 3 mm from the base of the epoxy bulb ) <sup>2</sup>	260°C

Notes: 1. 10% Duty Cycle, Pulse Width ≤ 0.1 msec.      2. Solder time less than 5 seconds at temperature extreme.

## Electrical / Optical Characteristics

T<sub>A</sub> = 25°C & I<sub>F</sub> = 2 mA unless otherwise noted

Part Number	Forward Voltage (V) <sup>1</sup>			Recommend Forward Current (mA)			Reverse Current (μA)	Dominant Wavelength (nm) <sup>2</sup>			Luminous Intensity I <sub>v</sub> (mcd)			Viewing Angle 2Θ ½ (deg)
	MIN	TYP	MAX	MIN	TYP	MAX	MAX	MIN	TYP	MAX	MIN	TYP	MAX	TYP
3PGDL-F								/	/	/	/	0.2	/	35
3PGDL	/	2.1	2.6	/	2	/	100	/	/	/	/	0.2	/	40
3PGDL-S								/	/	/	/	0.2	/	40

Notes: 1. Tolerance of forward voltage : ±0.05V.      2. Tolerance of dominant wavelength : ±1.0nm.

Bivar reserves the right to make changes at any time without notice.

# 3mm (T1) Package Discrete LED GREEN, Low Current



## Typical Electrical / Optical Characteristics

$T_A = 25^\circ\text{C}$  unless otherwise noted

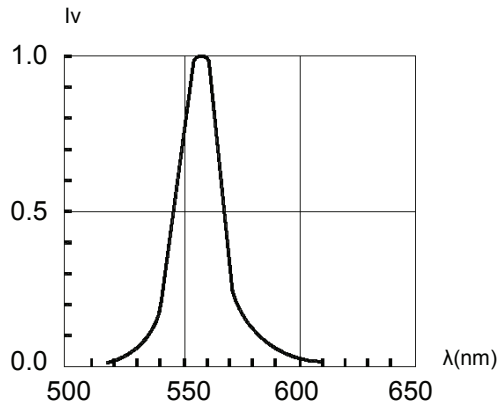

Fig. 1 Relative Luminous Intensity vs. Wavelength

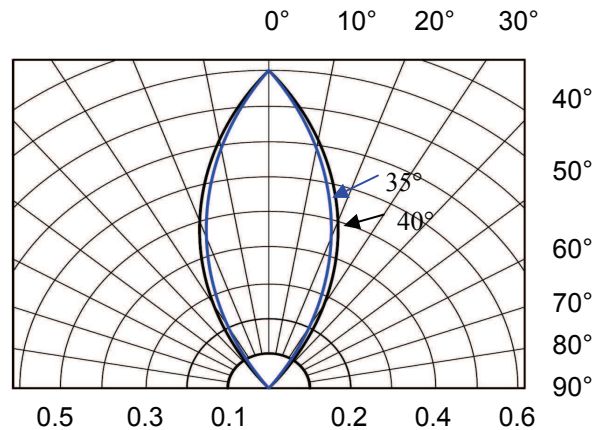

Fig. 2 Directivity Radiation Diagram

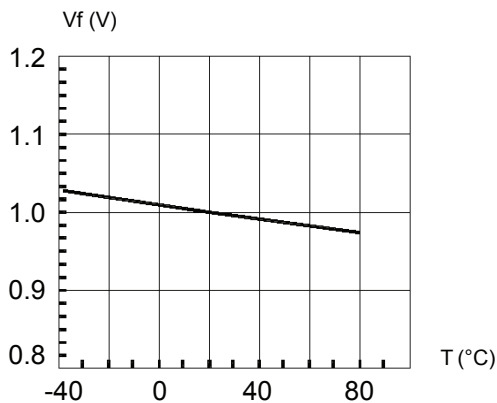

Fig. 3 Forward Voltage vs. Temperature

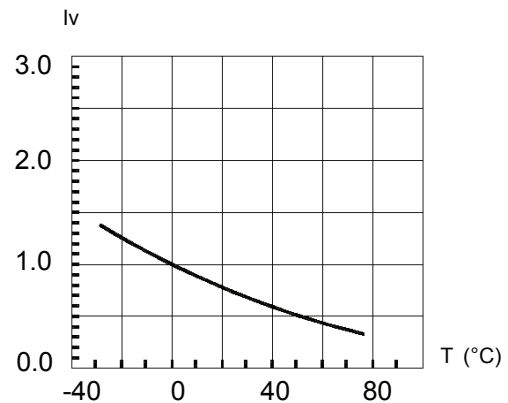

Fig. 4 Relative Luminous Intensity vs. Temperature

Bivar reserves the right to make changes at any time without notice.

# 3mm (T1) Package Discrete LED GREEN, Low Current



## Recommended Soldering Conditions

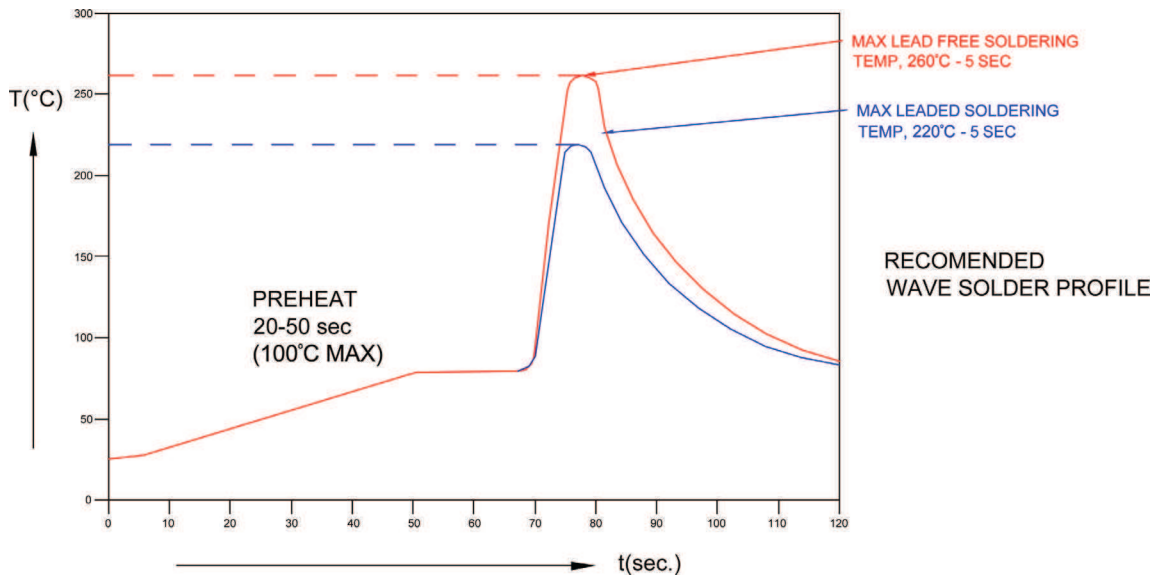

Recommended Lead Free Wave Soldering Profile	
Preheat Temperature: 100°C Max.	Peak Temperature: 260°C Max.
Preheat Time: 20 ~ 50 Seconds	Solder Time Above 217°C: 5 Seconds Max.
Note: Turn off top heater at preheat to prevent the lamp body directly exposed to the heat source.	

## Packaging and Labeling Plan

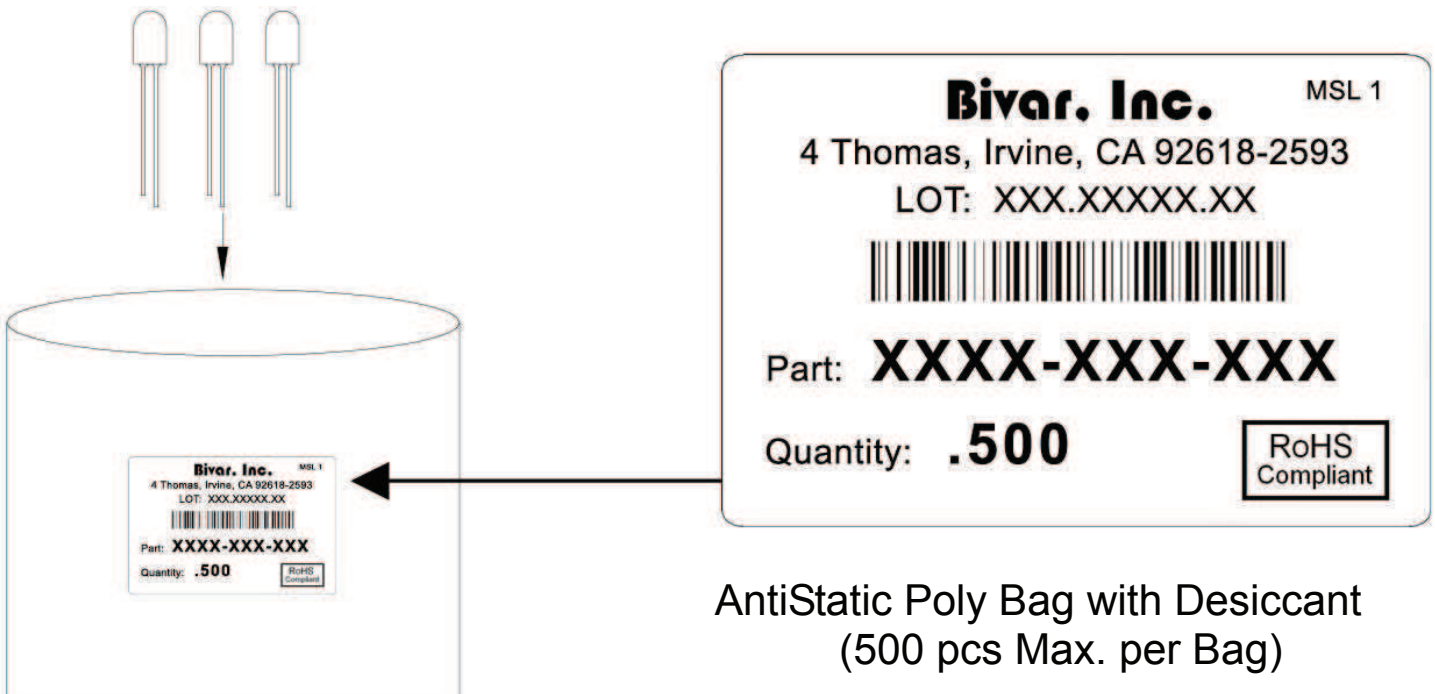

Bivar reserves the right to make changes at any time without notice.