

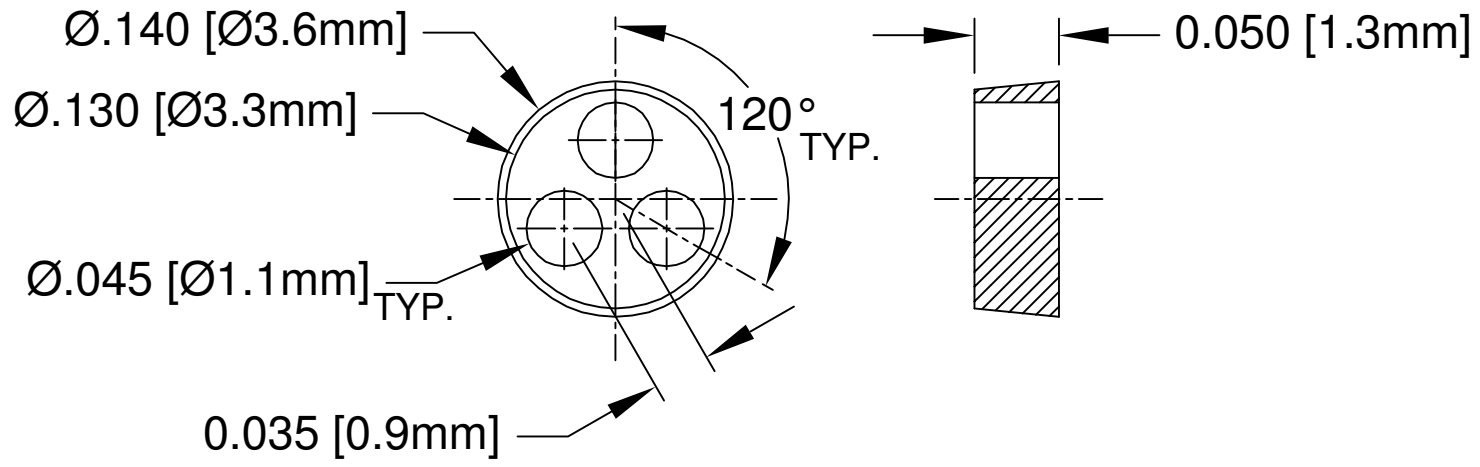
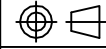

REV.	DESCRIPTION	DATE	APPROVED
A	Engineering Update w/o Changes	02/16/04	M. C.



- 2. MATERIAL: NYLON 6/6, 94V-2, WHITE. BIVAR MATERIAL CODE 04-WE. BASF ULTRAMID NYLON 6/6 A3K WHITE.
- 1. GENERAL SPECIFICATIONS: BIVAR MOLDED COMPONENT SPECIFICATION BV00-E101.

STANDARD TOLERANCE (UNLESS OTHERWISE SPECIFIED)		 BIVAR [®] 4 THOMAS, IRVINE, CA. 92618 TEL: (949) 951-8808 FAX: (949) 951-3974			
DECIMALS	ANGULAR				
.X ± .1	X° ± 1°	 TITLE: PERM-O-PAD TO-18 MOUNT			
.XX ± .01					
.XXX ± .005		DESIGNED: Shane Irving	DATE: 06/19/98	PART NO: 123-050	REVISION: A
		CHECKED: D. Green	DATE: 02/16/04	CAGE CODE : 32559	SHEET # 1 OF 1
CAD GENERATED DOCUMENT, DO NOT MEASURE DRAWING.					