



SOLID STATE DEVICES, INC.
 14830 Valley View Blvd * La Mirada, Ca 90638
 Phone: (562) 404-7855 * Fax: (562) 404-1773

SPT6060/3

DESIGNER'S DATA SHEET

**20 AMP
 350 VOLTS
 NPN DARLINGTON
 TRANSISTOR**

FEATURES:

- High Voltage Rating - 350V Sustaining
- Fast Switching Capabilities / Fast Turn-off Time
- Thermally Stable Structure for Reliability in Power Cycling
- Overload Short Circuit Rating

APPLICATIONS:

- High Voltage Switching Power Supplies
- Inverter / Regulators
- Deflection Circuits
- Pulse-Width-Modulated (PWM) System Control Circuits

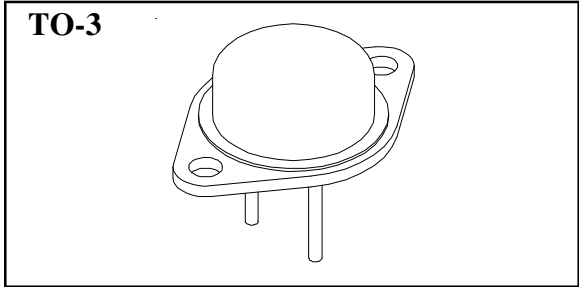

MAXIMUM RATINGS	SYMBOL	VALUE	UNITS
Collector-Emitter Voltage	V _{CEO}	350	Volts
Collector-Base Voltage	V _{CBO}	350	Volts
Collector Current	I _C I _{CM}	20 40	Amps
Base Current	I _B I _{BM}	4 6	Amps
Total Device Dissipation Derate above 25°C	P _D	125 1	W W/°C
Operating and Storage Temperature	T _J , T _{STG}	-65 to +150	°C
Thermal Resistance, Junction to Case	R _{θJC}	1	°C/W

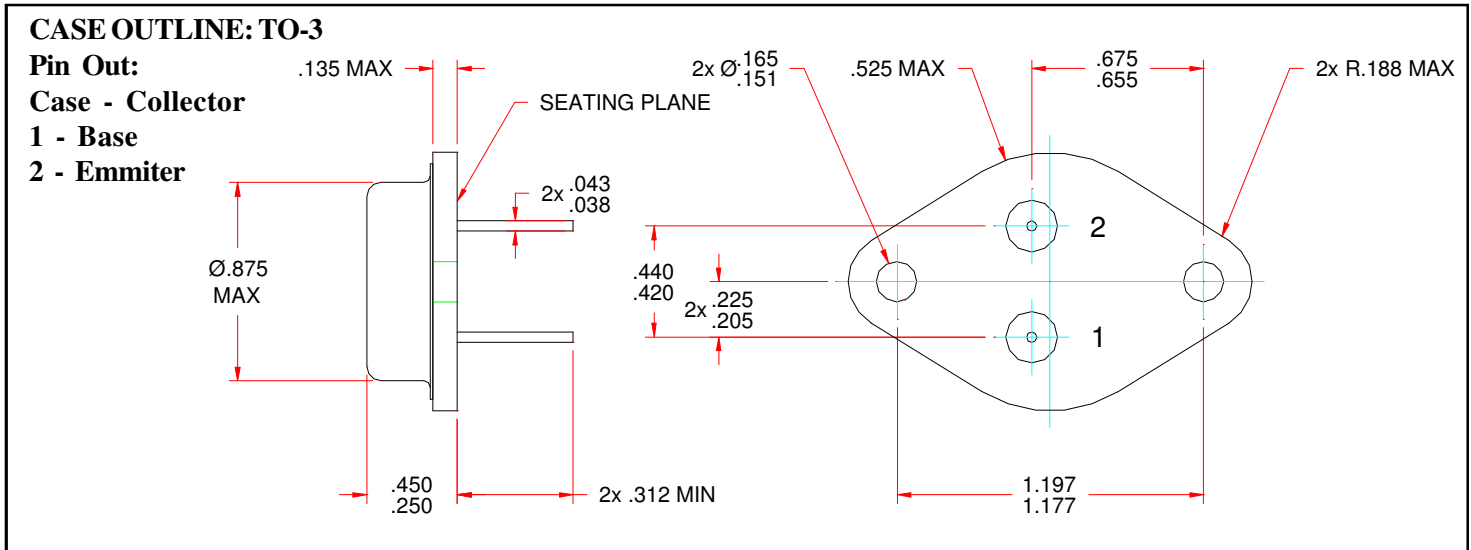

NOTE: All specifications are subject to change without notification. SCD's for these devices should be reviewed by SSDI prior to release.

DATA SHEET #: TR0017B

SPT6060/3



SOLID STATE DEVICES, INC.

14830 Valley View Blvd * La Mirada, Ca 90638
Phone: (562) 404-7855 * Fax: (562) 404-1773

ELECTRICAL CHARACTERISTICS		SYMBOL	MIN	MAX	UNITS
Collector-Emitter Sustaining Voltage ($I_C = 2A$, $L = 2mH$)		$V_{CEO(sus)}$	300	-	V_{DC}
Collector Cutoff Current ($V_{CE} = \text{Rated Value}$, $T_C = 25^\circ C$)		I_{CEO}	-	1.0	mA_{DC}
Emitter Cutoff Current ($V_{EB} = 4V_{DC}$, $I_C = 0$)		I_{EBO}	-	300	mA_{DC}
Overload Short Circuit Rating ($V_{CEO(sus)} = 300V$, $I_C = 30A$, $I_B = 300mA$, $\text{Time} = 10 : s$)			90	-	mJ
Forward Bias Safe Operating Area	$V_{CE} = 6.25V$, $t = 1sec$	FBSOA	20	-	A
	$V_{CE} = 12.5V$, $t = 1sec$		10	-	
	$V_{CE} = 300V$, $t = 1sec$		0.125	-	
DC Current Gain* ($V_{CE} = 5V_{DC}$)	$I_C = 10A_{DC}$	H_{FE}	30	120	
	$I_C = 15A_{DC}$		20	80	
	$I_C = 20A_{DC}$		15	60	
Collector-Emitter Saturation Voltage*	$I_C = 10A_{DC}$, $I_B = 2A_{DC}$	$V_{CE(SAT)}$		1.4	V_{DC}
	$I_C = 10A_{DC}$, $I_B = 1A_{DC}$			1.5	
	$I_C = 20A_{DC}$, $I_B = 2A_{DC}$			2.0	
Base-Emitter Saturation Voltage*	$I_C = 10A_{DC}$, $I_B = 2A_{DC}$	$V_{BE(SAT)}$	-	2.5	V_{DC}
	$I_C = 20A_{DC}$, $I_B = 2A_{DC}$		-	3.0	
Small Signal Current Gain ($I_C = 1A_{DC}$, $V_{CE} = 10V_{DC}$, $f = 1MHz$)		h_{FE}	10		
Rise Time	$V_{CC} = 150V_{DC}$, $I_C = 10A_{DC}$, $I_{B1} = I_{B2} = 1.0A_{DC}$, $t_p = 4\mu s \text{ min.}$	t_r	-	0.4	μs
Storage Time		t_s	-	2.5	μs
Fall Time		t_f	-	1.0	μs

*Pulse Test: Pulse Width = 300 μs , Duty Cycle = 2%

NOTE: All specifications are subject to change without notification.
SCD's for these devices should be reviewed by SSDI prior to release.

DATA SHEET #: TR0017B