



Solid State Devices, Inc.

14701 Firestone Blvd * La Mirada, Ca 90638
 Phone: (562) 404-7855 * Fax: (562) 404-1773
 ssdi@ssdi-power.com * www.ssdi-power.com

SFF130/3 & SFF130/66

**14 AMP / 100 Volts
 0.18 Ω
 N-Channel Power MOSFET**

DESIGNER'S DATA SHEET

Part Number / Ordering Information^{1/}

SFF130

└ Screening^{2/}
 — = Not Screen
 TX = TX Level
 TXV = TXV Level
 S = S Level

Package
 /3= TO-3
 /66= TO-66

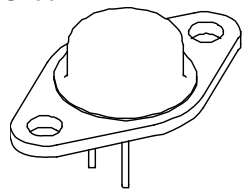
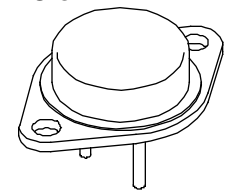
TO-66  **TO-3** 

- Features:**
- Rugged Construction with Poly Silicon Gate
 - Low R_{DS(ON)} and High Transconductance
 - Excellent High Temperature Stability
 - Very Fast Switching Speed
 - Fast Recovery and Superior dV/dt Performance
 - Increased Reverse Energy Capability
 - Low Input and Transfer Capacitance for Easy Paralleling
 - Hermetically Sealed Package
 - Available in both hot case and isolated versions
 - Ideal for low power applications
 - TX, TXV, Space Level Screening Available^{2/}
 - Replacement for IRFF130 & 2N6756 Types

Maximum Ratings		Symbol	Value	Units
Drain – Source Voltage		V _{DS}	100	Volts
Gate – Source Voltage		V _{GS}	±20	Volts
Continuous Collector Current	T _C = 25°C T _C = 100°C	I _D	14 9	Amps
Power Dissipation	T _C = 25°C T _A = 25°C	P _D	25 19	Watts
Operating & Storage Temperature		Top & Tstg	-55 to +150	°C
Thermal Resistance Junction to Case		R _{θJC}	5	°C/W
Single Pulse Avalanche Energy		E _{AS}	75	mJ
Repetitive Avalanche Energy		E _{AR}	7.5	mJ

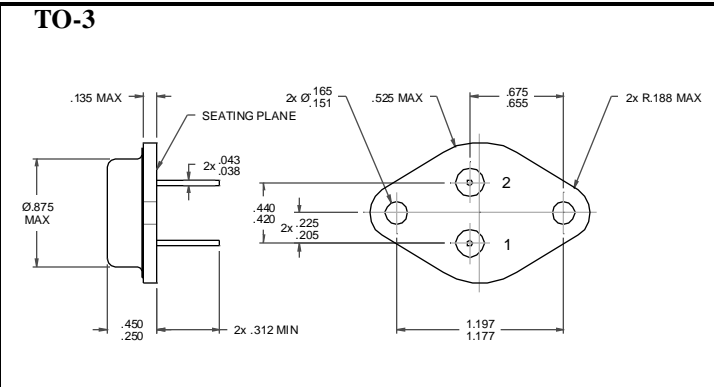
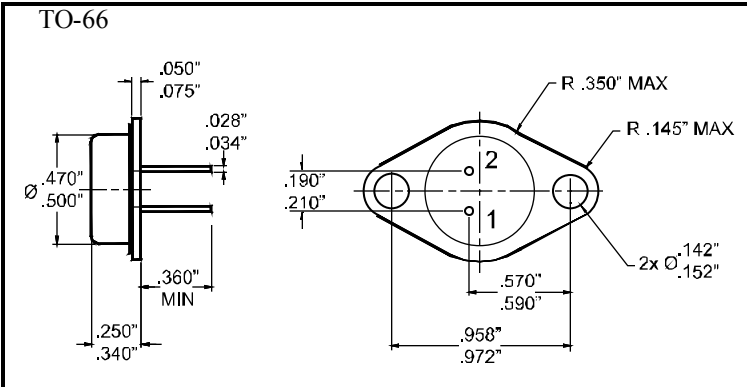

NOTES: 1/ For Ordering Information, Price, Operating Curves, and Availability- Contact Factory.
 2/ Screened to MIL-PRF-19500/542.
 3/ Unless Otherwise Specified, All Maximum Ratings and Electrical Characteristics @25°C.



Solid State Devices, Inc.

14701 Firestone Blvd * La Mirada, Ca 90638
 Phone: (562) 404-7855 * Fax: (562) 404-1773
 ssdi@ssdi-power.com * www.ssdi-power.com

SFF130/3 & SFF130/66

Electrical Characteristics @ T _J = 25°C (Unless Otherwise Specified)		Symbol	Min	Typ	Max	Units
Drain to Source Breakdown Voltage (VGS=0 V, ID=250 μA)		BV _{DSS}	100	—	—	Volts
Temperature Coefficient of Breakdown Voltage		$\frac{\Delta BV_{DSS}}{\Delta T_j}$	—	130	—	mV/°C
Drain to Source On State Resistance (VGS=10 V)	ID=9A ID=14A	R _{DS(on)}	—	0.13 0.14	0.18 0.21	Ω
Gate Threshold Voltage (VDS=VGS, ID=250 μA)		V _{GS(th)}	2.0	2.8	4.0	V
Forward Transconductance (VDS>ID(on) X RDS(on) Max, IDS= 9A)		g _{fs}	4.6	7	—	mho
Zero Gate Voltage Drain Current (VDS=80% max rated voltage, VGS=0 V) (VDS=80% rated VDS, VGS=0 V, TA=125°C)		I _{DSS}	— —	— —	25 250	μA
Gate to Source Leakage Forward Gate to Source Leakage Reverse	At rated VGS	I _{GSS}	— —	— —	+100 -100	nA
Total Gate Charge Gate to Source Charge Gate to Drain Charge	VGS=10 Volts 50% rated VDS Rated ID	Q _g Q _{gs} Q _{gd}	12 1.5 5	17 3.7 7.0	35 10 20	nC
Turn on Delay Time Rise Time Turn on Delay Time Fall Time	VDD=50% Rated VDS 50% rated ID RG= 7.5Ω	t _{d(on)} t _r t _{d(off)} t _f	— — — —	9.5 42 22 25	35 80 60 45	nsec
Diode Forward Voltage (IS= Rated ID, VGS=0 V, T _J =25°C)		V _{SD}	—	1	1.5	V
Diode Reverse Recovery Time Reverse Recovery Charge	T _J =25°C IF=10A Di/dt=100A/μsec	t _{rr} Q _{RR}	— —	120 0.58	300 3	nsec μC
Input Capacitance Output Capacitance Reverse Transfer Capacitance	VGS=0 Volts VDS=25 Volts f=1 MHz	C _{iss} C _{oss} C _{rss}	— — —	650 250 44	— — —	pF

For thermal derating curves and other characteristics please contact SSDI Marketing Department.

Available Part Number:
SFF130/3; SFF130/66

PIN ASSIGNMENT (Standard)

Package	Drain	Source	Gate
TO-3	Case	Pin 2	Pin 1
TO-66	Case	Pin 2	Pin 1

NOTE: All specifications are subject to change without notification.
 SCD's for these devices should be reviewed by SSDI prior to release.

DATA SHEET #: F00307B

DOC