



Solid State Devices, Inc.

14830 Valley View Blvd * La Mirada, Ca 90638

Phone: (562) 404-7855 * Fax: (562) 404-1773

ssdi@ssdi-power.com * www.ssdi-power.com

**SFF24N50/3
SFF24N50/3T**

**24 AMP / 500 Volts
0.2 Ω
N-Channel
Power MOSFET**

DESIGNER'S DATA SHEET

Features:

- Rugged Construction with Polysilicon Gate Cell
- Low $R_{DS(ON)}$ and High Transconductance
- Excellent High Temperature Stability
- Very Fast Switching Speed
- Fast Recovery and Superior dV/dt Performance
- Increased Reverse Energy Capability
- Low Input and Transfer Capacitance for Easy Paralleling
- Hermetically Sealed Surface Mount Power Package
- TX, TXV, Space Level Screening Available
- Replacement for IXTH24N50 Types

TO-3

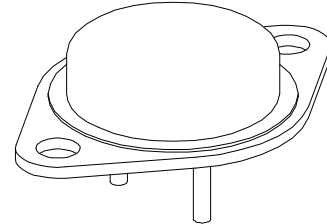

Maximum Ratings		Symbol	Value	Units
Drain – Source Voltage		V_{DS}	500	Volts
Gate – Source Voltage		V_{GS}	±20	Volts
Continuous Drain Current (Tj limited)		I_D	24	Amps
Avalanche Current	Repetitive	I_{AR}	21	Amps
Avalanche Energy	Repetitive Single Pulse	E_{AR} E_{AS}	1 690	mJ
Operating & Storage Temperature		Top & Tstg	-55 to +150	°C
Thermal Resistance, Junction to Case		$R_{\theta JC}$	0.75 (typ 0.6)	°C/W
Total Device Dissipation @ TC=25°C		PD	167	WATTS
Total Device Dissipation @ TC=55°C			126	

Package Outline: TO-3

Pin Out:

Pin 1: GATE

Pin 2: SOURCE

Pin 3: DRAIN

Notes:

1. P/N: SFF 24N50/3:

Pin Diameter : 0.043"

0.038"

2. P/N: SFF24N50/3T:

Pin Diameter: 0.063"

0.058"

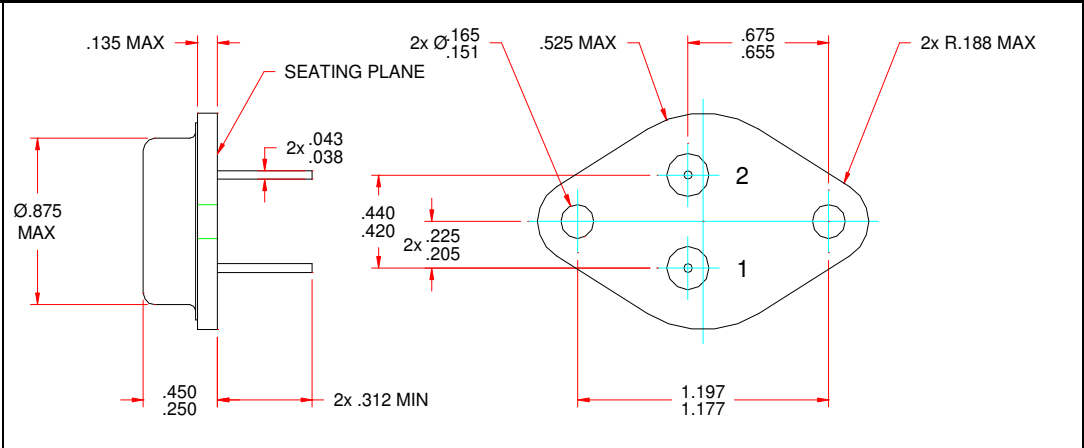

NOTE: All specifications are subject to change without notification. SCD's for these devices should be reviewed by SSDI prior to release.

DATA SHEET #: F00175E

DOC



Solid State Devices, Inc.

14830 Valley View Blvd * La Mirada, Ca 90638

Phone: (562) 404-7855 * Fax: (562) 404-1773

ssdi@ssdi-power.com * www.ssdi-power.com

SFF24N50/3 SFF24N50/3T

Electrical Characteristics @ T _J = 25°C (Unless Otherwise Specified)		Symbol	Min	Typ	Max	Units
Drain to Source Breakdown Voltage (VGS=0 V, ID=250 μA)		BV _{DSS}	500	—	—	Volts
Drain to Source On State Resistance (VGS=10 V, ID=50% Rated ID)		R _{DS(on)}	—	—	0.2	Ω
On State Drain Current (VDS>ID(on) X RDS(on) Max, VGS=10V)		I _{D(on)}	24	—	—	A
Gate Threshold Voltage (VDS=VGS, ID= 4mA)		V _{GS(th)}	2.0	—	4.0	V
Forward Transconductance (VDS>ID(on) X RDS(on) Max, IDS= 50% Rated ID)		g _{fs}	8	12	—	mho
Zero Gate Voltage Drain Current (VDS=max rated voltage, VGS=0 V) (VDS=80% rated VDS, VGS=0 V, TA=125°C)		I _{DSS}	—	—	250 1000	μA
Gate to Source Leakage Forward Gate to Source Leakage Reverse	At rated VGS	I _{GSS}	—	—	+100 -100	nA
Total Gate Charge	VGS=10 Volts	Q _g	—	135	180	nC
Gate to Source Charge	50% rated VDS	Q _{gs}	—	28	40	
Gate to Drain Charge	50% Rated ID	Q _{gd}	—	62	85	
Turn on Delay Time	VDD=50% Rated VDS	t _{d(on)}	—	16	30	nsec
Rise Time	50% Rated ID	t _r	—	33	45	
Turn on Delay Time	RG= 6.2Ω	t _{d(off)}	—	65	130	
Fall Time	VGS=10 Volts	t _f	—	30	40	
Diode Forward Voltage (IS= Rated ID, VGS=0 V, T _J =25°C)		V _{SD}	—	—	1.5	V
Diode Reverse Recovery Time	T _J =25°C	t _{rr}	—	—	500	nsec
Reverse Recovery Charge	IF=10A Di/dt=100A/μsec	Q _{RR}	—	—	—	nC
Input Capacitance	VGS=0 Volts	C _{iss}	—	4200	—	pF
Input Capacitance	VDS=25 Volts	C _{oss}	—	450	—	
Reverse Transfer Capacitance	f=1 MHz	C _{rss}	—	135	—	

For thermal derating curves and other characteristics please contact SSDI Marketing Department.

NOTE: All specifications are subject to change without notification.
SCD's for these devices should be reviewed by SSDI prior to release.

DATA SHEET #: F00175E

DOC