



Solid State Devices, Inc.

14701 Firestone Blvd * La Mirada, Ca 90638
 Phone: (562) 404-4474 * Fax: (562) 404-1773
 ssdi@ssdi-power.com * www.ssdi-power.com

**SFF250M
 SFF250Z**

**30 AMP / 200 Volts
 0.060 Ω typical
 N-Channel POWER MOSFET**

DESIGNER'S DATA SHEET

Part Number / Ordering Information ^{1/}

SFF250

- Screening ^{2/} ___ = Not Screen
 TX = TX Level
 TXV = TXV Level
 S = S Level
- Lead Option ^{3/} ___ = Straight Leads
 DB = Down Bend
 UB = Up Bend
- Package ^{3/} M = TO-254
 Z = TO-254Z

- Features:**
- Rugged Construction with Polysilicon Gate Cell
 - Low R_{DS(ON)} and High Transconductance
 - Excellent High Temperature Stability
 - Very Fast Switching Speed
 - Fast Recovery and Superior dV/dt Performance
 - Increased Reverse Energy Capability
 - Low Input and Transfer Capacitance for Easy Paralleling
 - Ceramic Seals Available for Improved Hermeticity
 - Hermetically Sealed Surface Mount Power Package
 - TX, TXV, Space Level Screening Available
 - Replacement for IRFM250 Types

Maximum Ratings		Symbol	Value	Units
Drain – Source Voltage		V _{DS}	200	Volts
Gate – Source Voltage		V _{GS}	±20	Volts
Continuous Collector Current		I _D	30	Amps
Operating & Storage Temperature		Top & Tstg	-55 to +150	°C
Maximum Thermal Resistance Junction to Case		R _{θJC}	1	°C/W
Total Device Dissipation	T _C = 25°C T _C = 55°C	P _D	125 95	W

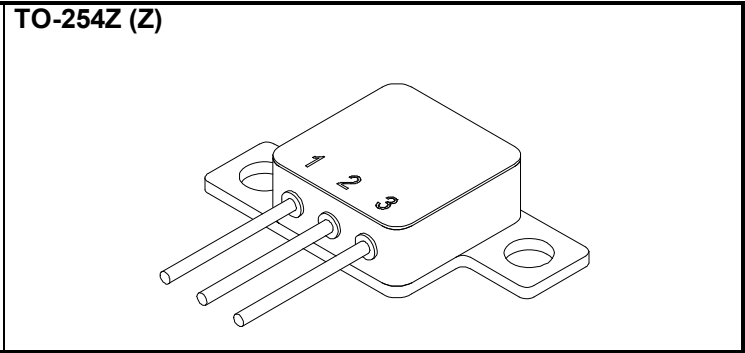
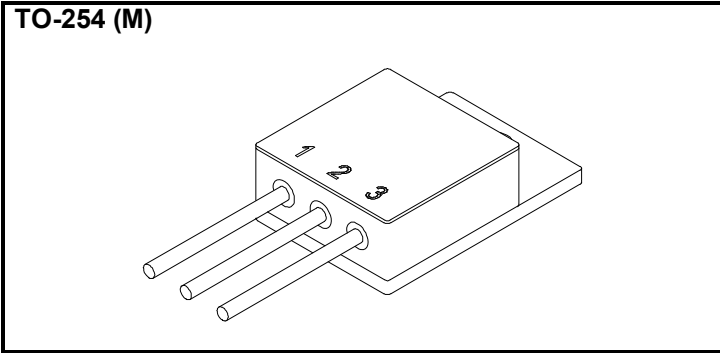

For Pin Out Configuration and Optional Lead Bend, See Page 3.



Solid State Devices, Inc.

14701 Firestone Blvd * La Mirada, Ca 90638
Phone: (562) 404-4474 * Fax: (562) 404-1773
ssdi@ssdi-power.com * www.ssdi-power.com

SFF250M SFF250Z

Electrical Characteristics @ T _J = 25°C (Unless Otherwise Specified)		Symbol	Min	Typ	Max	Units
Drain to Source Breakdown Voltage (VGS= 0 V, ID= 250μA)		BV _{DSS}	200	—	—	V
Drain to Source On State Resistance (VGS= 10 V, ID= 18 A)		R _{DS(on)}	—	0.06	0.085	Ω
Gate Threshold Voltage (VDS= VGS, ID= 250μA)		V _{GS(th)}	2	3	5	V
Forward Transconductance (VDS ≥ I _{N(on)} X R _{DS(on)} Max, ID= 18 A)		g _{fs}	10	17	—	mho
Zero Gate Voltage Drain Current (VDS= 200 V, VGS= 0 V) (VDS= 200 V, VGS= 0 V, TA= 125°C)		I _{DSS}	—	—	25 250	μA
Gate to Source Leakage Forward Gate to Source Leakage Reverse	At rated VGS	I _{GSS}	—	—	+100 -100	nA
Total Gate Charge Gate to Source Charge Gate to Drain Charge	VGS=10 V VDS= 100 V ID= 30 A	Q _g Q _{gs} Q _{gd}	—	70 18 35	120 25 65	nC
Turn on Delay Time Rise Time Turn on Delay Time Fall Time	VDD= 100 V ID= 15 A RG= 6.2Ω	td _(on) tr td _(off) tf	—	29 35 75 35	30 180 100 120	nsec
Diode Forward Voltage (IS= 30 A, VGS= 0 V, T _J = 25°C)		V _{SD}	—	1.1	1.5	V
Diode Reverse Recovery Time Reverse Recovery Charge	T _J = 25°C IF= 10 A di/dt= 100 A/μsec	t _{rr} Q _{RR}	—	150 2.0	630 8	nsec μC
Input Capacitance Input Capacitance Reverse Transfer Capacitance	VGS= 0 Volts VDS= 25 Volts f= 1 MHz	C _{iss} C _{oss} C _{rss}	—	4200 650 120	— — —	pF

For thermal derating curves and other characteristics please contact SSDI Marketing Department.

Available Part Numbers:

SFF250M; SFF250MDB; SFF250MUB;
SFF250Z; SFF250ZDB; SFF250ZUB;

PIN ASSIGNMENT (Standard)

Package	Drain	Source	Gate
TO-254 (M)	Pin 1	Pin 2	Pin 3
TO-254Z (Z)	Pin 1	Pin 2	Pin 3

NOTE: All specifications are subject to change without notification.
SCD's for these devices should be reviewed by SSDI prior to release.

DATA SHEET #: F00049E

DOC



Solid State Devices, Inc.

14701 Firestone Blvd * La Mirada, Ca 90638
Phone: (562) 404-4474 * Fax: (562) 404-1773
ssdi@ssdi-power.com * www.ssdi-power.com

**SFF250M
SFF250Z**

Case Outline: TO-254 (M)

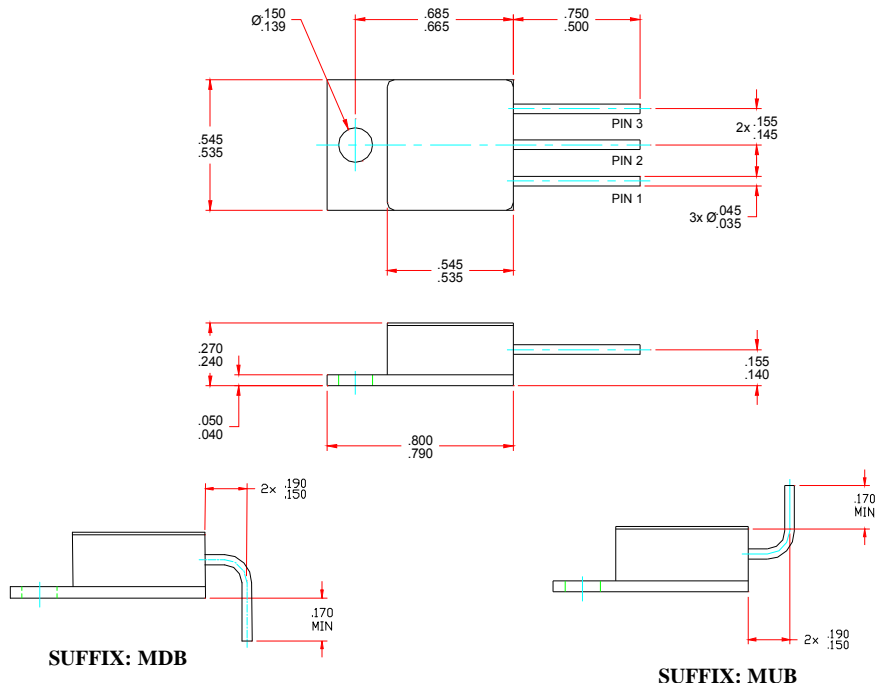

Case Outline: TO-254Z (Z)

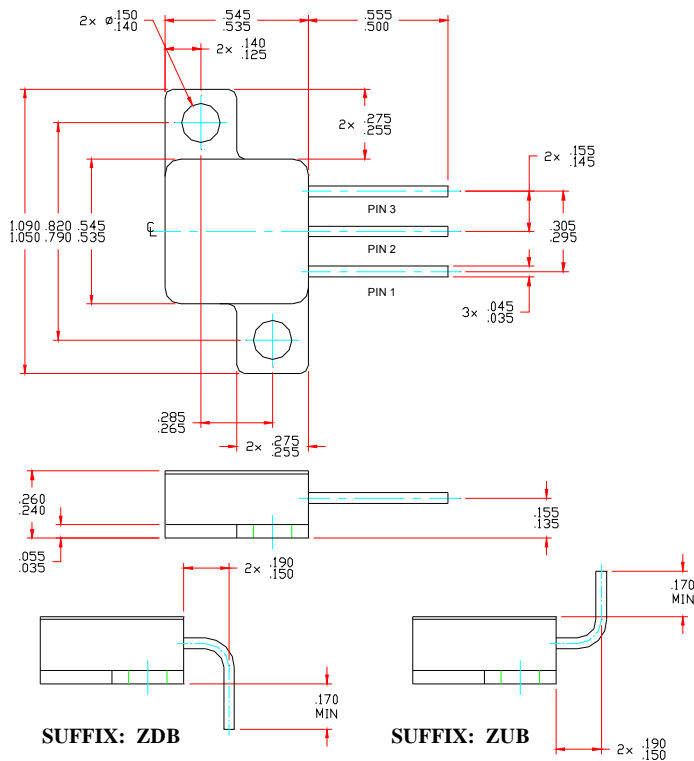

NOTE: All specifications are subject to change without notification.
SCD's for these devices should be reviewed by SSDI prior to release.

DATA SHEET #: F00049E

DOC