



**Solid State Devices, Inc.**

14830 Valley View Blvd \* La Mirada, Ca 90638

Phone: (562) 404-7855 \* Fax: (562) 404-1773

ssdi@ssdi-power.com \* www.ssdi-power.com

**DESIGNER'S DATA SHEET**

TO-254 and TO-254Z

**Note 1: maximum current limited by package configuration**

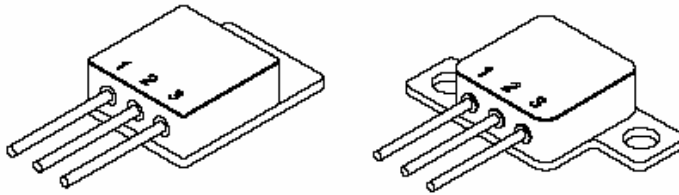

**SFF75N08M**  
**SFF75N08Z**

**55 AMP (note 1) /75 Volts**  
**8.5 mO**

**N-Channel Trench Gate MOSFET**

**Features:**

- Trench gate technology for high cell density
- Lowest ON-resistance in the industry
- Enhanced operating temperature range
- Hermetically Sealed, Isolated Package
- Low Total Gate Charge
- Fast Switching
- Enhanced replacement for IRF7MS2907
- TX, TXV, S-Level screening available
- Improved ( $R_{DS(ON)}$   $Q_G$ ) figure of merit

Maximum Ratings		Symbol	Value	Units
Drain - Source Voltage		$V_{DSS}$	75	V
Gate - Source Voltage		$V_{GS}$	$\pm 20$	V
Max. Continuous Drain Current (package limited)	@ $T_C = 25^\circ C$	$I_{D1}$	55 (note 1)	A
	@ $T_C = 125^\circ C$	$I_{D2}$	55 (note 1)	A
Max. Instantaneous Drain Current ( $T_j$ limited)	@ $T_C = 25^\circ C$	$I_{D3}$	175	A
	@ $T_C = 125^\circ C$	$I_{D4}$	75	A
Max. Avalanche current	@ $L = 0.1$ mH	$I_{AR}$	75	A
Repetitive Avalanche Energy	@ $L = 0.1$ mH	$E_{AR}$	280	mJ
Total Power Dissipation	@ $T_C = 25^\circ C$	$P_D$	210	W
Operating & Storage Temperature		$T_{OP}$ & $T_{STG}$	-55 to +175	$^\circ C$
Maximum Thermal Resistance (Junction to Case)		$R_{\theta JC}$	0.7 (typ 0.55)	$^\circ C/W$

TO-254 (M)

TO-254Z (Z)

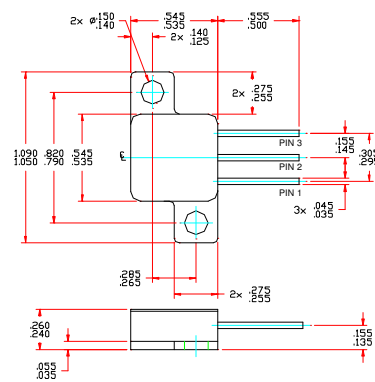
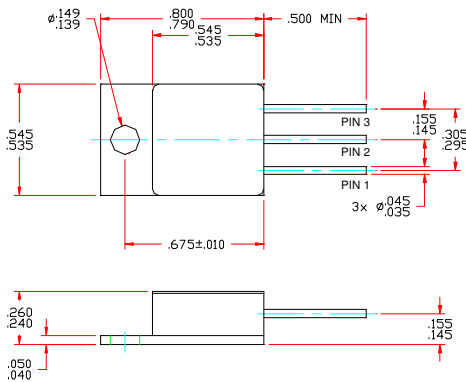

**NOTE:** All specifications are subject to change without notification. SCD's for these devices should be reviewed by SSDI prior to release.

**DATA SHEET #: FT0021A**

**DOC**



**Solid State Devices, Inc.**

14830 Valley View Blvd \* La Mirada, Ca 90638

Phone: (562) 404-7855 \* Fax: (562) 404-1773

ssdi@ssdi-power.com \* www.ssdi-power.com

# SFF75N08M

# SFF75N08Z

Electrical Characteristics <sup>4/</sup>		Symbol	Min	Typ	Max	Units
<b>Drain to Source Breakdown Voltage</b>	$V_{GS} = 0V, I_D = 250\mu A$	$BV_{DSS}$	75	—	—	V
<b>Drain to Source On State Resistance</b>	$V_{GS} = 10V, I_D = 30A, T_j = 25^\circ C$ $V_{GS} = 10V, I_D = 30A, T_j = 125^\circ C$ $V_{GS} = 10V, I_D = 30A, T_j = 175^\circ C$	$R_{DS(on)}$	—	7.5 10.0 12.5	8.5 — —	mO
<b>Gate Threshold Voltage</b>	$V_{DS} = V_{GS}, I_D = 250\mu A$	$V_{GS(th)}$	2.0	—	4.0	V
<b>Gate to Source Leakage</b>	$V_{GS} = \pm 20V$	$I_{GSS}$	—	—	$\pm 100$	nA
<b>Zero Gate Voltage Drain Current</b>	$V_{DS} = 60V, V_{GS} = 0V, T_j = 25^\circ C$ $V_{DS} = 60V, V_{GS} = 0V, T_j = 125^\circ C$ $V_{DS} = 60V, V_{GS} = 0V, T_j = 200^\circ C$	$I_{DSS}$	—	—	1 50 10	$\mu A$ $\mu A$ mA
<b>Forward Transconductance</b>	$V_{DS} = 15V, I_D = 30A, T_j = 25^\circ C$	$g_{fs}$	25	—	—	Mho
<b>Total Gate Charge</b>	$V_{GS} = 10V$	$Q_g$	—	150	220	nC
<b>Gate to Source Charge</b>	$V_{DS} = 35V$	$Q_{gs}$	—	35	—	
<b>Gate to Drain Charge</b>	$I_D = 110A$	$Q_{gd}$	—	50	—	
<b>Turn on Delay Time</b>	$V_{GS} = 10V$	$t_{d(on)}$	—	25	50	nsec
<b>Rise Time</b>	$V_{DS} = 35V$	$t_r$	—	210	300	
<b>Turn off Delay Time</b>	$I_D = 110A$	$t_{d(off)}$	—	70	125	
<b>Fall Time</b>	$R_G = 2.5O$	$t_f$	—	170	275	
<b>Diode Forward Voltage</b>	$I_F = 110A, V_{GS} = 0V$	$V_{SD}$	—	1.1	1.5	V
<b>Diode Reverse Recovery Time</b>	$I_F = 100A, di/dt = 100A/usec$	$t_{rr}$	—	85	135	nsec
<b>Peak Reverse Recovery Current</b>		$I_{RM(Rec)}$	—	4.5	7.5	A
<b>Reverse Recovery Charge</b>		$Q_{rr}$	—	0.16	0.35	$\mu C$
<b>Input Capacitance</b>	$V_{GS} = 0V$	$C_{iss}$	—	8000	—	pF
<b>Output Capacitance</b>	$V_{DS} = 25V$	$C_{oss}$	—	1000	—	
<b>Reverse Transfer Capacitance</b>	$f = 1 MHz$	$C_{rss}$	—	600	—	

**NOTES:**

\* Pulse Test: Pulse Width = 300 $\mu$ sec, Duty Cycle = 2%.

1/ For Ordering Information, Price, and Availability Contact Factory.

2/ Screening per MIL-PRF-19500.

3/ For Package Outlines Contact Factory.

4/ Unless Otherwise Specified, All Electrical Characteristics @25°C.

**Available Part Numbers:**

Consult Factory

**PIN ASSIGNMENT (Standard)**

Package	Drain	Source	Gate
<b>TO-254 (M)</b>	Pin 1	Pin 2	Pin 3
<b>TO-254Z (Z)</b>	Pin 1	Pin 2	Pin 3

**NOTE:** All specifications are subject to change without notification. SCD's for these devices should be reviewed by SSDI prior to release.

**DATA SHEET #: FT0021A**

**DOC**