



Solid State Devices, Inc.

14701 Firestone Blvd * La Mirada, Ca 90638
Phone: (562) 404-4474 * Fax: (562) 404-1773
ssdi@ssdi-power.com * www.ssdi-power.com

SDR620CTM&Z thru SDR622CTM&Z

40 AMP, 100 - 200 VOLTS 35 nsec HYPER FAST CENTERTAP RECTIFIER

Designer's Data Sheet	
Part Number/Ordering Information ^{1/}	
SDR62 _____	
Screening ^{2/}	_____ = Not Screened TX = TX Level TXV = TXV Level S = S Level
Lead Options	_____ = Straight Leads DB = Down Bent UB = Up Bent
Package	M = TO-254 Z = TO-254Z
Configuration	CT = Common Cathode CA = Common Anode D = Doubler DR = Doubler Reverse
Family/Voltage	0 = 100V 1 = 150V 2 = 200V

- FEATURES:**
- Replaces 1N6657, 1N6658, 1N6659 Devices
 - Hyper Fast Recovery: 35 ns Maximum
 - High Surge Rating
 - Low Reverse Leakage Current
 - Low Junction Capacitance
 - Hermetically Sealed Package
 - Gold Eutectic Die Attach Available
 - Ultrasonic Aluminum Wire Bonds
 - TX, TXV, or Space Level Screening Available

Maximum Ratings		Symbol	Value	Units
Peak Repetitive Reverse and DC Blocking Voltage ^{3/}	SDR620 SDR621 SDR622	V_{RRM} V_{RWM} V_R	100 150 200	Volts
Average Rectified Forward Current ^{4/} (Resistive Load, 60 Hz Sine Wave, $T_C = 100^\circ\text{C}$)		I_O	40	Amps
Peak Surge Current (8.3 ms Pulse, Half Sine Wave, $T_A = 25^\circ\text{C}$, per leg)		I_{FSM}	200	Amps
Operating & Storage Temperature		T_{OP} & T_{STG}	-65 to +200	$^\circ\text{C}$
Maximum Total Thermal Resistance Junction to Case, each individual diode Junction to Case ^{4/}		$R_{\theta JC}$	2.0 1.2	$^\circ\text{C/W}$

NOTES:

- ^{1/} For ordering Information, Price, and Availability, Contact Factory.
- ^{2/} Screening per MIL-PRF-19500.
- ^{3/} Higher voltages available.
- ^{4/} Both Legs Tied Together.

TO-254

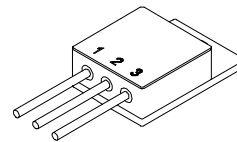

TO-254Z

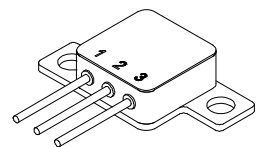

NOTE: All specifications are subject to change without notification. SCD's for these devices should be reviewed by SSDI prior to release.

DATA SHEET #: RC0027F

DOC



Solid State Devices, Inc.

14701 Firestone Blvd * La Mirada, Ca 90638
 Phone: (562) 404-4474 * Fax: (562) 404-1773
 ssdi@ssdi-power.com * www.ssdi-power.com

**SDR620CTM&Z
 thru
 SDR622CTM&Z**

Electrical Characteristic (Per Leg)		Symbol	Typ	Max	Units
Instantaneous Forward Voltage Drop ($T_A = 25^\circ\text{C}$, 300 – 500 μsec Pulse)	$I_F = 10\text{ A}$	V_{F1}	0.86	1.0	V_{DC}
	$I_F = 20\text{ A}$	V_{F2}	0.96	1.2	
Instantaneous Forward Voltage Drop ($I_F = 10\text{ A}$, 300 – 500 μsec Pulse)	$T_A = 100^\circ\text{C}$	V_{F3}	0.76	0.9	V_{DC}
	$T_A = -55^\circ\text{C}$	V_{F4}	0.98	1.15	
Reverse Leakage Current (100% of rated V_R , 300 μs pulse min.)	$T_A = 25^\circ\text{C}$	I_{R1}	0.02	10	μA
	$T_A = 100^\circ\text{C}$	I_{R2}	2	1000	
Reverse Recovery Time ($I_F = 0.5\text{ A}$, $I_R = 1\text{ A}$, $I_{RR} = 0.25\text{ A}$, $T_A = 25^\circ\text{C}$)		t_{RR}	22	35	nsec
Junction Capacitance ($V_R = 10\text{ V}_{DC}$, $T_A = 25^\circ\text{C}$, $f = 1\text{ MHz}$)		C_J	180	225	pF

TO-254

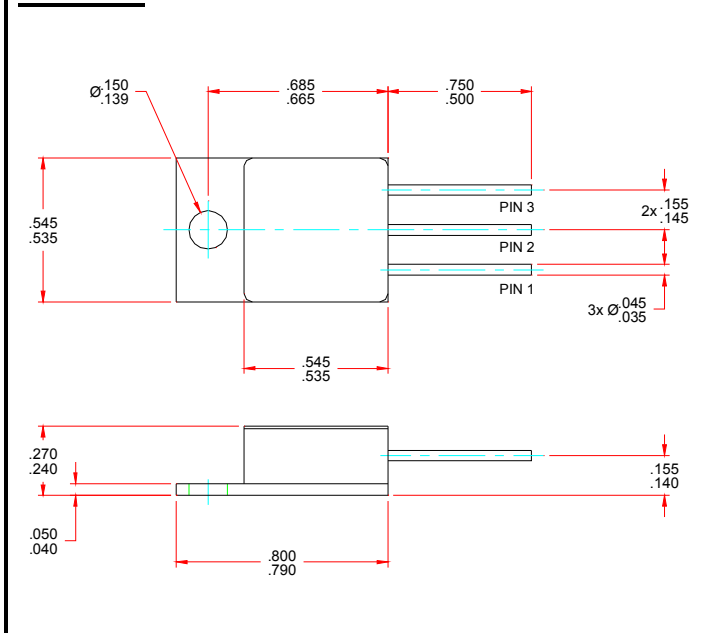

TO-254Z

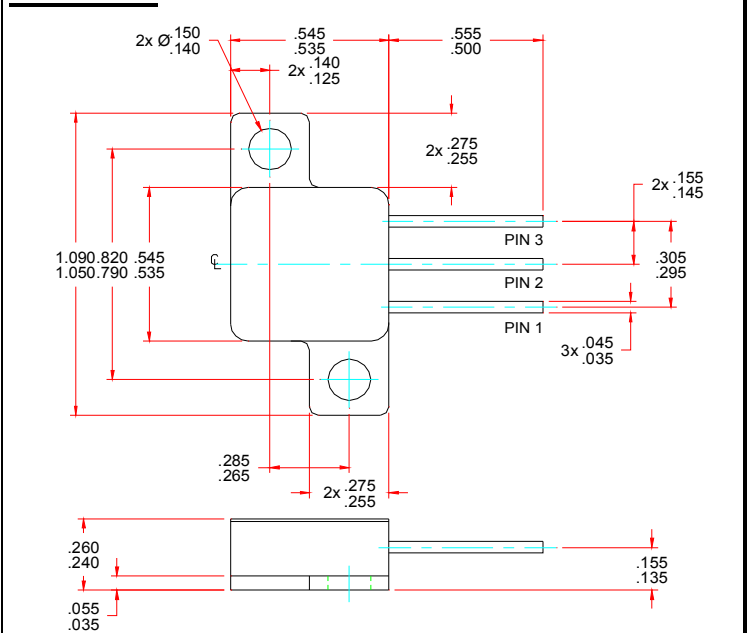

Optional Lead Bent Configuration

Down Bent (DB Suffix)

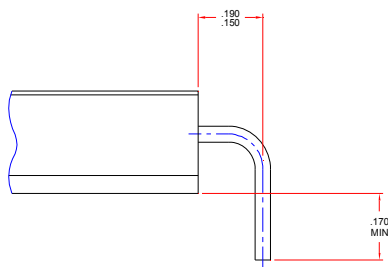

Up Bent (UB Suffix)

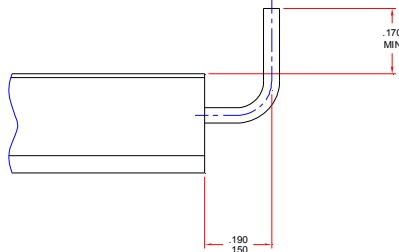

Pin Assignment

Code	Function	Pin 1	Pin 2	Pin 3
CT	Common Cathode	Anode	Cathode	Anode
CA	Common Anode	Cathode	Anode	Cathode
D	Doubler	Cathode	AC	Anode
DR	Doubler, Reverse	Anode	AC	Cathode

For information on curves, contact the Factory Representative for Engineering Assistance.

NOTE: All specifications are subject to change without notification. SCD's for these devices should be reviewed by SSDI prior to release.

DATA SHEET #: RC0027F

DOC