



Solid State Devices, Inc.

14701 Firestone Blvd * La Mirada, CA 90638
Phone: (562) 404-4474 * Fax: (562) 404-1773
ssdi@ssdi-power.com * www.ssdi-power.com

SRL2040 Series

**20 AMP
HYPER FAST RECTIFIER**
400 Volts
40 nsec

Designer's Data Sheet

Part Number / Ordering Information ^{1/}

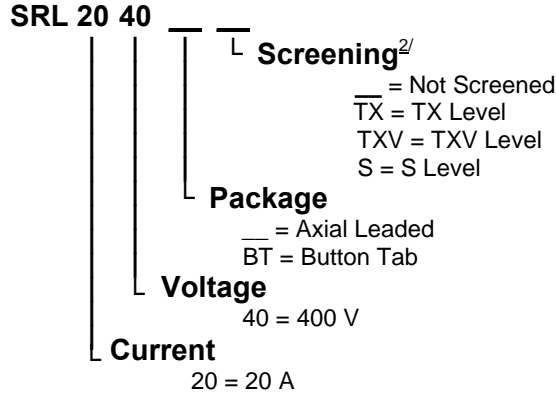

Features:

- Replaces JEDEC packages: TO-257, and TO-254
- Higher Current 20A vrs 8A, 12A, & 15 A
- Lower forward Voltage drop 1.30 V vrs 1.60 V
- Faster recovery time 40 nS vrs 60 nS
- Higher surge rating 350A vrs 60A, 125A, 140 A
- Lower thermal resistance 1.5 °C/W vrs 1.8 and 2.5 °C/W
- Hermetically sealed void-free construction^{3/}
- Higher voltages available - contact factory
- Surface mount replacement for 1N6766, 1N6772, 1N6778
- TX, TXV, and Space level screening available

MAXIMUM RATINGS	Symbol	Value	Units
Peak Repetitive Reverse Voltage and DC Blocking Voltage	V_{RRM} V_{RWM} V_R	400	Volts
Average Rectified Forward Current (Resistive load, 60Hz sine wave, $T_c=100^\circ\text{C}$, $T_L=-55^\circ\text{C}$)	I_O	20	Amps
Peak Surge Current (8.3 ms pulse, half sine wave superimposed on I_O , allow junction to reach equilibrium between pulses, $T_A=25^\circ\text{C}$)	I_{FSM}	350	Amps
Junction and Storage Temperature	T_J & T_{STG}	-65 to +175	°C
Maximum Thermal Resistance Junction to anode terminal	Axial @ 1/8" Button Tab $R_{\theta JC}$	6.0 1.5	°C/W

Notes:

- 1/ For ordering information, price, operating curves, and availability, contact factory.
- 2/ Screening based on MIL-PRF-19500. Screening flows available on request.
- 3/ PIND testing not required on void free devices per MIL-PRF-19500.

Axial Leaded (—)

SRL Button (BT)

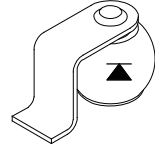
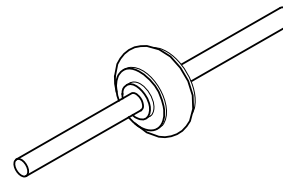

NOTE: All specifications are subject to change without notification. SCD's for these devices should be reviewed by SSDI prior to release.

DATA SHEET #: RC0156A

DOC



Solid State Devices, Inc.

14701 Firestone Blvd * La Mirada, CA 90638
 Phone: (562) 404-4474 * Fax: (562) 404-1773
 ssdi@ssdi-power.com * www.ssdi-power.com

SRL2040 Series

ELECTRICAL CHARACTERISTICS (T_a = 25 °C unless specified)	Symbol	Max	Unit
Instantaneous Forward Voltage Drop (I _F = 20A pulsed)	V _{F1}	1.4	V
Instantaneous Forward Voltage Drop (I _F = 20A pulsed, T _A = -65°C)	V _{F2}	1.6	V
Reverse Leakage Current (Rated V _R , pulsed)	I _{R1}	10	μA
Reverse Leakage Current (Rated V _R , pulsed, T _A = 100°C)	I _{R1}	1	mA
Breakdown Voltage (I _R = 100 μA)	BVR	400	V (min)
Junction Capacitance (V _R = 10 V _{DC} , f = 1MHz, T _A = 25°C)	C _J	100	pF
Reverse Recovery Time (I _F = 0.5A, I _R = 1.0 A, I _{RR} = 0.25A, T _A = 25°C)	t _{rr}	40	nsec

CASE OUTLINES: Axial Leaded ()

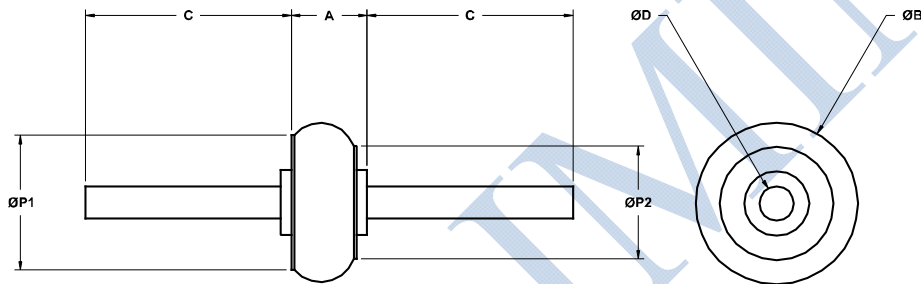

Dim	Min	Max
A	0.115"	0.135"
ØB	0.150"	0.190"
C	0.900"	—
ØD	0.038"	0.042"
ØP1	0.145"	0.155"
ØP2	0.125" REF	

CASE OUTLINES: Button (BT)

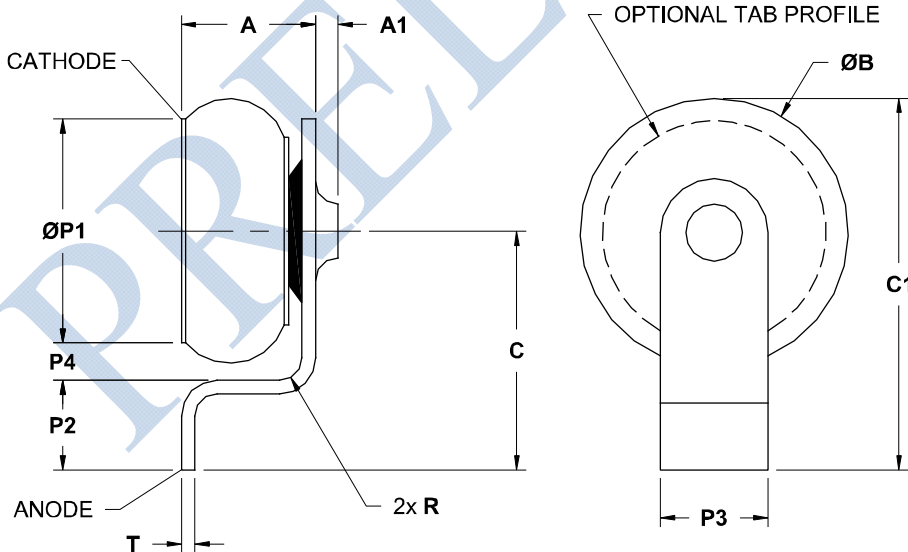

Dim	Min	Max
A	0.125"	0.150"
A1	—	0.020"
ØB	—	0.190"
C	0.190"	0.210"
C1	0.280" REF	
P1	0.145"	0.155"
P2	0.055"	0.075"
P3	0.090"	0.110"
P4	0.060" REF	
T	0.008"	0.012"
R	0.015" REF	

Notes:
 * Diode body profile may differ from the one shown for illustration
 **Dimensions prior to solder dipping

NOTE: All specifications are subject to change without notification. SCD's for these devices should be reviewed by SSDI prior to release.

DATA SHEET #: RC0156A

DOC