



SOLID STATE DEVICES, INC.

14830 Valley View Blvd * La Mirada, Ca 90638
Phone: (562) 404-7855 * Fax: (562) 404-1773
ssdi@ssdi-power.com * www.ssdi-power.com

Designer's Data Sheet

FEATURES:

- Available Voltages from 96V to 1600V. Consult Factory.
- Meets all Environmental Requirements of Mil-PRF-19500
- Custom Configurations Available
- Reverse Polarity Available (Add Suffix "R")
- 150°C Maximum Operating and Storage Temperature
- TX and TXV Level Screening Available

APPLICATIONS:

- Voltage Sensitive Components Protection
- Protection Against High Power Surges
- Lightning Protection

STM8057

120 kWATTS 840 VOLTS UNIDIRECTIONAL TRANSIENT VOLTAGE SUPPRESSOR

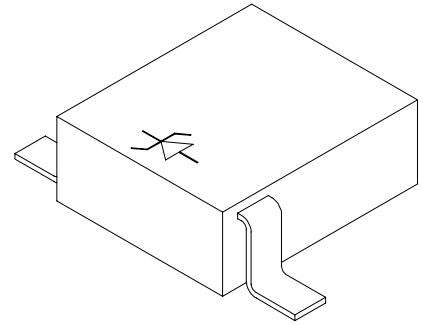

Maximum Ratings	SYMBOL	VALUE	UNITS
Peak Pulse Power Dissipation ^{2/}	P _D	120	kW
Stand off Voltage	V _{RWM}	800	V
Breakdown Voltage (Minimum)	V _{BR}	840	V
Clamping Voltage at I _{pp} ^{2/}	V _{CC}	1,000	V
Peak Current	I _{pp}	120	A
Operating and Storage Temperature	Top, Tstg	-65 to +150	°C

NOTE: All specifications are subject to change without notification. SCD's for these devices should be reviewed by SSDI prior to release.

DATA SHEET #: TVS002A

STM8057



SOLID STATE DEVICES, INC.

14830 Valley View Blvd * La Mirada, Ca 90638
 Phone: (562) 404-7855 * Fax: (562) 404-1773
 ssdi@ssdi-power.com * www.ssdi-power.com

Electrical Characteristics	SYMBOL	MIN	MAX	UNITS
Reverse Leakage Current ($V_{WM} = 800V$, $T_A = 25^\circ C$, 300 μsec pulse minimum)	IR1	-	100	μA
Reverse Leakage Current ($V_{WM} = 800V$, $T_A = 0^\circ C$, 300 μsec pulse minimum)	IR2	-	200	μA
Breakdown Voltage ($I_{BR} = 15mA$, $T_A = 25^\circ C$, 300 μsec pulse minimum)	VBR1	840	-	VDC
Breakdown Voltage ($I_{BR} = 15mA$, $T_A = 0^\circ C$, 300 μsec pulse minimum)	VBR2	810	-	VDC
Clamping Voltage ($I_{PP} = 120A_{(pk)}$, $t_R = 10\mu sec$, $t_p = 1000\mu sec$)	VC	-	1000	V(pk)

Package Outline:

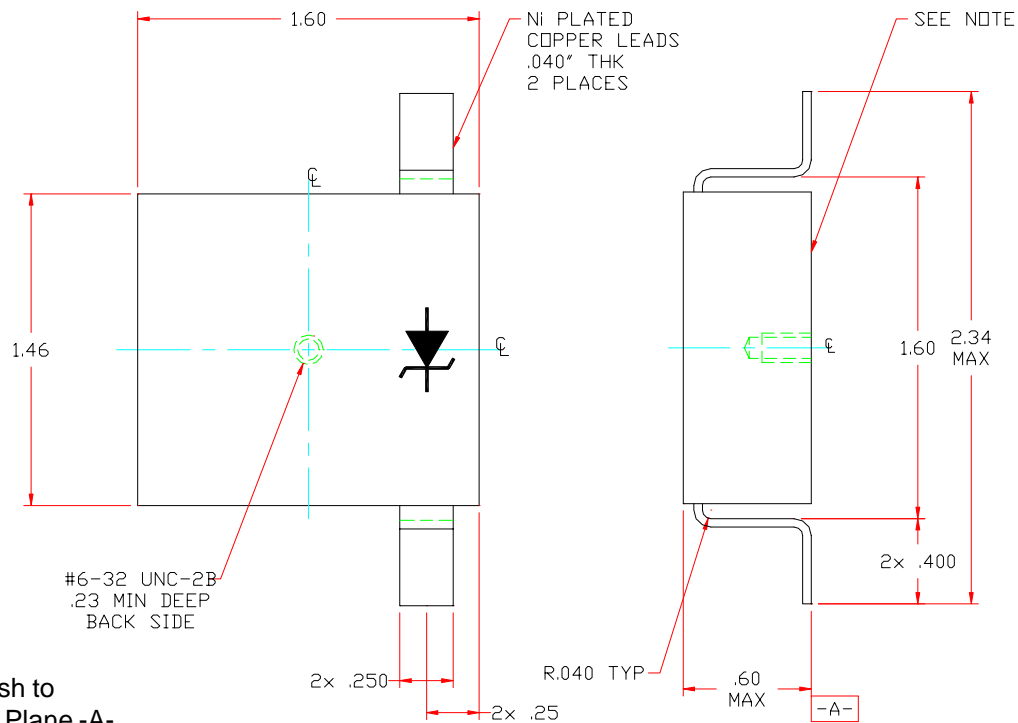

Note:

This Surface to be Flush to
 +.005" underflush with Plane -A-.

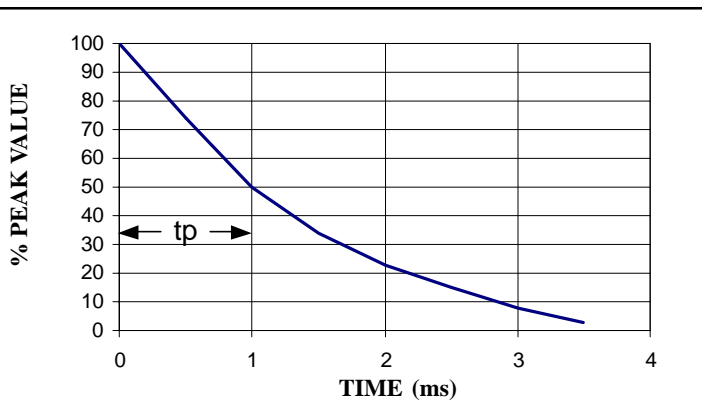

Notes:

1. All voltages are measured with automated test set using 35 msec test time. Longer or shorter test times will have a corresponding effect on the measured value due to the heating effects.
2. Current Pulse rises to peak value of I_{PP} in 10 μsec and decay to half value, $I_{PP}/2$, in 1msec.
3. Pulse width (t_p) is defined as the time from peak pulse current I_{PP} to the point where peak pulse current decayed to 50% of rated I_{PP} . (10 μsec x 100 μsec wave form as defined by R.E.A.)