



FEATURES:

- Suitable for RoHS reflow profile
- High current rating and low DCR
- Special lead wire design to prevent open circuit failure
- Excellent terminal strength to mechanical stress

APPLICATIONS:

- OA equipments
- PC and notebook
- LCD TV set
- Power supply

ELECTRICAL SPECIFICATIONS:

Abracon P/N:	ASPI-0302 Series
Operating Temperature:	-40°C to +85°C
Storage Temperature:	+5°C to +40°C

PART NUMBER	INDUCTANCE (uH)	Tolerance	DCR (Ω) max	IDC (A) max	Inductance Code
ASPI-0302-100	10	K	0.230	0.760	100
ASPI-0302-120	12	K	0.270	0.685	120
ASPI-0302-150	15	K	0.310	0.635	150
ASPI-0302-180	18	K	0.410	0.525	180
ASPI-0302-220	22	K	0.470	0.500	220
ASPI-0302-270	27	K	0.660	0.405	270
ASPI-0302-330	33	K	0.760	0.380	330
ASPI-0302-390	39	K	0.850	0.355	390
ASPI-0302-470	47	K	0.970	0.330	470
ASPI-0302-560	56	K	1.250	0.290	560
ASPI-0302-680	68	K	1.450	0.275	680
ASPI-0302-820	82	K	1.850	0.235	820
ASPI-0302-101	100	K	2.200	0.220	101
ASPI-0302-121	120	K	2.900	0.185	121
ASPI-0302-151	150	K	3.400	0.170	151
ASPI-0302-181	180	K	3.900	0.165	181
ASPI-0302-221	220	K	4.500	0.155	221
ASPI-0302-271	270	K	6.000	0.135	271
ASPI-0302-331	330	K	7.000	0.125	331
ASPI-0302-391	390	K	7.800	0.115	391

Test Conditions

Inductance: 100kHz

Isat: $\Delta L/L$ (initial) \geq -10% or $\Delta T=40^\circ\text{C}$ ($T_a=20^\circ\text{C}$), whichever is lower.

OPTIONS AND PART IDENTIFICATION

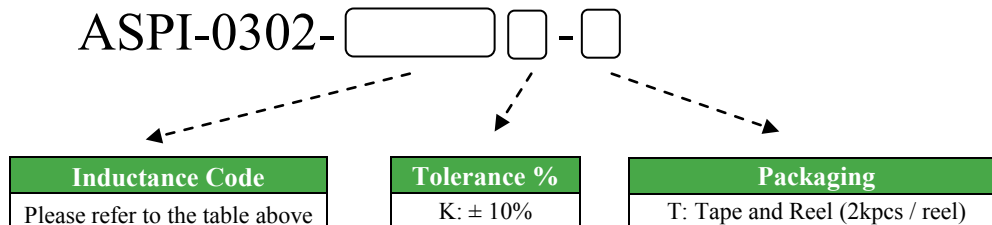



OUTLINE DRAWING:

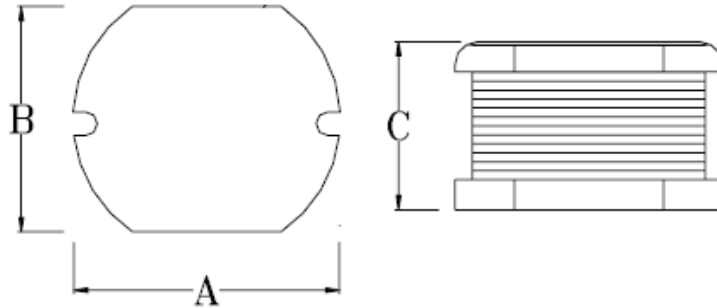

Recommended Land Pattern

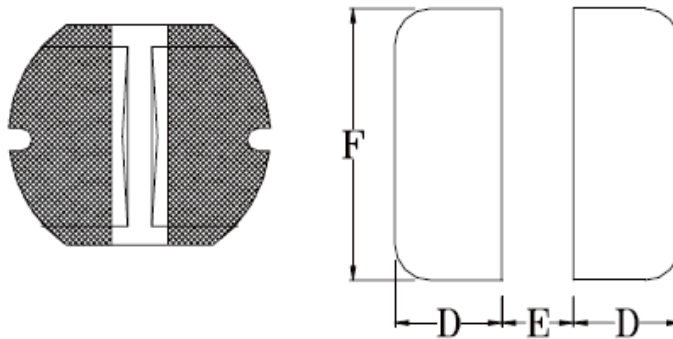

A	B	C	D	E	F
3.5±0.3	3.0±0.3	2.3±0.30	1.40	0.80	3.00

Dimension: mm

REFLOW PROFILE:

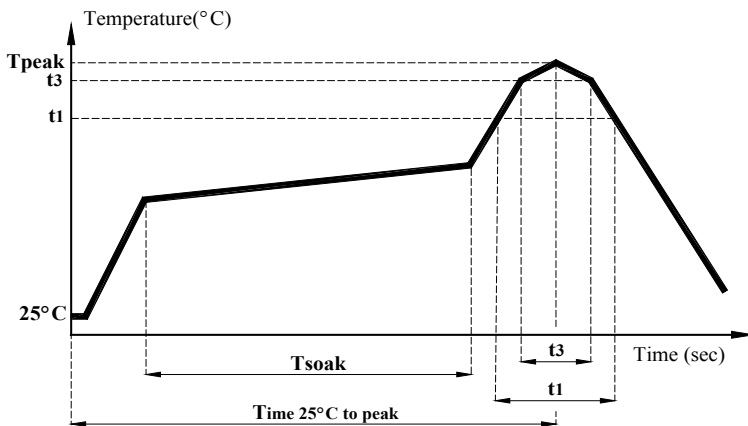

Item	mark	
Temperature rise gradient		3°C/sec (max)
Heating time	Tsoak	50s ~ 150s
Heating temperature		120°C~180°C
Time over 217°C	t1	70 sec
Time within 5°C of actual peak temperature	t3	10~30 sec
Peak temperature	Tpeak	250 (+0 / -5 °C)
Time 25°C to peak Temperature		6 minutes max.



TAPE & REEL:

T: 2,000pcs / reel

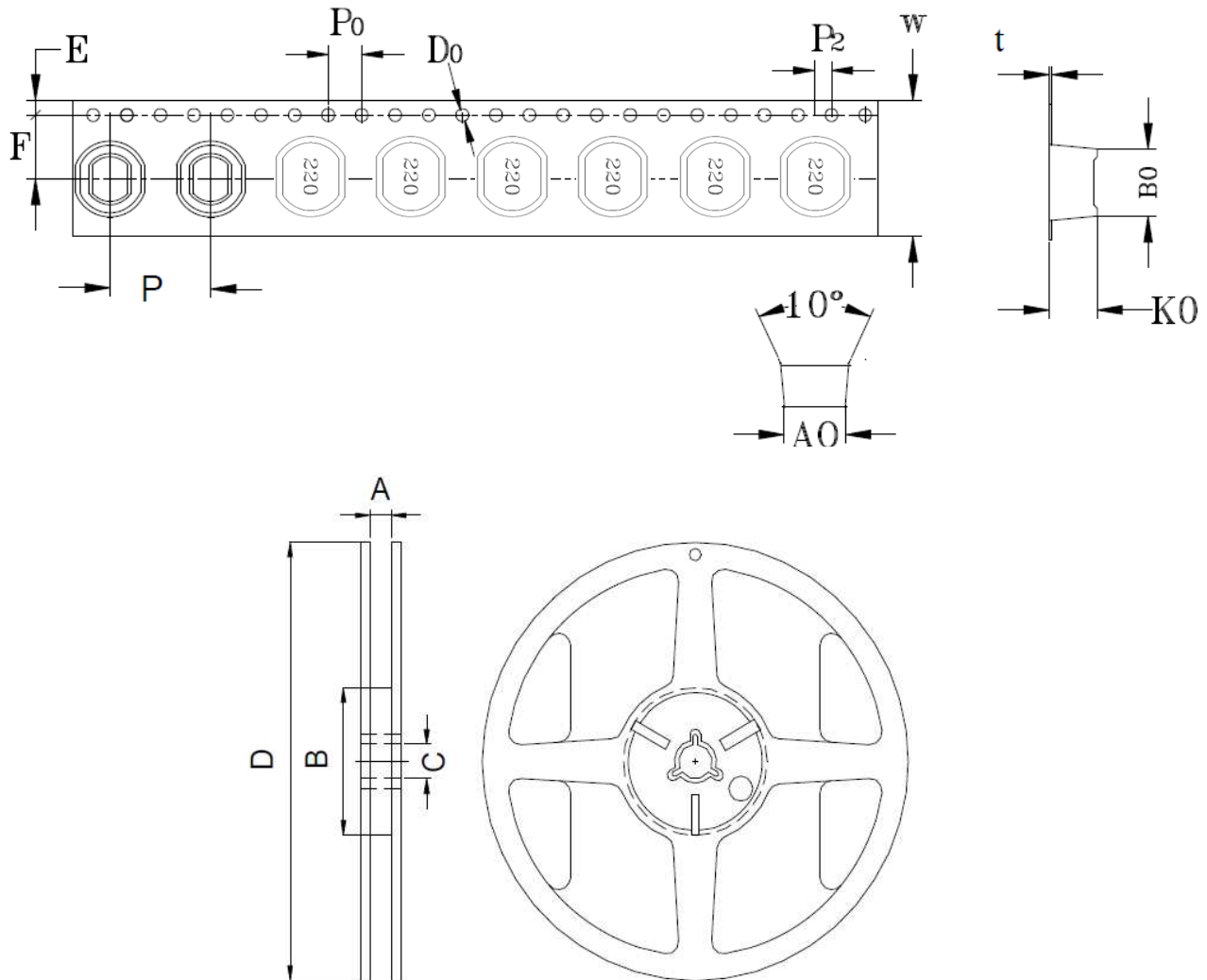

CARRIER TAPE / SIZE (mm)										REEL 13"×24mm			
A0	B0	K0	F	E	W	P	P ₀	P ₂	t	A	B	C	D
3.3 ± 0.1	3.8 ± 0.1	2.6 ± 0.1	5.5 ± 0.1	1.75 ± 0.1	12 ± 0.3	8 ± 0.1	4 ± 0.1	2 ± 0.1	0.35 ± 0.05	12.5 ± 0.5	100 ± 0.5	13.2 ± 0.3	330 ± 1.0

Dimension: mm

ATTENTION Abracon Corporation's products are COTS – Commercial-Off-The-Shelf products; suitable for Commercial, Industrial and, where designated, Automotive Applications. Abracon's products are not specifically designed for Military, Aviation, Aerospace, Life-dependant Medical applications or any application requiring high reliability where component failure could result in loss of life and/or property. For applications requiring high reliability and/or presenting an extreme operating environment, written consent and authorization from Abracon Corporation is required. Please contact Abracon Corporation for more information.