

Description

The **USB4** is a data acquisition device designed to record data from 4 incremental encoders, 8 digital inputs and 4 analog input channels. In addition, the **USB4** provides 8 digital outputs and 4 analog output channels. The 8 digital outputs also have a latching emergency stop (E-Stop) input. When the E-Stop input is activated, the 8 digital outputs will turn off immediately. The analog input/output channels provide 12-bit data conversions at rates up to 44 kHz per channel.

All communication between the **USB4** and the host PC is sent over a High-Speed USB 2.0 interface. The **USB4** is compatible with USB 2.0 hubs, allowing multiple **USB4** units to be used with a single PC. To handle continuous streaming of data over USB to the host PC, the **USB4** has a 32 Mbyte FIFO to buffer the captured data when the host PC or USB bus is busy. Note that 32 Mbyte FIFO functionality is only available with a High-Speed USB 2.0 connection.

The digital input port can handle input logic levels from +3V to +25V and the digital output port has open drain MOSFET outputs to switch up to 1A at +25V. The range of the analog input/output channels is 0V to +5V. Four independent, flexible, incremental encoder interfaces are implemented in hardware on the **USB4**. Each encoder channel has a 24-bit up/down counter that is easily reconfigured for various counting modes such as modulo-N, non-recycle, range-limit and normal counter mode. Quadrature input modes of x1, x2, x4, clock/direction, and indexing modes can also be selected. Each encoder channel can also measure the pulse width and pulse period of its "A" input while simultaneously decoding the quadrature state. This feature allows RPM speed measurements to be made from the encoder input or interfacing to sensors with PWM (pulse width modulated) outputs.

The **USB4** can capture data once per clock cycle of a user programmable 32-bit clock generator or on every rising or falling edge of the input port pins. Data capture can be programmed to run continuously or to start only when certain conditions are met such as the encoder count matching a certain value, or if there is encoder movement in a certain direction. Encoder events can also output on the output port to trigger external devices. Trigger conditions can also be set for the analog input and PWM input channels; in addition, the **USB4** can be configured to have the input port pins serve as a trigger to start data acquisition. The input port triggering is flexible and allows the user to form the final trigger from a combination of conditions on the input port with up to 2 levels of triggering. For example, trigger1 can be set to a rising edge of bit 0 and bit2, trigger2 can be set to a falling edge on bit3. Data capture will only start if...



Features

- Real-time tracking of up to 4 incremental encoders with or without index (up to 5 MHz encoder input frequency)
- 4 channel pulse width, pulse period and RPM measurement
- Available with single-ended or differential encoder inputs, optional DIN rail mounting
- 8 digital outputs, 8 digital inputs, 4 A/D inputs, 4 D/A outputs
- Flexible triggering modes and 32 Mbyte RAM buffer for data capture
- Programmable sampling period from 2 uS to approx. 2 hours
- Digital input levels up to +25V
- Digital outputs with open drain FET for up to 1A switching
- High-speed USB 2.0 interface with host PC
- Easy to use demo software, Windows DLLs for C/C++/Visual Basic and example source code provided

Description (Continued)

... occurs first, then trigger2.

All the software and documentation needed to use the **USB4** is available from US Digital. A PC demo application allows the user to configure and explore various features of the **USB4** using a graphical user interface. A library with a detailed Application Programming Interface is available so users can develop their own applications; additionally, US Digital provides several examples that demonstrate how to use the FIFO, how to log data, etc. For users that prefer lower level control, a documented register based interface is provided so the **USB4**'s internal registers can be configured at the bit level.

Software

- ▶ www.usdigital.com/support/software/usb4-software
- ▶ www.usdigital.com/assets/USDProducts.zip (.zip file with installer)

Mechanical Drawing

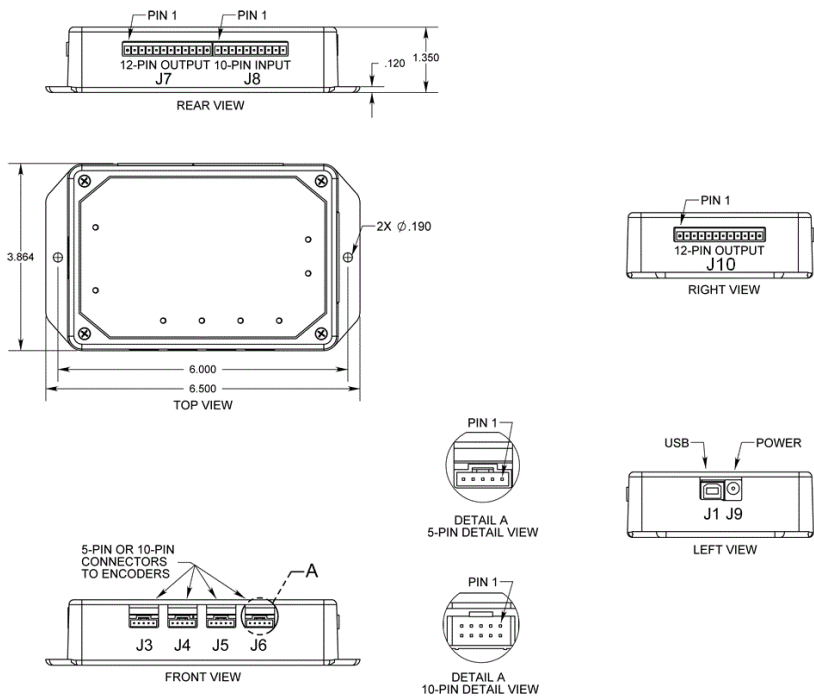

Environmental

Parameter	Min.	Max.	Units
Storage Temperature	-40	100	C
Operating Temperature	0	70	C
Relative Humidity (non-condensing)	0	95	%

Electrical

Parameter	Value
Supply Voltage	8V to 25V
Digital Output Pins	Open drain voltage, 25V max. Open drain sink current, 1A max.
Digital Input Pins	VIL(max) = 0.8V VIH(min) = 2.0V with approx. 100 mV of hysteresis VIH(max) = 24V
Analog Output Range	12-bit DAC, 0V to 5V
Analog Input Range	12-bit ADC, 0V to 5V
Power consumption	115 mA @ 8 V, 77 mA @ 12 V or 42 mA @ 24 V typical. (USB 2.0 connection, no encoders connected, all LED's off)
Max. current drawn from +5V outputs	550 mA (combined current of all +5 V output terminals on USB4)
Max. encoder input frequency	5 MHz
Max. FIFO write speed (Time Based Triggering)	500 kHz
Max. FIFO write speed (Event Based Triggering)	Counter - 200 kHz, Input Port - 100 kHz

Power Input

J9:

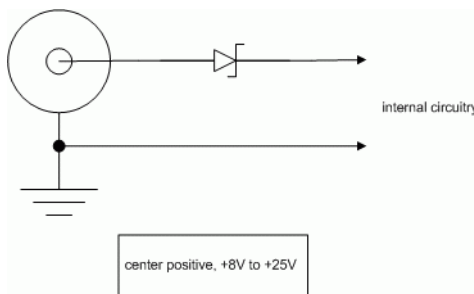

Single Ended Encoder Inputs

Encoder Channel 3,2,1,0 (J3, J4, J5, J6) Pin-out (USB4-S option):

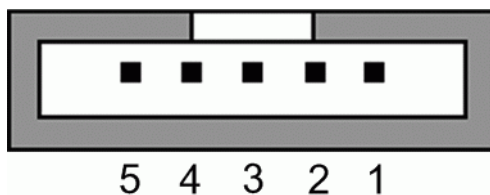

Pin Number	Description
1	Ground
2	Index
3	A Channel
4	+5V out
5	B channel

Single Ended input circuit (internal to USB4):

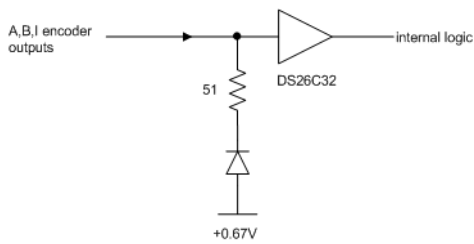

Differential Encoder Inputs

Encoder Channel 3,2,1,0 (J3, J4, J5, J6) Pin-out (USB4-D option):

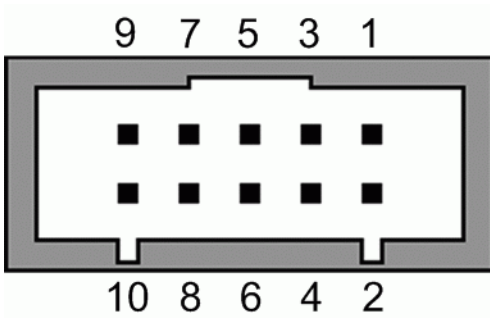

Pin Number	Description
1	No connection
2	Ground
3	Index-
4	Index+

Pin Number	Description
5	A- channel
6	A+ channel
7	+5V out
8	No connection
9	B- channel
10	B+ channel

Differential Input Circuit (internal to USB4):

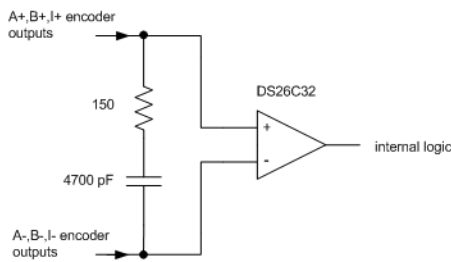

Digital Input Port

J8 Pin-out:

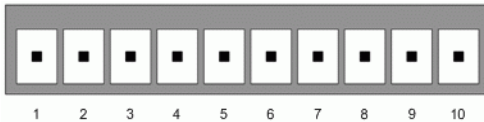

Pin Number	Description
1	+5V power out
2	Din0 (LSB)
3	Din1
4	Din2
5	Din3
6	Din4
7	Din5
8	Din6
9	Din7 (MSB)

Pin Number	Description
10	Ground

Input Port Circuit (internal to USB4):

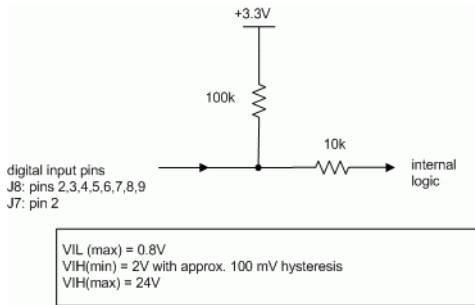

Digital Output Port

J7 Pin-out:

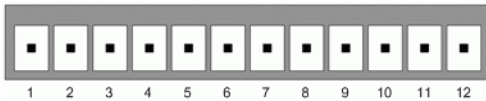

Pin Number	Description
1	+5V out
2	E-Stop input (active low)
3	Dout0 (LSB)
4	Dout1
5	Dout2
6	Dout3
7	Dout4
8	Dout5
9	Dout6
10	Dout7 (MSB)
11	Ground
12	Ground

Output Port Circuit (internal to USB4):

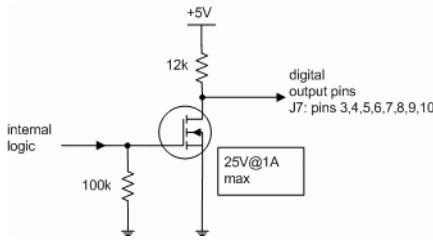

Note: When driving inductive loads, add an external reversed biased diode in parallel with the load to protect the USB4 from damage caused by large voltage transients.

Interface Port

J10 Pin-out:

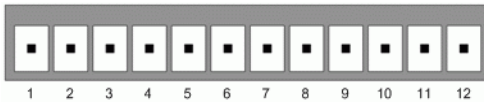

Pin Number	Description
1	+5V out
2	Reserved
3	Reserved
4	DAC0 (analog outputs)
5	DAC1
6	DAC2
7	DAC3
8	ADC0 (analog inputs)
9	ADC1
10	ADC2
11	ADC3
12	Ground

ADC Input Circuit (internal to USB4):

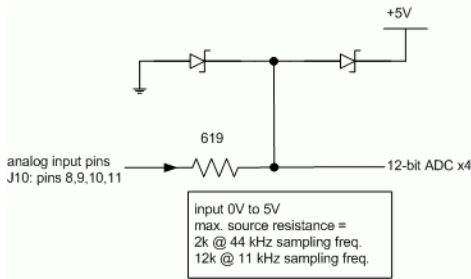

DAC Output Circuit:

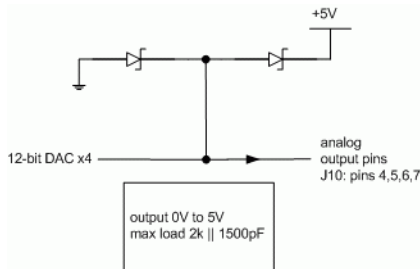

Included Accessories

PS-12 Power supply

Ordering Information

USB4 - -

Input	Mounting
<i>S = Single-ended</i>	<i>D = Default</i>
<i>D = Differential</i>	<i>R = DIN rail (35mm wide)</i>

Notes

- Cables and connectors are not included and must be ordered separately.
- US Digital warrants its products against defects in materials and workmanship for two years. See complete warranty for details.

Base Pricing

Quantity	Price
1	\$365.00
10	\$335.80

For volume discounts, please contact us at sales@usdigital.com or 800.736.0194.

- Add \$10.00 per unit for **Input** of Differential
- Add \$10.00 per unit for **Mounting** of DIN rail (35mm wide)