

Description

The USB1 is no longer available for purchase, and has been replaced by our recently released USB4 Encoder Data Acquisition USB Device. The USB4 is a redesigned, enhanced version of the USB1, and is already available for purchase.

The USB1 Encoder Data Acquisition Device has been replaced by our recently released USB4. The USB4 is a redesigned, enhanced version of the USB1, and is already available for purchase. The USB1 may still be purchased until its end of life (EOL) date, which is September 30, 2009.

The **USB1** is a data acquisition device designed to track up to 4 incremental encoders and 8 digital inputs. Each of the 4 external encoders has a dedicated 24-bit real-time hardware up / down counter. The internal microcontroller then reads and stores the value of all four counters, the 8 digital inputs, and a 32-bit time stamp at a rate configured by the user. This historical buffer can be downloaded to the PC using the USB interface at any convenient time, even while continuing to store more samples in the internal circular buffer. The **USB1** also includes the capability to use either encoder position changes or combinations of digital inputs as triggering and / or storage qualification events.

Eight relay driver type digital outputs are provided along with an SEI port that can read up to 15 US Digital absolute encoders per device. When a "1" is written a digital output port bit, the driver is asserted and the corresponding port pin is clamped to ground by a MOSFET transistor (it is an inverting "open-collector" configuration). The **USB1** takes advantage of the robustness, speed, and easy configurability of the Universal Serial Bus architecture while providing a simple and consistent software interface for the encoders and inputs that it tracks. The **USB1** is intended for use with computers that have at least one free USB port and are running the Windows 98/ME/2000/XP operating systems. The **USB1** is fully compatible with USB expansion hubs, allowing multiple **USB1** units to be used on a single computer.

The **USB1** is powered by a standard US Digital regulated DC power supply (PS-12). The **USB1** provides 5VDC power to the encoders and digital I / O connectors. The **USB1** may be instructed to retain configuration settings (but not count values) when power is removed. If power is lost, the incremental counters reset to zero.

The **USB1** supports both indexed and non-indexed encoders in x1, x2 or x4 counting modes. Its four independent counters are able to respond to quadrature frequency rates of up to 1 MHz, with a counting range from 0 to 16,777,215. The **USB1** command protocol provides access to a control register for each channel, allowing individually programmable count modes of Normal Count, Modulo-N, Non-recycle, and Range Limit...



Features

- Real-time tracking of up to four incremental encoders and 8 digital inputs
- History buffer has programmable sample frequency from once per day to 1 kHz
- DIN rail mounting is available
- 8 relay driver outputs
- 8 bit parallel input port accepts either relay closure, TTL input or high voltage input up to 30V
- LEDs show status of each encoder and bus activity
- Available with single-ended or differential encoder inputs
- Includes serial encoder interface (SEI) port for reading USD's absolute encoders
- Easy to use Windows drivers and demo software
- Low latency input capture mode: stores position within 25 usec of digital trigger input

Description (Continued)

... for each channel. The **USB1** may be configured in software to zero a channels counter when an encoder index signal is asserted.

The SEI port on the **USB1** is designed for US Digital's SEI based products, such as the A2 absolute encoder. The baud rate of the SEI port is fully programmable, and supports baud rates from 2400 to 57,600 bps.

Software

- www.usdigital.com/support/software/usb1
- www.usdigital.com/assets/USDProducts.zip (.zip file with installer)

Mechanical Drawing

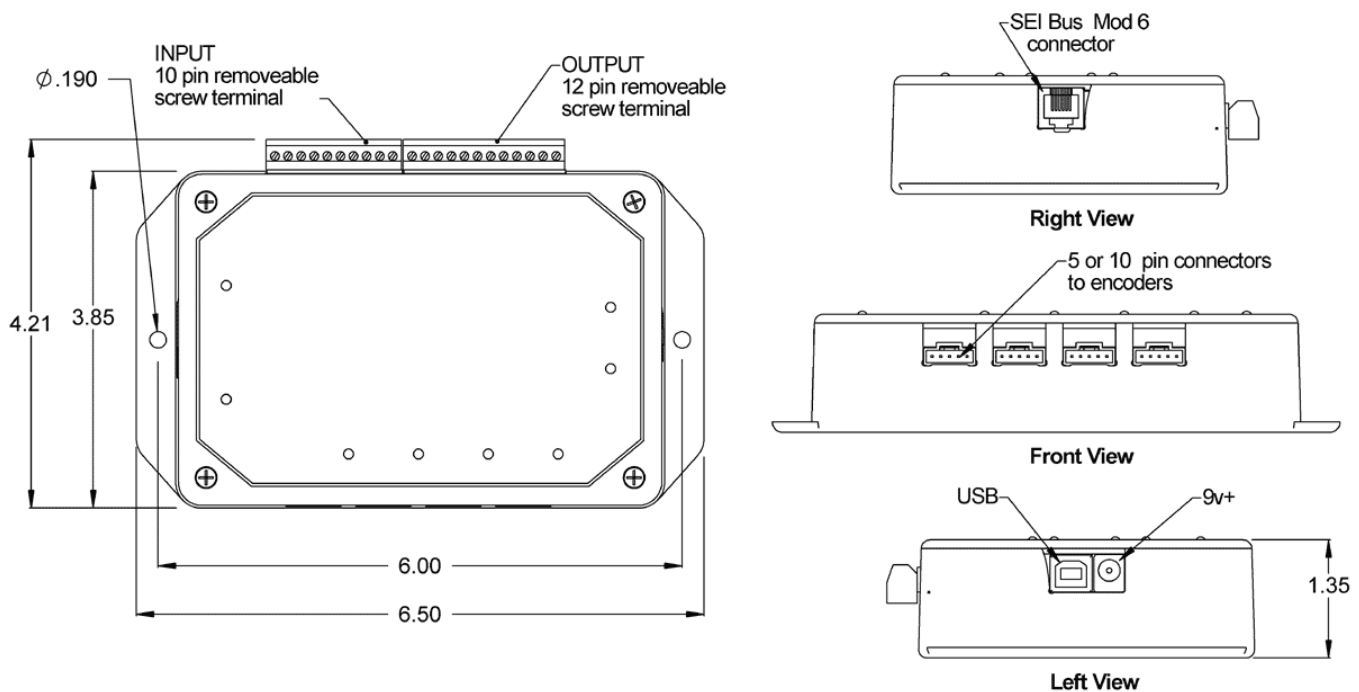

Hardware Specifications

Parameter	Min	Typ	Max	Units	Notes
Supply input voltage	8	12	16	V	Compatible with US Digital PS-12 power supply
Supply input current		50		mA	At 12 V with no encoders or I/O connected
Regulated output voltage for encoders and I/O	4.8		5.2	V	0 to 350 mA output current, 25C, 8 to 16 VDC supply
Open collector sink current, sum of Out0 through Out7			720	mA	Continuous, at 70 C
Open collector sink current, any single output			450	mA	Continuous, at 70 C

Open collector saturation voltage	0.5		V	Any single output, 100 mA sink current, 25 C
Open collector reverse current		500	mA	Continuous, at 25 C
TTL input port high level input voltage (Vih)	2.0	30	V	In0 through In7 are diode clamped to +5 V internal supply through a 10 k Ω resistor
TTL input port low level input voltage (Vil)	-0.5	0.8	V	In0 through In7 are diode clamped to ground through a 10 k Ω resistor
TTL input port high level input current		10	?A	
TTL input port low level input current		-500	?A	In0-In7 have 10 k Ω pull-up resistors to +5 V internal supply
Encoder input high level input voltage	2.0		V	Compatible with 5 V TTL optical encoders. See note 2
Encoder input low level input voltage (Vil)		0.8	V	Compatible with 5 V TTL optical encoders. See note 2
Encoder input, differential model, common mode voltage	-7	7	V	See note 3.
Encoder input, differential model, high level input current		0	mA	When driven by the TI 26C31 driver used in US Digital cable drivers
Encoder input, differential model, low level input current		2.7	mA	When driven by the TI 26C31 driver used in US Digital cable drivers
Encoder input, single-ended model, high level input current		-0.2	mA	When driven by HEDS or EM1 optical encoder module
Encoder input, single-ended model, low level input current		2.7	mA	When driven by HEDS or EM1 optical encoder module
Quadrature cycle input frequency	0	1.5	MHz	Maximum spec. requires software command to set. Default as shipped is 100 kHz
SEI port high level output voltage differential		4.75	V	
SEI port low level output voltage differential		0.1	V	
SEI port baud rates supported	2400	57.6k	baud	Default is 9600 baud
SEI port common-mode input voltage	-7.0	12	V	

Notes:

- The parallel output port is actually a MOSFET driver connected in an open-drain configuration; specifications have been translated and given in the more familiar open collector nomenclature. Note that setting a bit to 1 turns on a transistor to sink current to ground, and vice versa.
- Single-ended input model has encoder inputs that are terminated with 2.35 k Ω pull-up to +5 V, with a diode through 51 Ω to ground.
- Differential input model has encoder inputs that terminated with a 150 Ω resistor in series with 4.7 nF capacitor between each differential input pair.

Pin-outs

Pin	5-pin	10-in
1	Ground	Ground
2	Index	Ground
3	A channel	Index-
4	+5VDC power	Index+
5	B channel	A- channel
6		A+ channel
7		+5VDC power
8		+5VDC power
9		B- channel
10		B+ channel

Absolute Maximum Ratings

Parameter	Min.	Max.	Units
Storage Temperature	-40	100	C
Operating Temperature	0	70	C
Humidity (non-condensing)	0	95	%
Supply Voltage	8	16	V

USB1/USB4 Comparision

Features	USB1	USB4
8-bit output port with high current drive	yes	yes
8-bit input port (24V input compatible)	yes	yes
Real-time tracking of up to 4 incremental encoders	yes	yes
Multiple triggering modes	yes	yes
USB version	1.0	2.0 and 1.0
Sample FIFO Buffer for data logging	4.6K	800K
Time stamp update rate	10 kHz	48 MHz
Power Supply	8V to 16V	8V to 25V
4 channel 12-bit A/D converter	no	yes

4 channel 12-bit D/A converter	no	yes
Emergency stop input	no	yes
Pulse duration/frequency measurement on up to 4 channels	no	yes
A2 Absolute Encoder Interface	SEI port	no*
.ocx interrupt	yes	no*

* Contact customer support for alternative solutions

 **Included Accessories**

PS-12 Power Supply

Ordering Information

USB1 - -

Input	Mounting
<i>S = Single-ended</i>	<i>D = Default</i>
<i>D = Differential</i>	<i>R = DIN rail (35mm wide)</i>

Notes

- Cables and connectors are not included and must be ordered separately.
- US Digital warrants its products against defects in materials and workmanship for two years. See complete warranty for details.

Base Pricing

Quantity	Price
1	\$368.00
10	\$330.75

For volume discounts, please contact us at sales@usdigital.com or 800.736.0194.

- Add \$10.00 per unit for **Input** of Differential
- Add \$10.00 per unit for **Mounting** of DIN rail (35mm wide)