

## Description

The QSB is a low cost USB data acquisition device that can count quadrature and index signals from an incremental encoder, provide digital I/O, perform A/D conversion or act as a stepper/motor controller. There are 3 variants that provide a mix of different features.

- QSB-S - One single-ended quadrature, PWM or Analog encoder interface
- QSB-M - One single-ended quadrature, PWM or Analog encoder interface; 4-bits of digital I/O or 2-bits of digital I/O and 1 channel stepper motor control (step/direction)
- QSB-D - One differential quadrature encoder interface and 1-bit of digital I/O

The QSB is USB bus powered and is packaged in a slim, compact "stick" package that is easy to install and wire up. US Digital provides all the software and documentation needed to use the QSB. A PC demo application is available, allowing the user to configure and explore various features of the QSB using a graphical user interface. A library with a detailed Application Programming Interface is provided so that users can develop their own applications. Additionally, US Digital provides several examples that demonstrate how to use the device. For users that prefer lower level control, a documented register based interface is also provided. The QSB appears as a COM serial port to the PC, so any application that can read/write the COM port can be used to control the QSB as well.



## Features

- Low cost
- Easy to use USB serial port interface
- USB port powered
- Field upgradable software
- Reads Quadrature, PWM and Analog encoders
- Reads quadrature count rate up to 6 MHz
- Motor Step/Direction control outputs
- Four analog and four digital I/O pins
- RoHS compliant

 **Software**

- ▶ [www.usdigital.com/support/software/qsb-quadrature-to-usb-adapter-software](http://www.usdigital.com/support/software/qsb-quadrature-to-usb-adapter-software)
- ▶ [www.usdigital.com/assets/USDProducts.zip](http://www.usdigital.com/assets/USDProducts.zip) (.zip file with installer)

 **QSB-D, QSB-M, QSB-I**

QSB-D/M/I Quadrature to USB Adapter Drawing

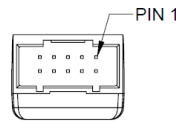
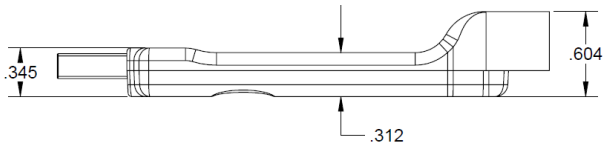
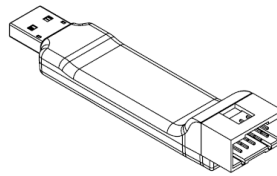
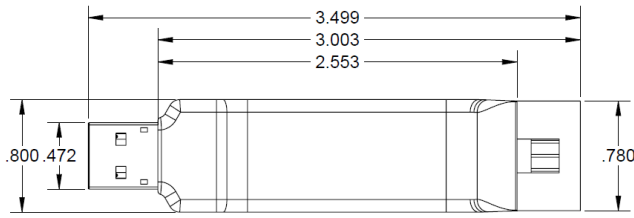

 **QSB-S**

QSB-S Quadrature to USB Adapter Drawing

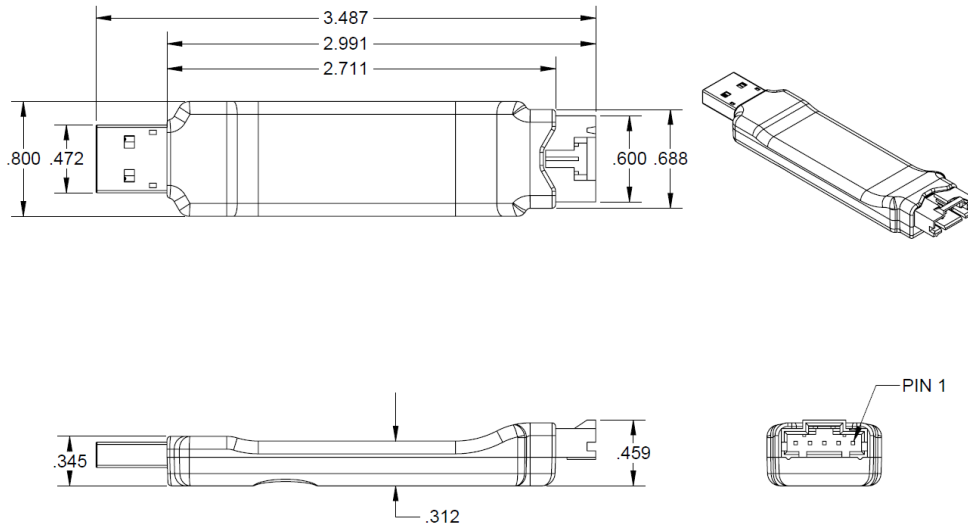

## Environmental

Parameter	Min.	Max.	Units
Storage Temperature	-40	100	C
Operating Temperature	0	70	C
Relative Humidity (non-condensing)	0	95	%

## Electrical

Parameter	Min.	Typ.	Max.	Units
Supply Voltage (Note 1)	4.75	5.00	5.25	V
Supply Current (QSB device only) (Note 2)		52		mA

Note 1: Voltage is regulated by USB port

Note 2: USB port capable of supplying 500mA maximum

## Pin-outs

### QSB-S Pinout

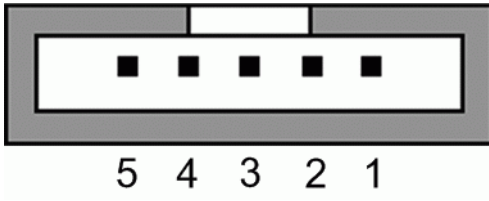

Pin	5-Pin Connector	USB
1	Ground	+5 Volts
2	Index	D-
3	A Channel or EAN0 or PWM0	D+
4	+5 Volts	Ground
5	B Channel	

Notes:

- › A/B/Index are the quadrature encoder signals
- › Pin 3 EAN0 is an A/D input designed for the MAE3-A10 and MA3-A10 analog output encoders. It can be used as a generic 10-bit A/D input (0-5V range).
- › Pin 3 PWM0 is a pulse width modulation input designed for the 10 or 12 bit PWM output of the MA3/MAE3 encoders.

QSB-D, QSB-M, QSB-I Pinout

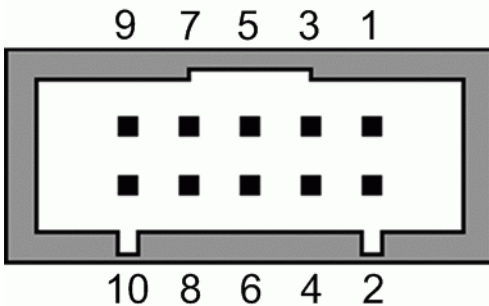

Pin	10-pin Connector QSB-D	10-pin Connector QSB-M	10-pin Connector QSB-I	USB Connector
1	Digital I/O Channel 0	Digital I/O Channel 0	Digital I/O Channel 0	+5 Volts
2	Ground	Ground	Ground	D-
3	Index-	Digital I/O Channel 1 or Motor Step	Digital I/O Channel 1 or Motor Step	D+
4	Index+	Index	Analog Input Channel 0	Ground

5	A-	Digital I/O Channel 2 or Motor Direction	Digital I/O Channel 2 or Motor Direction
6	A+ or EAN0 or PWM0	A or EAN0 or PWM0	Analog Input Channel 1
7	+5 Volts	+5 Volts	+5 Volts
8	No connection	+5 Volts	Analog Input Channel 2
9	B-	Digital I/O Channel 3	Digital I/O Channel 3
10	B+	B	Analog Input Channel 3

**Notes:**

- ▶ A/B/Index are the quadrature encoder signals
- ▶ Pin 6 EAN0 is an A/D input designed for the MAE3-A10 and MA3-A10 analog output encoders. It can be used as a generic 10-bit A/D input (0-5V range).
- ▶ Pin 6 PWM0 is a pulse width modulation input designed for the 10 or 12 bit PWM output of the MA3/MAE3 encoders.

**Encoder Interface (QSB-D, QSB-M, QSB-S only)**

Parameter	Min.	Typ. Max.	Units
Quadrature Encoder Input Frequency	0	6	MHz
PWM Encoder Input Frequency (Note 1)	250	1000	Hz
Encoder Single-Ended Interface			
Low Input	-1.0	2.1	V
High Input	2.8	7.0	V
Encoder Differential Interface			
Differential Voltage	200	7.0	mV
Common Mode Voltage	-7.0		V

Analog Encoder Input	0	5	V
Voltage Range	4.8	6.3	9.0
DC Input resistance (Note 2)			kOhm
Bandwidth	0		3000 Hz

Note 1: MA(E)3 PWM output frequency is 250 Hz for 12-bit and 1kHz for 10-bit resolution.

Note 2: Biased at approximately 2 V DC.

### Analog Input (QSB-I only)

Parameter	Min.	Typ.	Max.	Units
Analog Input Range	0		5	V
DC Input Resistance		94		kOhm
Analog input bandwidth		3000		Hz

### Digital I/O (all variants)

Parameter	Min.	Typ.	Max.	Units
Digital Input Voltage	0	5	24	V
Positive-going Input Voltage Threshold (Vin+)	1.5		2.5	V
Negative-going Input Voltage Threshold (Vin-)	0.83		1.82	V
Input Voltage Hysteresis (Vin+ - Vin-)	0.33		1.1	V
Digital High Output Voltage (Note 1)	4.75	5	5.25	V
Digital Low Output Voltage (Note 1)	0	0		V

Note 1: Output can be externally pulled up to 24V. Open drain MOSFET pulldown capable of 1.0 A max. continuous current. See digital output port circuits below. When driving inductive loads, add an external diode to protect the QSB from damage caused by large voltage transients.

Digital Input Port Circuit:

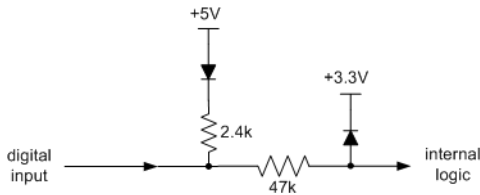

Digital Output Port Circuit:

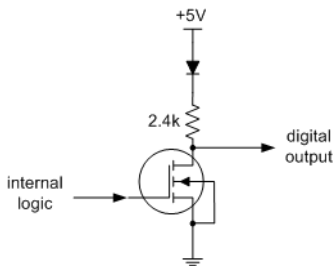

## Stepper motor control (QSB-M, QSB-I only)

The speed and direction of a single stepper motor can be controlled using the QSB-M or QSB-I in conjunction with a stepper motor driver, such as the US Digital MD2S. Two of the four digital I/O port pins can be configured to have motor step/direction functionality or normal digital I/O.

See the "QSB Command List" document for detailed information on the QSB's motor control commands.

## Command Interface

### QSB Commands

#### Command Format:

Commands are sent to the QSB in the format seen in the table below. All commands are composed of a string of ASCII characters terminated by an EOC (end of command) sequence. The first field in the command string selects the Command Type; there are three types of commands ? Read, Write and Stream. Registers, within the QSB, are configured to support different functions. The second field, the Register field, selects the register to read or modify. The Data field holds the value for the selected register. The EOC field is a command termination sequence. The commands are sent in RS-232 format over a virtual COM port connection through the USB. The data rate is 230.4KB, 8 data bits, no parity, 1 stop bit, no flow control. The RTS line must be held low and the DTR line must be held high for normal operation. The QSB can be reset with a high-low-high transition on the DTR line. NOTE: a backspace character will erase the partially entered command from the command buffer; this is useful when entering commands manually from a terminal.

Command Type[1]	Register[2]	<Data[1..8]>	EOC[1..2]
-----------------	-------------	--------------	-----------

Where:

- "Command Type" is a single upper-case ASCII character indicating an ?R?=read, ?W?=write ?S?=Streaming read.

- ▶ "Register" is the index number (see below) of the register being addressed. Range is 00 to FF (two upper or lower case ASCII bytes representing a single hex byte)
- ▶ "Data" is the optional value to be written to the selected register (eight ASCII hex bytes representing four hex bytes, 00000000 to FFFFFFFF). All data entered, less than 8 bytes in length, will be internally converted to a positive signed long value. Negative values must be entered as a full 4 bytes in two's-complement format.
- ▶ "EOC" is a one to two-byte ASCII character sequence indicating the end of command. The command termination is any single or dual combination of CR and LF characters.

**Command Acknowledgement Format:**

All commands will be acknowledged. For read commands, the Data will be the requested register value. For write commands, the returned Data value will be the data received. For example, the response to a MODE register "Quadrature Mode" write command will be the ASCII string "w", "00", "00000000", "!", followed by the EOR sequence. At the conclusion of the command response, the QSB is ready to accept another command.

Command Response[1]	Register[2]	Data[8]	<TimeStamp[8]>	!	EOR[1..2]
---------------------	-------------	---------	----------------	---	-----------

**Where:**

- ▶ "Command Response" is a single lower-case ASCII character indicating the Command Type of the last command. An r=read, w=write, s=stream, e=error, x=unsupported command.
- ▶ "Register" is the index number of the register in the last command. Range is 00 to FF (two ASCII bytes representing a single hex byte).
- ▶ "Data" is the value written to, or read from, the selected register (eight ASCII hex bytes representing four hex bytes, 00000000 to FFFFFFFF). Returned data will have added leading 0's to fill the entire eight bytes. If the error response is returned, Data will be the incorrect data value sent to the QSB; this value was not written to the device.
- ▶ "TimeStamp" is the optional timestamp value recorded at the time the data was read. (eight ASCII hex bytes representing four hex bytes, 00000000 to FFFFFFFF). The timestamp represents the number of counts of a 1.9ms internal clock since the last counter reset or power-up time. The value will roll-over if not reset by a user command.
- ▶ "EOR" is the End-Of-Response termination format selected using the EOR TERMINATION register (see below). It could consist of No Termination, CR, LF, TimeStamp or space delimited formatting. No space delimiter precedes the EOR character.

See the QSB Command List document for detailed information on the QSB commands.

**Software Field Upgrade**

The QSB firmware can be easily upgraded using the "QSB Firmware Updater" program that is available on the QSB Software page. There may be periodic upgrades to the QSB firmware that can be loaded as needed by a customer. The firmware upgrades typically take less than 30 seconds.

## Ordering Information

QSB -

**Options**

S = *Single Ended*

D = *Differential & I/O*

M = *Single Ended & I/O*

**Notes**

- Cables and connectors are not included and must be ordered separately.
- US Digital warrants its products against defects in materials and workmanship for two years. See complete warranty for details.

## Base Pricing

Quantity	Price
1	\$44.95
10	\$40.50

For volume discounts, please contact us at sales@usdigital.com or 800.736.0194.

- Add 22% per unit for **Options** of Differential & I/O or Single Ended & I/O