

Description

The PCI-3E does not support Windows 7 Operating System. Please see our USB4 interface product which is Windows 7 compatible.

The **PCI-3E** is a PCI interface card that will track up to three incremental encoders and has an I/O port capable of handling four digital inputs and four digital outputs. Multiple cards can be used concurrently on the same PCI bus of a PC to obtain additional channels. Each encoder channel has a 24-bit real time up/down counter with a count range from 0 to 16,777,215.

The **PCI-4E** is available for applications where four incremental encoders and no I/O port are desired (see the PCI-4E page).

The **PCI-3E** provides four fast and efficient up / down counting modes for real-time data acquisition applications. These include modulo-N, non-recycle, range-limit and simple 24 bit counter mode. Quadrature input modes of x1, x2, x4 and pulse/direction can be selected. The on-board FIFO buffer stores up to 204 data records. Each record which consists of three encoder counts, a 4-bit input port reading and a 32-bit time stamp.

Time based data logging allows encoder data to be logged with precise intervals. Wide ranges of sampling periods can be programmed up to 128,849 seconds in 30 μ s increments. A console application written in C (a tight loop program using no interrupts) running on a PC with a 1.8GHz processor and Windows 2000 may potentially store up to 150,000 samples per second to a data array, each sample consists of the three 24-bit encoder position counters and a 33 MHz time stamp. Due to how Microsoft Windows handles CPU time and processes, the sampling rate may periodically drop.

The output pins can be programmed to send out user defined values or send out trigger outputs of encoder channels. The input pins can be used for digital reading of user programs or programmed to detect signal edges (rising or falling) for capturing encoder counts and a time stamp.

Two versions are available: the single-ended **PCI-3E-S** for TTL encoder inputs or the differential **PCI-3E-D** for RS-422 encoder inputs.

The plug-and-play software automatically detects the existence of one or more **PCI-3E** cards on the PCI bus and assigns a unique device ID to each card. Demo software is available for Windows 2000/XP. The software displays the position of each encoder and allows the user to change the parameters of each channel individually. This demo software includes the source code and provides a good starting point for the development of user customizable software. LabVIEW users are also provided with the LabVIEW driver software and application.

Download the PCI-3E User Manual.



Features

- ▶ up to 4 million encoder cycles per second (up to 16 million quadrature states per second)
- ▶ Handles 3 encoder channels with index
- ▶ 4-bit digital input port and 4-bit open-drain MOSFET output port
- ▶ Provides 33 MHz timestamp
- ▶ Preloadable up/down 24 bit counters
- ▶ Supports trigger event interrupts and FIFO half-full interrupts
- ▶ x1, x2, x4 resolution multipliers
- ▶ Independent mode programmability for each channel
- ▶ Available with single-ended or differential encoder inputs
- ▶ 32-bit programmable sampling period with 30 microsec. resolution

 **Software**

- ▶ www.usdigital.com/support/software/pci-3e
- ▶ www.usdigital.com/assets/USDProducts.zip (.zip file with installer)

 **Mechanical Drawing**

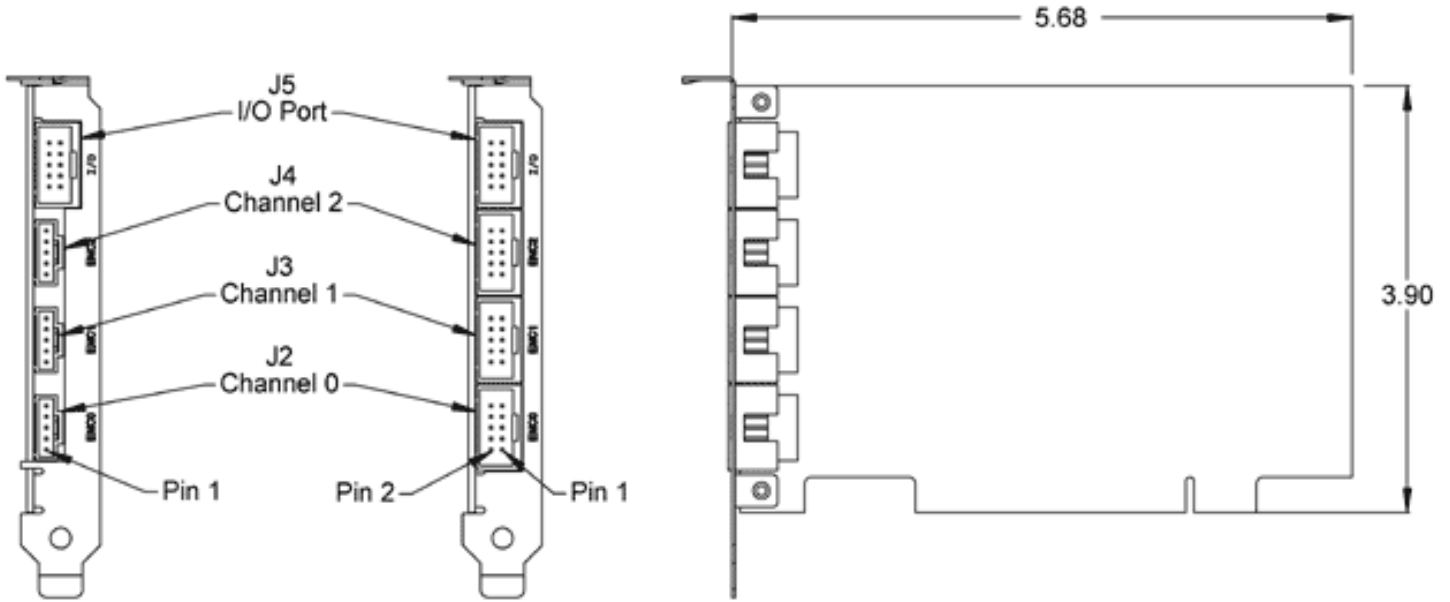

 **Environmental**

Parameter	Min.	Max.	Units
Storage Temperature	-40	100	C
Operating Temperature	0	70	C
Humidity (non-condensing)	0	95	%

 **Encoder Channel Electrical**

Parameter	Min.	Max.	Units
Encoder Voltage (+5 from PCI bus)	4.75	5.25	V
Encoder Input Frequency (cycles per second)	-	4	MHz
Encoder Input Frequency (quadrature codes per second)	-	16	MHz
Current (+5V consumed by card)	-	135	mA
Current (+5V current available for each encoder)	-	190	mA
Current (+5V total current available for all encoders)	-	570	mA

I/O Port Electrical

Parameter	Min.	Typ.	Max.	Units	Notes
Input Pin, Positive-going Threshold (VT+)	1.2	1.5	1.9	V	Vcc = 4.5V @ 25C
Input Pin, Positive-going Threshold (VT+)	1.4	1.7	2.1	V	Vcc = 5.5V @ 25C
Input Pin, Negative-going Threshold (VT-)	0.5	0.9	1.2	V	Vcc = 4.5V @ 25C
Input Pin, Negative-going Threshold (VT-)	0.6	1.0	1.4	V	Vcc = 5.5V @ 25C
Input Pin, Minimum Input Pulse Width	3.0	-	-	?s	See note 1
Output Pin, Open Drain Voltage	-	-	24	V	See note 2
Output Pin, Open Drain Sink Current	-	-	2.0	A	

Notes

- › Pulses with less than 1.9 ?s width are considered noises and rejected by digital filters.
- › Clamped to ground with 25V transient voltage suppressor against ESD.

Encoder Channel Pin-outs (J2 / J3 / J4)

Single Ended Input (PCI-3E-S)

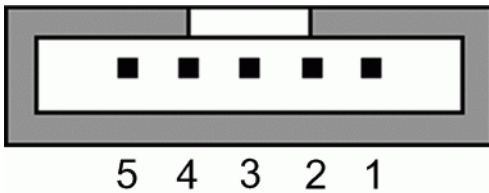

Pin	Description
1	Ground
2	Index
3	A channel
4	+5VDC power
5	B channel

Differential Input (PCI-3E-D)

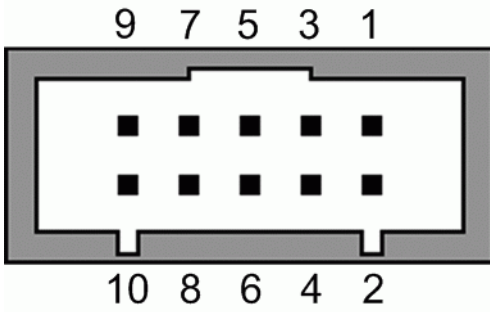

Pin Number	Description
1	No connection
2	Ground
3	Index-
4	Index+
5	A- channel
6	A+ channel
7	+5V out
8	No connection
9	B- channel
10	B+ channel

I/O Port Pin-out (J5)

10-pin:

Pin	Description
1	OUT0
2	GND
3	OUT1
4	IN0
5	OUT2
6	IN1
7	+5VDC Pullup Voltage*
8	IN2
9	OUT3
10	IN3

* Connected to +5VDC via a 100 Ohm current limiting resistor. This resistor protects an encoder accidentally connected to the I/O port. See I/O Port Circuit Diagram below.

Encoder Channel Input Circuit (J2 / J3 / J4)

Single-ended

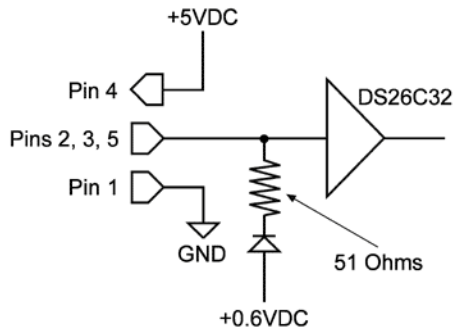

Differential

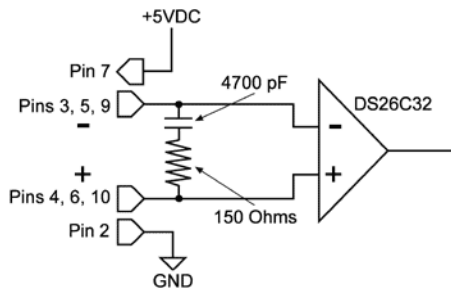

I/O Port Circuit (J5)

Input Pins

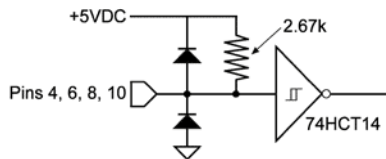

Output Pins

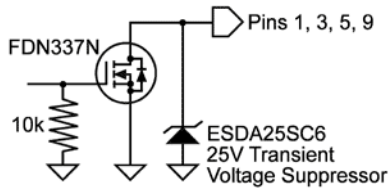

Power & Ground Pins

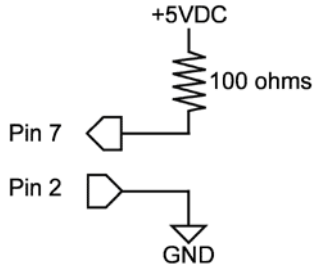

 Product Change Notifications

Title	Date	Description	Download
EOL - PCI-3E - PCN1035	7/17/2013	This PCN is a formal notification that US Digital is discontinuing the PCI-3E.	Download

Ordering Information

PCI-3E -

Input

S = *Single-ended*

D = *Differential*

Notes

- ▶ US Digital warrants its products against defects in materials and workmanship for two years. See complete warranty for details.

Base Pricing

Quantity	Price
1	\$368.00
10	\$330.75
50	\$299.25

For volume discounts, please contact us at sales@usdigital.com or 800.736.0194.

- ▶ Add \$10.00 per unit for **Input** of Differential