

Description

The **MAE3** is an absolute magnetic kit encoder that provides shaft position information over 360 ° of rotation with no stops or gaps. This magnetic encoder is designed to easily mount to, and dismount from, an existing shaft to provide digital feedback information. The **MAE3** is available with an analog or a pulse width modulated (PWM) digital output.

Analog output provides an analog voltage that is proportional to the absolute shaft position. Analog output is only available in 10-bit resolution.

PWM output provides a pulse width duty cycle that is proportional to the absolute shaft position. PWM output is available in 10-bit and 12-bit resolutions. While the accuracy is the same for both encoders the 12-bit version provides higher resolution.

The **MAE3** consists of three components: base, push-on magnetic hub, and encoder body. The base will accommodate 0.750", 1.280" and 1.812" mounting bolt circles. No tools are needed for the push-on, collet gripping hub. The hub mounts to a standard shaft in seconds and provides a simple and reliable means of securing the magnet to the shaft.

Two 4-40 pan head screws secure the base and encoder body to any flat surface. If desired, the encoder can be powered up and rotated by hand to any desired absolute position before the screws are tightened.

Connecting to the **MAE3** is simple. The 3-pin, high retention, snap-in 1.25mm pitch polarized connector provides for +5V, output, and ground.



Features

- ▶ Quick, simple assembly and disassembly
- ▶ -40C to +125C operating temperature
- ▶ Accepts ± .025" axial shaft play
- ▶ Mounts to 0.750", 1.280" and 1.812" bolt circles
- ▶ Fits shaft diameters from .125" to .250" or 2mm to 6mm
- ▶ 10-bit Analog output - 2.6 kHz sampling rate
- ▶ 10-bit PWM output - 1024 positions per revolution, 1 kHz
- ▶ 12-bit PWM output - 4096 positions per revolution, 250 Hz

Size 18 Bolt Circle

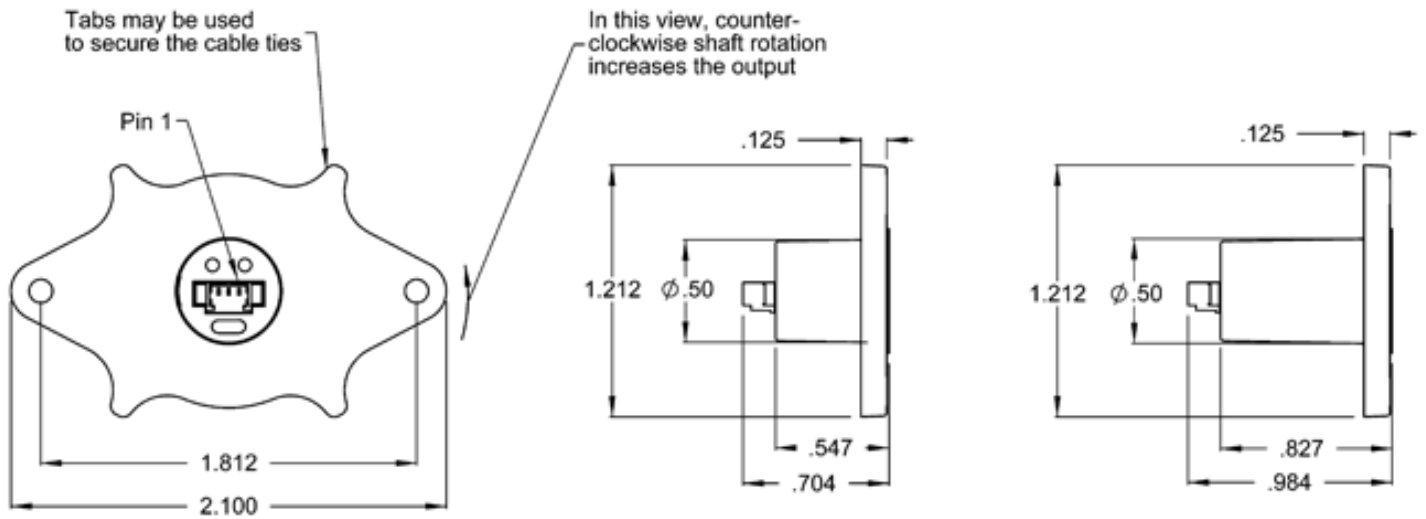

Size 12 Bolt Circle

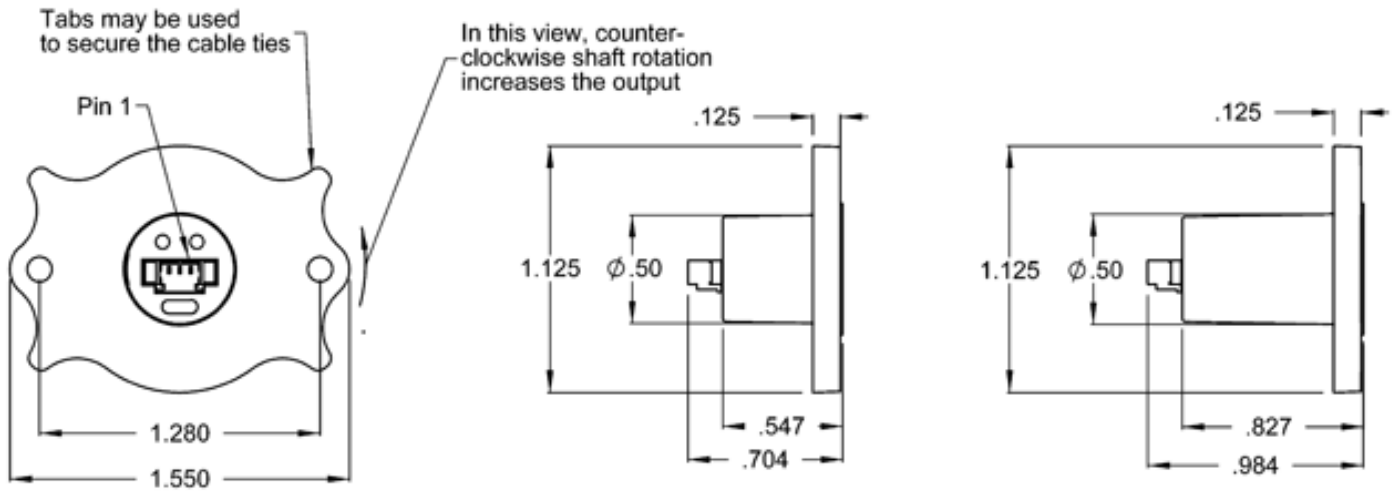

 **Size 7 Bolt Circle**

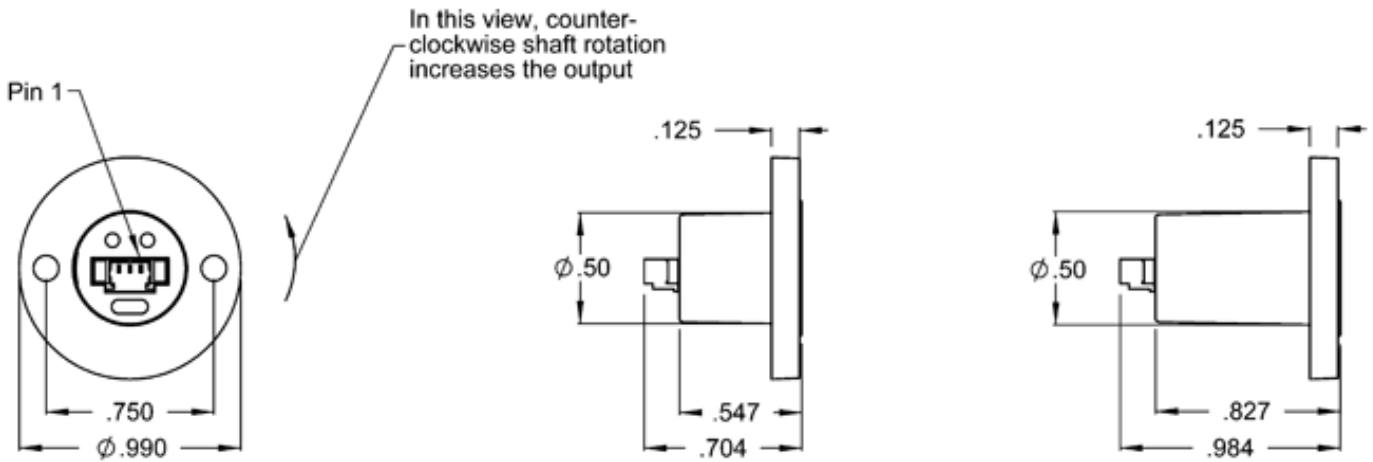

 **Environmental**

Parameter	Value
Operating Temperature	-40C to +125C
Storage Temperature	-55C to +125C
Humidity, Non-condensing	5% to 85%
Vibration (5Hz to 2kHz)	20G.
Electrostatic Discharge, Human Body Model	± 2 kV

 **Mechanical**

Parameter	Value	Units
Max. Shaft Axial Play	±0.025	in.
Max. Shaft Eccentricity Plus Radial Play (1)	0.004	in.
Max. Acceleration	250000	rad/sec ²
Angular Accuracy, 25C (2)	≤ 0.5	deg.
Angular Accuracy, -40C to 125C (2)	≤ 0.9	deg.
Moment of Inertia	8.49 x 10 ⁻⁷	oz-in-s ²
Mounting Screw Size (pan head)	4-40 x 1/4"	-
2 Screw Bolt Circle Diameter	.750 ± .005	in.
2 Screw Bolt Circle Diameter	1.280 ± .005	in.
2 Screw Bolt Circle Diameter	1.812 ± .005	in.

Parameter	Value	Units
Required Shaft Length (including axial play)		
Size 220 Shaft Length -option	0.220 (+0.015 / -0.020)	in.
Size 500 Shaft Length -option	0.500 (+0.015 / -0.020)	in.
Base to Mounting Surface Torque	4 - 6	in-lbs
Shaft diameter tolerance, relative to nominal	-0.0001 to -0.0006	in.
Technical Bulletin TB1001 - Shaft and Bore Tolerances		Download

(1) For optimum accuracy, the magnetic hub must be fully seated on the shaft and centered with respect to the mounting holes. Motor shaft length (including axial play) must fall within -.020" to +.015" of nominal and shaft runout must be ≤ 0.005 "

(2) Radial play larger than the specified maximum will result in angular errors beyond the specified limits. There is no maximum RPM. However, there will be fewer readings per revolution as the speed increases. The formula for number of readings per revolution is given by:

$$n = (60 / (\text{rpm} * 96 \text{ usec}))$$

Electrical

Parameter	Min.	Typ.	Max.	Units
Power Supply	4.5	5.0	5.5	Volts
Supply Current	-	16	20	mA
Power-up Time	-	-	50	mS

Analog Output Operation

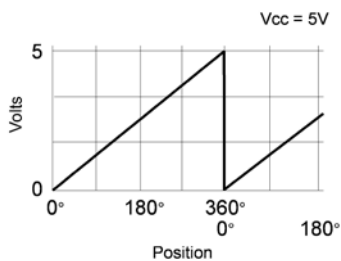

Analog output is only available in 10-bit resolution. The analog output voltage is ratiometric to the power supply voltage and will typically swing within 15 millivolts of the power supply rails with no output load. This non-linearity near the rails increases with increasing output loads. For this reason, the output load impedance should be $\geq 4.7k\Omega$ and less than 100pF. The graphs below show the typical output levels for various output loads when powered by a 5V supply.

Parameter	Min.	Typ.	Max.	Units
Position Sampling Rate	2.35	2.61	2.87	kHz
Propagation Delay	-	-	384	?S

Parameter	Min.	Typ.	Max.	Units
Analog Output Voltage Maximum (1)	-	4.987	-	Volts
Analog Output Voltage Minimum (1)	-	0.015	-	Volts
Output Short Circuit Sink Current (2)	-	32	50	mA
Output Short Circuit Source Current (2)	-	36	66	mA
Output Noise (2)	160	220	490	μ Vrms
Output Transition Noise (3)	-	0.03	-	Deg. RMS

(1) With no output load. See graphs below.

(2) Continuous short to +5V or ground will not damage the MAE3.

(3) Transition noise is the jitter in the transition between two adjacent position steps.

Output Voltage vs. Output Load w/ Pulldown Resistors to GND

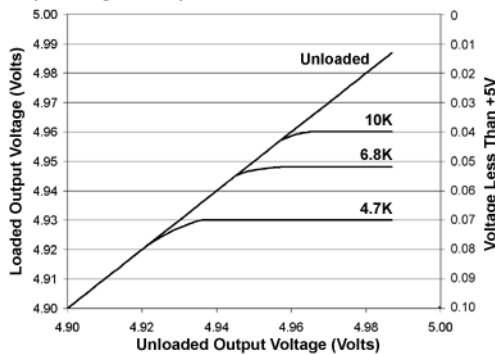

Output Voltage vs. Output Load w/ Pullup Resistors to +5V

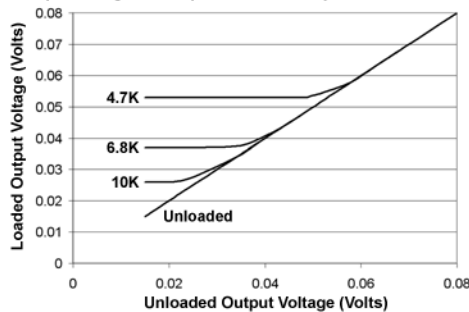

PWM Output Operation

The magnetic sensor chip in the MAE3 has an on-chip RC oscillator which is factory trimmed to 5% accuracy at room temperature (10% over full temperature range). This tolerance influences the sampling rate and the pulse period of the PWM output. If only the PWM pulse width t_{on} and nominal pulse period is used to measure the angle, the resulting value also has this timing tolerance. However, this tolerance can be cancelled by measuring both t_{on} and t_{off} and calculating the angle from the duty cycle.

Parameter	Min.	Typ.	Max.	Units
-----------	------	------	------	-------

PWM Frequency (-40C to 125C)				
10-bit	0.877	0.975	1.072	kHz
12-bit	220	244	268	Hz
Minimum Pulse Width				
10-bit	0.95	1.00	1.05	?S
12-bit	0.95	1.00	1.05	?S
Maximum Pulse Width				
10-bit	974	1025	1076	?S
12-bit	3892	4097	4302	?S
Internal Sampling Rate				
10-bit	9.38	10.42	11.46	kHz
12-bit	2.35	2.61	2.87	kHz
Propagation Delay				
10-bit	-	-	48	?S
12-bit	-	-	384	?S
Output Transition Noise, 12-bit version (1)		.03		Deg. RMS
Output Transition Noise, 10-bit version (1)		.12		Deg. RMS
Output High Voltage (VOH: @4mA Source) (2)		Vcc -0.5	-	V
Output Low Voltage (VOL: @4mA Sink) (2)		-	0.4	V

(1) Transition noise is the jitter in the transition between two adjacent position steps.

(2) Continuous short to +5V or ground will not damage the MAE3.

10-bit PWM:

$$x = ((t_{on} * 1026) / (t_{on} + t_{off})) - 1$$

If $x \leq 1022$, then Position = x

If $x = 1024$ then Position = 1023

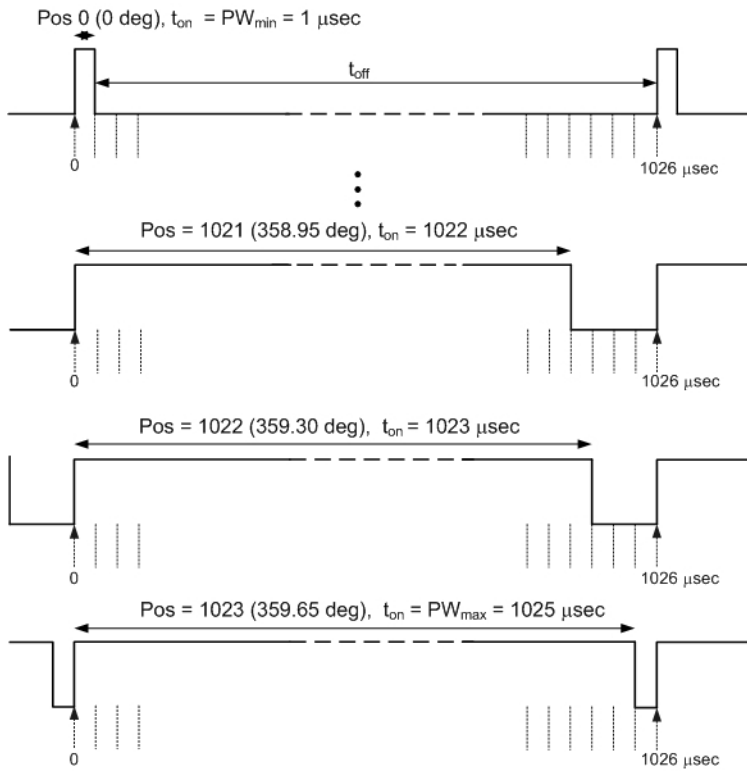

12-bit PWM:

$$x = ((t_{on} * 4098) / (t_{on} + t_{off})) - 1$$

If $x \leq 4094$, then Position = x

If $x = 4096$ then Position = 4095

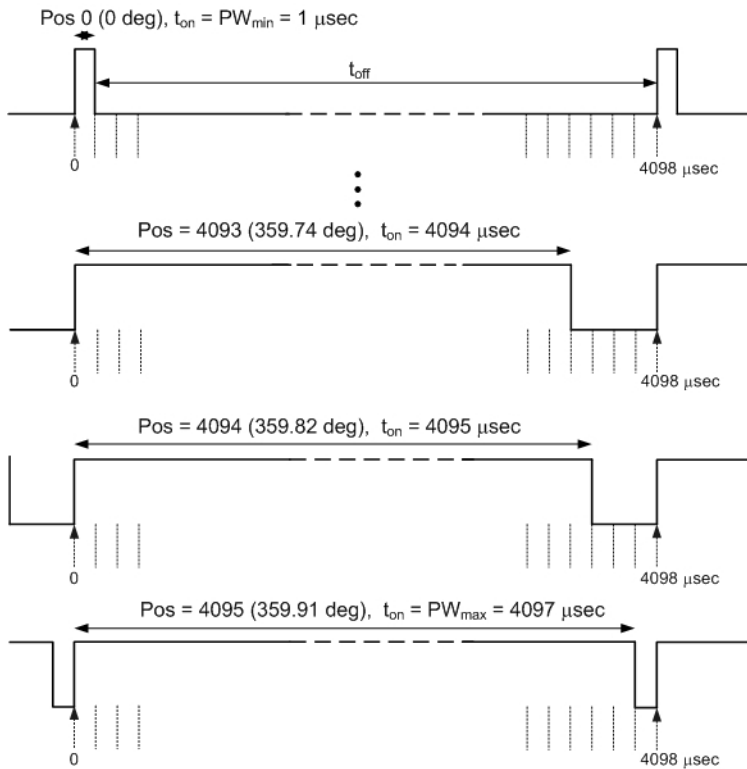

Pin-outs

Analog Output (MAE3-A):

Pin	Name	Description
1	5	+5VDC power
2	A	Analog output
3	G	Ground

PWM Output (MAE3-P10, MAE3-P12):

Pin	Name	Description
1	5	+5VDC power
2	A	PWM output
3	G	Ground

Accessories

Screws

Part #:	SCREW-440-250-PH
Description:	4-40 x 1/4" Pan head screw
Quantity Required for Mounting	2 per encoder

Assembly Instructions

MAE3 Assembly Instructions - <http://usdigital.com/assets/general/MAE3%20Assembly%20Instructions.pdf>