

## Description

The HB5M is a hollow bore (hollow shaft / thru-bore) optical encoder with a machined aluminum enclosure and a clear anodized protective finish. The HB5M optical incremental encoder is designed to easily mount to an existing shaft to provide digital feedback information for any motion control application. The HB6M has a compliant mounting method that makes it more tolerant of radial and axial shaft runout than a standard kit encoder.

Typical applications include servo motor feedback, web process control, robotics, flux vector feedback, high power motors, textile machines and elevator controls.

The HB5M bearing style encoder features a hollow bore that accepts shaft diameters of 5mm to 8mm in diameter. The encoder slips over the shaft and is locked into place with two 4-48 set screws. A flexible anti-rotation tether compensates for shaft run out of up to 0.030" axial and 0.010" TIR. The flexible tether provides mounting for two 4-40 machine screws on a 1.812" bolt circle.

The HB5M housing comes standard with a closed cover to limit particle ingress, or an optional hole in the body to allow a shaft to pass completely through the encoder.

The mating connector is polarized and latches into the encoder. Depressing the latch tab allows the connector to be unplugged. Mating connector assemblies are available from US Digital stock. Custom cables are also readily available (see the Cables / Connectors page).

The differential version has an internal differential line driver (26C31) attached to the encoder module that can source and sink 20mA at TTL levels. The cable that connects to this encoder should have 3 twisted pairs for the data channels plus power and ground. Group each pair of differential signals. The recommended receiver is industry standard 26C32. Maximum noise immunity is achieved when the differential receiver is terminated with a 150  $\Omega$  resistor in series with a 0.0047  $\mu$  f capacitor placed across each differential pair. The capacitor simply conserves power; otherwise power consumption would increase by 20mA per pair, or 60mA for 3 pairs.

## Mechanical Drawing



## Features

- ▶ Hollow bore (hollow shaft / thru-bore) bearing design
- ▶ Rugged anodized aluminum housing
- ▶ Heavy duty ball bearings track up to 6,000 RPM
- ▶ Positive finger-latching polarized connector
- ▶ 2-channel quadrature, TTL squarewave outputs
- ▶ 3rd channel index option
- ▶ Differential line driver output option
- ▶ 32 to 1250 cycles per revolution (CPR)
- ▶ 124 to 5000 pulses per revolution (PPR)

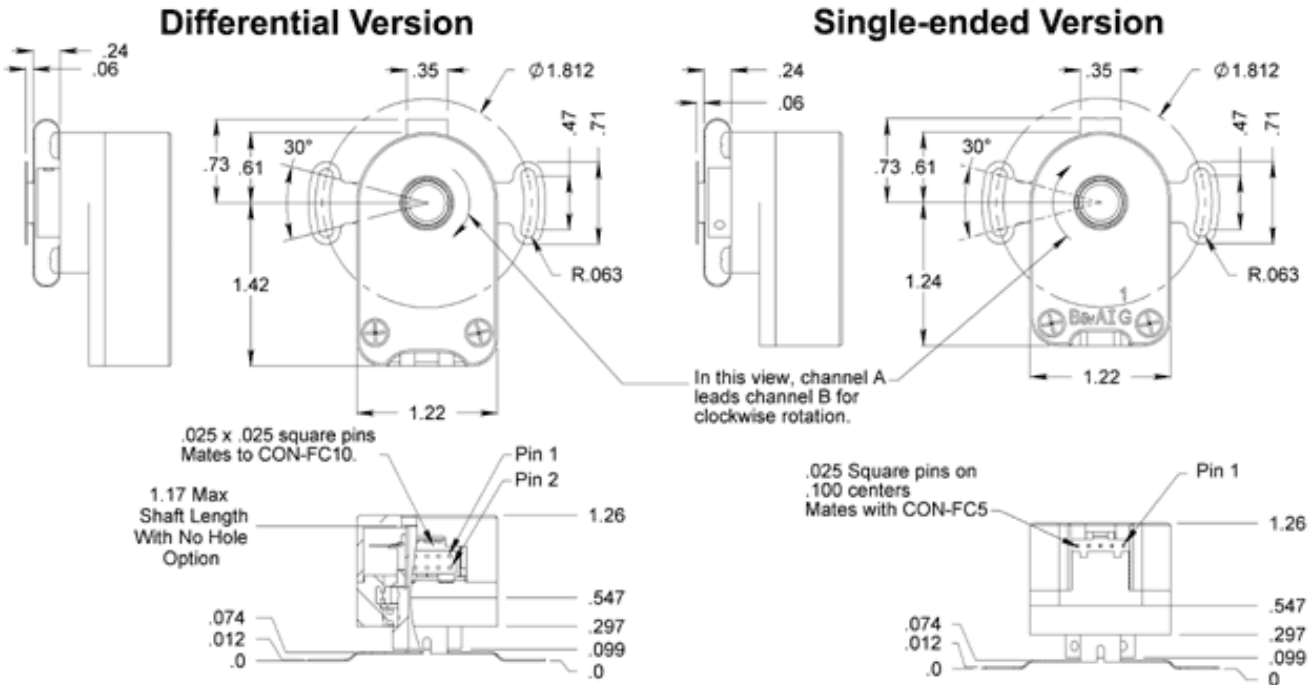

### Environmental

Parameter	Value	Units
Operating Temperature	-40 to 100	C
Vibration (5Hz to 2kHz)	20	G
Shock, 11 mSec	50	G
Electrostatic Discharge, Human Body Model	± 4	kV

### Mechanical

Parameter	Value
Max. Acceleration	100000 rad/sec <sup>2</sup>
Max. Shaft Speed	6000 rpm
Max. Starting Torque	0.20 oz-in
Max. Bore Load	2 lb.
Weight	2.84 oz.
Max. Shaft Total Indicated Runout	0.010 in.
Max. Shaft Axial Play	± 0.030 in.
Max. Shaft Insertion Depth	1.0 in. with default cover. No limit with H-option cover.

Moment of Inertia

1.29 x 10<sup>-4</sup> oz-in-sec<sup>2</sup>

Technical Bulletin TB1001 - Shaft and Bore Tolerances

[Download](#)

### Phase Relationship

A leads B in a clockwise shaft rotation, and B leads A in counterclockwise shaft rotation viewed from the rear side (opposite flexible mount) of the encoder.

### Single-ended Electrical

- Specifications apply over entire operating temperature range.
- Typical values are specified at Vcc = 5.0Vdc and 25 ° C.
- For complete details, see the EM1 product page.

Parameter	Min.	Typ.	Max.	Units	Conditions
Supply Voltage	4.5	5.0	5.5	V	
Supply Current		27	33	mA	CPR < 500, no load
		50	62	mA	CPR ≥ 500, no load
Low-level Output			0.5	V	IOL = 8mA max.
High-level Output	2.0			V	IOH = -8mA max.
	4.2	4.8		V	no load
Output Current Per Channel	-8		8	mA	
Output Rise Time		110		nS	
Output Fall Time		35		nS	

### Differential Electrical

- Specifications apply over entire operating temperature range.
- Typical values are specified at Vcc = 5.0Vdc and 25 ° C.
- For complete details, see the EM1 product page.

Parameter	Min.	Typ.	Max.	Units	Conditions
Supply Voltage	4.5	5.0	5.5	V	
Supply Current		29	36	mA	CPR < 500, no load
		57	65	mA	CPR ≥ 500, no load
Low-level Output		0.2	0.4	V	IOL = 20mA max.
High-level Output	2.4	3.4		V	IOH = -20mA max.
Differential Output Rise/Fall Time			15	nS	

### Pin-outs

#### 5-pin Single-ended:

Pin	Description
1	Ground
2	Index
3	A channel
4	+5VDC power
5	B channel

#### 10-pin Differential

Pin	Description
1	Ground
2	Ground
3	Index-
4	Index+
5	A- channel
6	A+ channel
7	+5VDC power
8	+5VDC power
9	B- channel
10	B+ channel

### Product Change Notifications

Title	Date	Description	Download
		As part of US Digital's continual assurance of supply strategy, we have qualified additional sources for our LED die used in our EM1 encoder module, which in turn impacts all of the following products:	<a href="#">Download</a>
EM1 LED Die - PCN 1016	2/7/2013	EM1, E2, E3, E5, E6, H1, H15, H3, H5, H6, HB5M, HB6M, HD25, PE, S1, S2, S5, S6, T5 and T6  The device specification will remain the same, i.e. there will be no change to form, fit or function of the product(s) as specified by US Digital. The appropriate quality and reliability testing has been performed on representative products to ensure normal parametric distribution, consistent with US Digital's quality and reliability standards.	

EM1 Component  
Change Notice

N/A

Unless otherwise specified, the US Digital EM1 optical encoder module will be phased in to replace our previous encoder module, HEDS-9000 Series, supplied by Avago Technologies. [View](#)

### Ordering Information

HB5M -	<input type="text"/>	-	<input type="text"/>	-	<input type="text"/>	-	<input type="text"/>	-	<input type="text"/>
	<b>CPR</b>		<b>Bore</b>		<b>Index</b>		<b>Output</b>		<b>Housing</b>
	32 =		197 =5mm		NE =No Index		S =Single-ended		D =Default
	50 =		236 =6mm		IE =Index		D =Differential		H =Hole in Housing
	96 =		250 =1/4"						
	100 =		313 =5/16"						
	192 =		315 =8mm						
	200 =								
	250 =								
	256 =								
	360 =								
	400 =								
	500 =								
	512 =								
	540 =								
	720 =								
	900 =								
	1000 =								
	1024 =								
	1250 =								

### Rules

- Index must be equal to NE when CPR is equal to 32

### Notes

- Cables and connectors are not included and must be ordered separately.
- For ordering information please see the Compatible Cables / Connectors section above.
- US Digital warrants its products against defects in materials and workmanship for two years. See complete warranty for details.

### Base Pricing

Quantity	Price
1	\$164.00
10	\$147.00

For volume discounts, please contact us at [sales@usdigital.com](mailto:sales@usdigital.com) or 800.736.0194.

- ▶ Add 8% per unit for **Output** of Differential
- ▶ Add 6% per unit for **Index** of IE or **CPR** greater than or equal to 1000.