

Description

The **H15** series ball bearing optical shaft encoder has a servo mount size 15 machine aluminum flange with a molded polycarbonate housing. This non-contacting rotary to digital converter is designed for applications requiring a size 15 servo mount. The **H15** utilizes either a 5-pin or 10-pin finger-latching connector depending upon the encoder output option.

The **H15** is fully assembled with a shaft, two 1/4" ID by 1/2" OD heavy duty ball bearings and a servo mount adapter. The shaft is made of stainless steel. The **H15** may be mounted and held in position by either attaching to the 4-40 machine screw holes in the base or by using the attached servo ring and separate servo cleats (see Accessories on the next page).

The single-ended output version is normally designed for applications of 10 feet or less. For longer cable lengths, the differential output version is recommended.

A secure connection to the **H15** is made through a 5-pin (single-ended versions) or 10-pin (differential versions) finger-latching connector (sold separately). The mating connectors are available from US Digital with several cable options and lengths.

For differential versions: the internal differential line driver (26C31) can source and sink 20mA at TTL levels. The recommended receiver is industry standard 26C32. Maximum noise immunity is achieved when the differential receiver is terminated with a 150 Ω resistor in series with a .0047 μ F capacitor placed across each differential pair. The capacitor simply conserves power; otherwise power consumption would increase by approximately 20mA per pair, or 60mA for 3 pairs.



Features

- Industry standard size 15 mounting
- 2-channel quadrature, TTL squarewave outputs
- Optional index (3rd channel)
- Differential outputs available
- Positive finger-latching connector
- 32 to 1250 cycles per revolution (CPR)
- 128 to 5000 pulses per revolution (PPR)
- -40 to +100C operating temperature
- Single +5VDC supply

Single-Ended

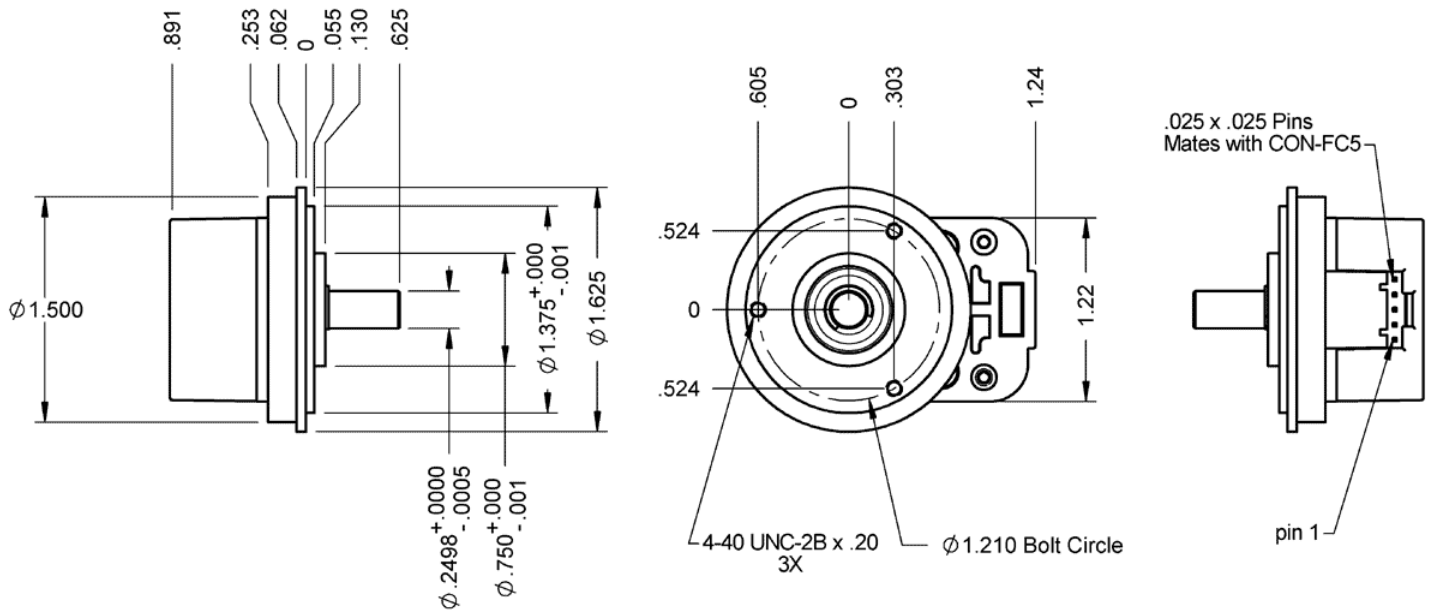

Differential

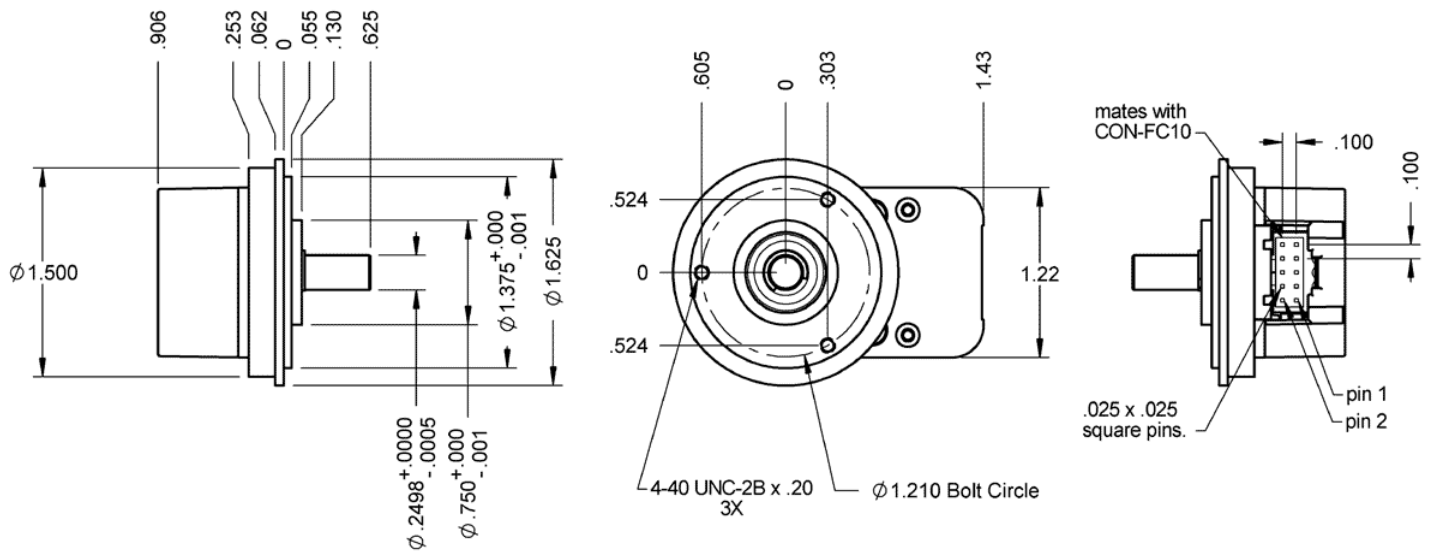

Environmental

Parameter	Value	Units
Operating Temperature	-40 to 100	C

Parameter	Value	Units
Vibration (5Hz to 2kHz)	20	G
Electrostatic Discharge, Human Body Model	± 4	kV

Mechanical

Parameter	Dimension / Units
Max. Shaft Speed	10000 rpm
Max. Acceleration	100000 rad/sec ²
Max. Shaft Torque	0.05 in-oz
Max. Shaft Loading	2 lbs.
Bearing Life	life in millions of revs = $(90/P)^3$ where P = radial load in pounds.
Weight	
Single-ended	2.2 oz.
Differential	2.3 oz.
Max. Shaft Total Indicated Runout	.0006 in.
Moment of Inertia	6.1×10^{-6} oz-in-s ²
Technical Bulletin TB1001 - Shaft and Bore Tolerances	Download

Phase Relationship

B leads A in a clockwise shaft rotation, and A leads B in counterclockwise shaft rotation viewed from the shaft side of the encoder (see the EM1 page).

Single-ended Electrical

- Specifications apply over entire operating temperature range.
- Typical values are specified at Vcc = 5.0Vdc and 25 ° C.
- For complete details, see the EM1 product page.

Parameter	Min.	Typ.	Max.	Units	Conditions
Supply Voltage	4.5	5.0	5.5	V	
Supply Current		27	33	mA	CPR < 500, no load
		50	62	mA	CPR ≥ 500, no load
Low-level Output			0.5	V	IOL = 8mA max.
High-level Output	2.0			V	IOH = -8mA max.
	4.2	4.8		V	no load

Parameter	Min.	Typ.	Max.	Units	Conditions
Output Current Per Channel	-8		8	mA	
Output Rise Time		110		nS	
Output Fall Time		35		nS	

Differential Electrical

- Specifications apply over entire operating temperature range.
- Typical values are specified at Vcc = 5.0Vdc and 25 ° C.
- For complete details, see the EM1 product pages.

Parameter	Min.	Typ.	Max.	Units	Conditions
Supply Voltage	4.5	5.0	5.5	V	
Supply Current		29	36	mA	CPR < 500, no load
		57	65	mA	CPR ≥ 500, no load
Low-level Output		0.2	0.4	V	IOL = 20mA max.
High-level Output	2.4	3.4		V	IOH = -20mA max.
Differential Output Rise/Fall Time			15	nS	

Pin-outs

5-pin Single-ended

10-pin Differential Standard

Pin	Description	Pin	Description
1	Ground	1	Ground
2	Index	2	Ground
3	A channel	3	Index-
4	+5VDC power	4	Index+
5	B channel	5	A- channel
		6	A+ channel
		7	+5VDC power
		8	+5VDC power
		9	B- channel
		10	B+ channel

Accessories

The following parts are not included with the H15 and must be ordered separately if needed.

1. Cleats & Screws Kit

Part #: CLEAT-KIT

Description: Includes 3 servo mounting cleats and 3 screws.

2. Cleat (Individual)

Part #: CLEAT-5889

Description: This servo cleat is used for the mounting of the H15 encoder using a servo type system. Mounting holes should be arrayed at 120 on a 1.90" bolt circle.

3. Screws

Part #: SCREW-440-250-PH

Description: 4-40 x 1/4" stainless steel phillips pan-head screw.

Product Change Notifications

Title	Date	Description	Download
E5 Insert Overmold - PCN 1008	8/23/2011	In an effort to enhance the robustness of our E5 encoder; the four threaded inserts pressed into the base are being replaced with similar threaded nuts that will be insert-molded into the encoder base. This change in process will retain the insert with much greater strength.	Download
E5 Laser Marking - PCN 1009	8/23/2011	The primary purpose for this change is to create a more durable and longer lasting solution compared to the previous stick on label solution. The E5 encoder covers will now have the US Digital logo, part number, lot code, and pin-outs laser marked onto the top surface.	Download
E5 Mold Update - PCN 1007	8/23/2011	The plastic E5 base and covers have been redesigned for improved moldability and aesthetics. Design changes are primarily alteration of surface drafts, additional or increased corner radii and additional coring out of thick regions. This update was carefully done to preserve the size and shape of the encoder. The new parts are dimensionally equivalent and will fit within the envelope of the previous parts. Only the E-option covers and the G-option bases have features with dimensional changes.	Download
EM1 LED Die - PCN 1016	2/7/2013	As part of US Digital's continual assurance of supply strategy, we have qualified additional sources for our LED die used in our EM1 encoder module, which in turn impacts all of the following products: EM1, E2, E3, E5, E6, H1, H15, H3, H5, H6, HB5M, HB6M, HD25, PE, S1, S2, S5, S6, T5 and T6 The device specification will remain the same, i.e. there will be no change to form, fit or function of the product(s) as specified by US Digital. The appropriate quality and reliability testing has been performed on representative products to ensure normal parametric distribution, consistent with US Digital's quality and reliability standards.	Download
EOL H15 - PCN 1028	6/17/2013	This PCN is a formal notification that US Digital is discontinuing the H15.	Download

EM1 Component
Change Notice

N/A

Unless otherwise specified, the US Digital EM1 optical encoder module will be phased in to replace our previous encoder module, HEDS-9000 Series, supplied by Avago Technologies. [View](#)

Ordering Information

H15 - - -

CPR	Index	Output
32 =	NE = <i>No Index</i>	S = <i>Single-ended</i>
50 =	IE = <i>Index</i>	D = <i>Differential</i>
96 =		
100 =		
192 =		
200 =		
250 =		
256 =		
360 =		
400 =		
500 =		
512 =		
540 =		
720 =		
900 =		
1000 =		
1024 =		
1250 =		

Rules

- Index must be equal to NE when CPR is equal to 32

Notes

- Cables and connectors are not included and must be ordered separately.
- US Digital warrants its products against defects in materials and workmanship for two years. See complete warranty for details.

Base Pricing

Quantity	Price
1	\$110.00
5	\$81.50
10	\$70.33

For volume discounts, please contact us at sales@usdigital.com or 800.736.0194.

- Add 17% per unit for **Output** of Differential
- Add 12% per unit for **Index** of IE or **CPR** greater than or equal to 1000.