

Description

The E7P quick assembly optical incremental kit encoder is designed for high volume, low cost, mid-resolution OEM motion control applications. The E7P was designed as a big brother to the E4P encoder and offers higher resolutions, a wider range of shaft diameters, and mounts to additional bolt circles. The E7P uses a 5V supply and offers two TTL quadrature outputs. A single chip reflective encoder module incorporates an LED, monolithic detector and molded lenses. The phased array technology accepts far wider mechanical tolerance and misalignment than traditional aperture type encoders.

Two screws secure the base using one of three bolt circles. The precision machined aluminum reflective codewheel pushes on by hand using a spacing tool to securely grip the shaft while eliminating set screws (patent pending). The cover snaps on to complete the assembly in seconds.

When mounting holes are not available, a centering tool and stick-on version is available. The T-option specifies a base with a transfer adhesive pre-applied. The backing is peeled off and the base is slid down the shaft guided by the centering tool.

The single-ended output version has a 4-pin connector and is designed to drive cables up to six feet long.

The differential output version has a 6-pin connector and is designed for driving longer cable lengths and maximizes noise immunity. The internal 26C31 differential line driver can source and sink 20 mA at TTL levels. The recommended receiver is industry standard 26C32. Maximum noise immunity is achieved when the differential receiver is terminated with a 150 Ω resistor in series with a .0047 μ F capacitor placed across each differential pair. The capacitor simply conserves power. Otherwise power consumption would increase by approximately 20 mA per pair, or 40 mA for 2 pairs.



Features

- ▶ Quick simple assembly
- ▶ A and B quadrature TTL outputs
- ▶ Fits shaft diameters from 0.118" (3mm) to 0.394" (10mm)
- ▶ Frequency response DC to 30 kHz
- ▶ 180 to 720 cycles per rev (CPR)
- ▶ 720 to 2880 quadrature states per rev.
- ▶ Accepts .020" axial shaft play
- ▶ Single-ended or differential output option
- ▶ 5 V supply

E7P Mechanical Drawing - Options

E7P OEM Optical Kit Encoder Options

C-OPTION COVER
(COMPACT COVER FOR LOWER PROFILE
.430" MAX SHAFT LENGTH)

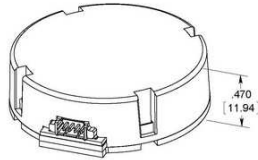

E-OPTION COVER
(EXTENSION FOR SHAFT LENGTHS .588" TO .836")

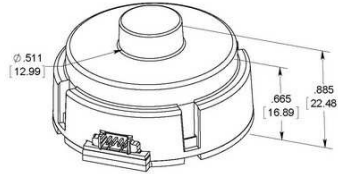

H-OPTION COVER
(COVER HOLE FOR EXTEND SHAFT LENGTHS)

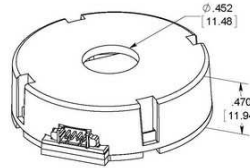

RELEASE DATE: 01/20/11

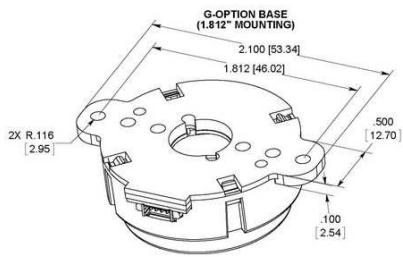

T-OPTION BASE
(ADHESIVE MOUNTING)

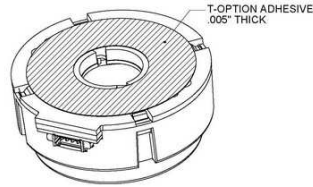

E7P Mechanical Drawing - Default

E7P OEM Optical Kit Encoder

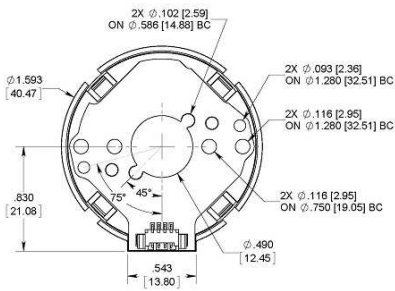

SINGLE-ENDED BASE AND COVER
(DEFAULT OPTIONS SHOWN)

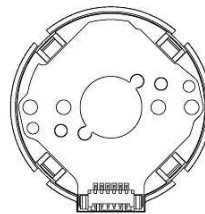
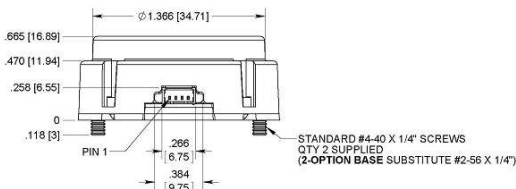

DIFFERENTIAL BASE AND COVER
(DEFAULT OPTIONS SHOWN)

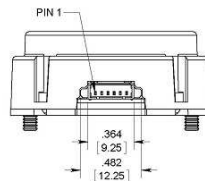

RELEASE DATE: 09/12/11

Environmental

Parameter	Value	Units
Vibration (5Hz to 2kHz)	20	G
Max. Relative Humidity	90	%
Storage Temperature	-40 to 100	C
Operating Temperature	-20 to 100	C
Electrostatic Discharge, Human Body Model		
Single-ended (S -option)	± 3	kV
Differential (D -option)	± 2	

Mechanical

Parameter	Value	Units
Max. Shaft Axial Play	± .020	in.
Max. Off-axis Mounting Tolerance	± .010	in.
Shaft to Mounting Surface Perpendicularity	90 ± 1	deg.
Max. Acceleration	250000	rad/sec ²
Maximum RPM (1) e.x. CPR = 720, max. rpm = 5000 e.x. CPR = 180, max. rpm = 20000	minimum value of (3600000/CPR) and (60000)	rpm
Codewheel Moment of Inertia	7.03 x 10 ⁻⁵	oz-in-s ²
Required Shaft Length		
With D -Cover option	0.355 to 0.587	in.
With C -Cover option	0.355 to 0.430	in.
With E -Cover option	0.355 to 0.836	in.
With H -Cover option	>=0.355	in.
Mounting Screw Torque	2-3	in-lbs

Technical Bulletin TB1001 - Shaft and Bore Tolerances

[Download](#)

(1) 60000 rpm is the maximum rpm due to mechanical considerations. The maximum rpm due to the module's 30kHz maximum count frequency is (3600000/CPR).

Single-ended Electrical

Specifications	Min.	Typ.	Max.	Units	Notes
Supply Voltage	4.5	5.0	5.5	V	
Supply Current		21	27	mA	no load
Low-level Output			0.4	V	IOL = 6 mA

Specifications	Min.	Typ.	Max.	Units	Notes
High-level Output	2.4			V	IOH = -1 mA
Rise Time		500		ns	CL = 25 pF, RL = 2.7 kΩ
Fall Time		100		ns	

Differential Electrical

Specifications	Min.	Typ.	Max.	Units	Notes
Supply Voltage	4.5	5.0	5.5	V	
Supply Current		23	30	mA	
Low-level Output		0.2	0.4	V	IOL = 20mA max.
High-level Output	2.4	3.4		V	IOH = -20mA max.
Differential Output Rise/Fall Time			15	ns	

Phase Relationship

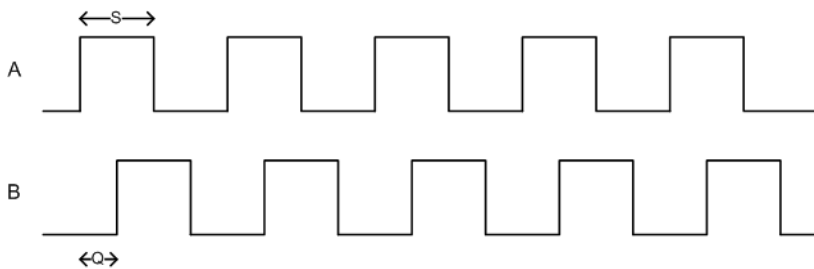

Parameter	Typ.	Max.	Units
Symmetry, S	180 ± 16	180 ± 75	electrical degrees
Quadrature Delay, Q	90 ± 10	90 ± 60	electrical degrees

(1) A leads B for clockwise shaft rotation, and B leads A for counterclockwise rotation viewed from the cover/label side of the encoder.

(2) Typical values represent the encoder performance at typical mounting alignment, whereas the maximum values represent the encoder performance across the range of recommended mounting tolerance.

Pin-outs

4-pin Single-ended (1)		6-pin Differential (2)	
Pin	Description	Pin	Description
1	+5VDC power	1	Ground
2	A channel	2	A channel

4-pin Single-ended (1)

6-pin Differential (2)

3	Ground	3	A- channel
4	B channel	4	+5VDC power
		5	B channel
		6	B- channel

(1) 4-pin single-ended mating connector is CON-MIC4

(2) 6-pin differential mating connector is CON-MIC6

Base Options

The set of screws and hex tool included with each encoder depend on the chosen Base option:

Base Option	Bolt Circle	Screws Included	Hex Tool Included
D	0.750" or 1.280"	low profile #4-40 x 1/4"	.050" hex driver
2	1.280"	standard #2-56 x 1/4"	5/64" hex wrench
G	1.812"	standard #4-40 x 1/4"	3/32" hex wrench
T	n/a	none (.005" thick transfer adhesive with peel away backing mount).	none

Although standard socket head cap screws will work when mounting the **E7P**, to maximize clearance between the codewheel and the top of the screw head, we recommend low profile socket head cap screws when using the holes on the **E7P** board. Both standard or low profile socket head cap screws will work with the **G**-option.

0.750" Bolt Circle / Low Profile #4-40 x 1/4":

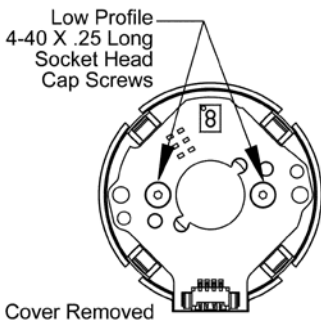

1.280" Bolt Circle / Low Profile #4-40 x 1/4":

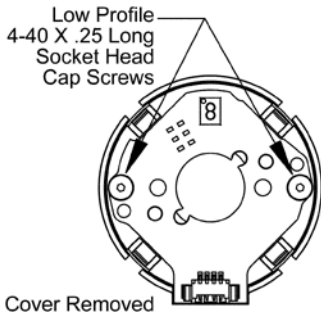

1.280" Bolt Circle / #2-56 x 1/4" (2-option):

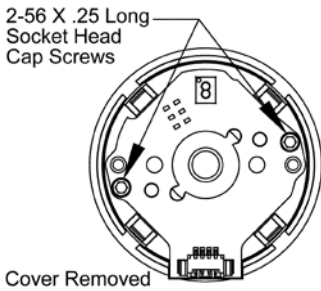

Provides two #2-56 x " screws in place of two #4-40 x 1/4".

1.812" Bolt Circle / #4-40 x 1/4" (G-option):

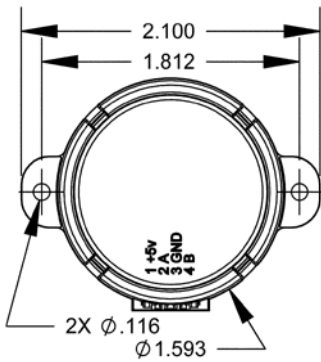

Provides mounting ears on the base allowing for a 1.812" bolt circle.

T-option: Transfer adhesive base



The T-option base provides a transfer adhesive (with peel-off backing) that may be used when mounting holes are not available. A centering tool is required when using this option.

Cover Options

Compact (C-option) provides the lowest profile:

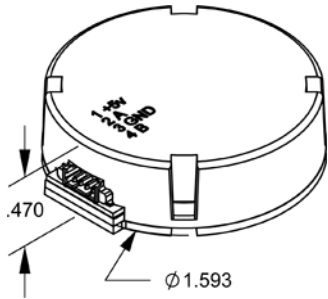

Cover Extension (E-option) provides space in the cover for longer shafts up to 0.836":

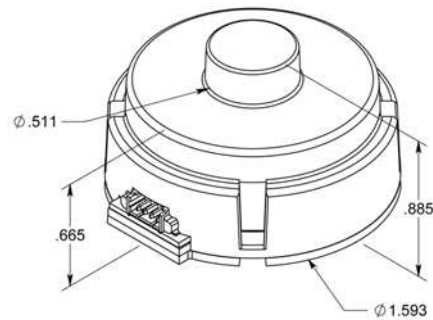

Hole in Cover (H-option) provides a 0.452" diameter hole in the cover for shafts:

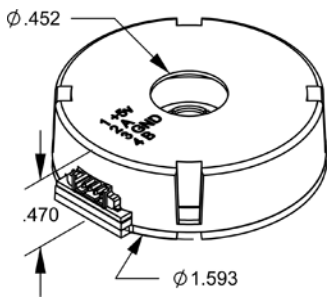

Accessories

1. Centering Tool

The centering tool is only included with the -3 packaging option. It has to be ordered separately for other packaging options.

Part #: CTOOL - (Shaft Diameter)

Description:

This reusable tool provides a simple method for accurately centering the **E7P** base to the shaft. A centering tool is highly recommended when using the **T**-option transfer adhesive.

2. Spacer Tool

A spacer tool is included for all packaging options.

Part #: SPACER-E7P

Description: This reusable tool is used to properly space the codewheel from the encoder.



Assembly Instructions

E7P Assembly Instructions - http://usdigital.com/assets/general/E7P_Assembly_Instructions.pdf

Ordering Information

E7P	CPR	Bore	Output	Cover	Base	Packaging
	180	118 =	S =Single-ended	D =Default	D =Default	B =Encoder components packaged in bulk. One spacer tool per 100 encoders.
	200	3mm		C =Compact Cover	2 =Two #2-56 x 1/4" mounting screws	1 =Each encoder packaged individually. One spacer tool per 100 encoders.
	250	125 = 1/8"	D =Differential	E =Cover Extension	G =Adds mounting "ears" to base to	2 =Each encoder packaged individually. One spacer tool per encoder.
	256 =	156 =		H =Hole in Cover	T =Adds transfer adhesive to base	3 =Each encoder packaged individually. One spacer tool and one centering tool per encoder.
	360	5/32"				
	400	157 =				
	500	4mm				
	512	188 =				
	600	3/16"				
	625	197 =				
	720	5mm				
		236 =				
		6mm				
		250 = 1/4"				
		313 =				
		5/16"				
		315 =				
		8mm				
		375 = 3/8"				
		394 =				
		10mm				

Notes

- Cables and connectors are not included and must be ordered separately.
- US Digital warrants its products against defects in materials and workmanship for two years. See complete warranty for details.

For volume discounts, please contact us at sales@usdigital.com or 800.736.0194.

- Add 20% per unit for **Output** of Differential

- ▶ Add 15% per unit for **Base** of Adds transfer adhesive to base
- ▶ Add \$3.00 per unit for **Packaging** of Each encoder packaged individually. One spacer tool per 100 encoders.
- ▶ Add \$4.00 per unit for **Packaging** of Each encoder packaged individually. One spacer tool per encoder.
- ▶ Add \$7.00 per unit for **Packaging** of Each encoder packaged individually. One spacer tool and one centering tool per encoder.