

Description

The E6 Series rotary encoder has a molded polycarbonate which utilizes either a 5-pin or 10-pin finger-latching connector. This optical incremental encoder is designed to easily mount to and dismount from an existing shaft to provide digital feedback information.

The E6 Series is easy to add to existing applications and only consists of five main components; base, cover, hub/code wheel, optical encoder module and internal differential line driver (differential version only).

The single-ended output version (**S**-option) is typically used with cables of 10 feet or less. For longer cable lengths, the differential output version (**D**-option) is recommended.

The base and cover are both constructed of a rugged 20% glass filled polycarbonate. Attachment of the base to a surface may be accomplished by utilizing one of several machine screw bolt circle options. Positioning of the base to the centerline of a shaft is ensured by use of a centering tool (sold separately). The cover is securely attached to the base with two 4-40 flat head screws to provide a resilient package protecting the internal components.

The internal components consist of a shatterproof mylar disk mounted to a precision machined aluminum hub and an encoder module. The module consists of a highly collimated solid state light source and monolithic phased array sensor, which together provide a system extremely tolerant to mechanical misalignments.

For differential versions: the internal differential line driver (26C31) can source and sink 20mA at TTL levels. The recommended receiver is industry standard 26C32. Maximum noise immunity is achieved when the differential receiver is terminated with a 150 Ω resistor in series with a .0047 μ F capacitor placed across each differential pair. The capacitor simply conserves power; otherwise power consumption would increase by approximately 20mA per pair, or 60mA for 3 pairs.

A secure connection to the E6 Series encoder is made through a 5-pin (single-ended versions) or 10-pin (differential versions) finger-latching connector (sold separately). The mating connectors are available from US Digital with several cable options and lengths.



Features

- ▶ Quick, simple assembly and disassembly
- ▶ Rugged screw-together housing
- ▶ Positive finger-latching connector
- ▶ Accepts .010" axial shaft play
- ▶ Tracks from 0 to 300,000 cycles/sec
- ▶ 64 - 2500 CPR | 256 - 10,000 PPR
- ▶ 2 channel quadrature TTL squarewave outputs
- ▶ Optional index (3rd channel)
- ▶ -40 to +100C operating temperature
- ▶ Fits shaft diameters from 2mm to 1"

Single-Ended

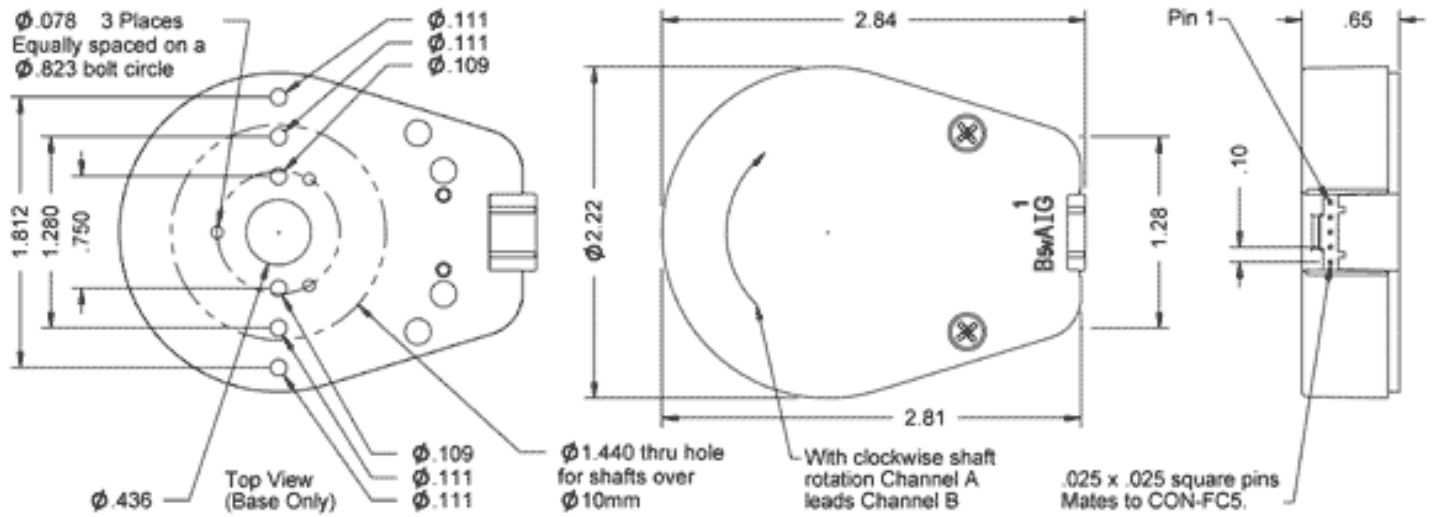

Differential

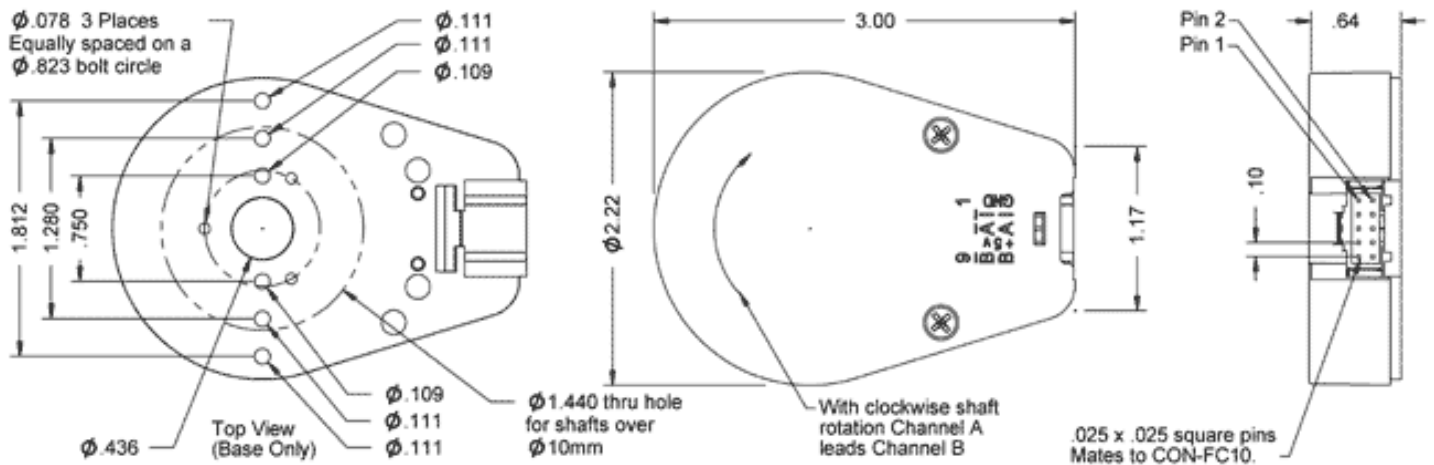

Environmental

Parameter	Value	Units
Operating Temperature	-40 to 100	C
Vibration (5Hz to 2kHz)	20	G
Electrostatic Discharge, Human Body Model	± 4	kV

Mechanical

Parameter	Dimension	Units
Max. Shaft Axial Play	±0.010	in.
Max. Shaft Eccentricity Plus Radial Play (1)	0.004	in.
Max. Acceleration	250000	rad/sec ²
Max. RPM (2) e.x. CPR=2500, max. rpm=7200 e.x. CPR=100, max. rpm=60000	minimum value of ((18 x 10 ⁶) / CPR) and (60000)	rpm
Typical Product Weight		
Single-ended (S -option)	1.55	oz.
Differential (D -option, L -option)	1.83	
Codewheel Moment of Inertia	8.9 x 10 ⁻⁵ for bore < 12mm 4.0 x 10 ⁻⁴ for bore ≥ 12 mm	oz-in-s ²
Hub Set Screw	#3-48 or #4-48	
Hex Wrench Size	0.050	in.
Encoder Base Plate Thickness	0.135	in.
3 Mounting Screw Size	#0-80	
2 Mounting screw size	#2-56 or #4-40	
3 Screw Bolt Circle Diameter (3)	0.823 ± 0.005	in.
2 Screw Bolt Circle Diameter	0.750 ± 0.005	in.
Required Shaft Length (4)	0.445 to 0.570	in.
With E -option (3)	0.445 to 0.750	
With H -option	> 0.445	
Index alignment to hub set screw	180 ± 5	mechanical degrees

(1) Position inaccuracy is proportional to shaft radial play.

(2) 60000 rpm is the maximum rpm due to mechanical considerations. The maximum rpm due to the module's 300kHz maximum count frequency is (18 x 10⁶) / CPR.

(3) Only for shaft diameters < 0.472".

(4) Add 0.125" to all required shaft lengths when using M-option.

Torque Specifications

Parameter	Torque
Hub Set Screw to Shaft	2-3 in-lbs
Cover (4-40 screws through cover into base)	2-4 in-lbs
Base to Mounting Surface	4-6 in-lbs
Base to Mounting Adapter Plate	4-6 in-lbs

Parameter	Torque
Adapter Plate to Mounting Surface	4-6 in-lbs
Module to Base	3.5-4 in-lbs

Phase Relationship

A leads B for clockwise shaft rotation, and B leads A for counterclockwise rotation viewed from the cover/label side of the encoder.

Single-ended Electrical

- Specifications apply over entire operating temperature range.
- Typical values are specified at $V_{cc} = 5.0V_{dc}$ and $25^{\circ}C$.
- For complete details, see the EM1 product page.

Parameter	Min.	Typ.	Max.	Units	Conditions
Supply Voltage	4.5	5.0	5.5	V	
Supply Current		27	33	mA	CPR < 1000, no load
		50	62	mA	CPR \geq 1000, no load
Low-level Output			0.5	V	IOL = 8mA max.
High-level Output	2.0			V	IOH = -8mA max.
	4.2	4.8		V	no load
Output Current Per Channel	-8		8	mA	
Output Rise Time		110		nS	
Output Fall Time		35		nS	

Differential Electrical

- Specifications apply over entire operating temperature range.
- Typical values are specified at $V_{cc} = 5.0V_{dc}$ and $25^{\circ}C$.
- For complete details, see the EM1 product page.

Parameter	Min.	Typ.	Max.	Units	Conditions
Supply Voltage	4.5	5.0	5.5	V	
Supply Current		29	36	mA	CPR < 1000, no load
		57	65	mA	CPR \geq 1000, no load
Low-level Output		0.2	0.4	V	IOL = 20mA max.
High-level Output	2.4	3.4		V	IOH = -20mA max.
Differential Output Rise/Fall Time			15	nS	

 Pin-outs

5-pin Single-ended		10-pin Differential, Standard		10-pin Differential (L-option)		10-pin Single-ended (A-option)	
--------------------	--	-------------------------------	--	--------------------------------	--	--------------------------------	--

Pin	Description	Pin	Description	Pin	Description	Pin	Description
1	Ground	1	Ground	1	No connection	1	A channel
2	Index	2	Ground	2	+5VDC power	2	+5VDC power
3	A channel	3	Index-	3	Ground	3	Ground
4	+5VDC power	4	Index+	4	No connection	4	No connection
5	B channel	5	A- channel	5	A- channel	5	No connection
		6	A+ channel	6	A+ channel	6	Ground
		7	+5VDC power	7	B- channel	7	+5VDC power
		8	+5VDC power	8	B+ channel	8	B+ channel
		9	B- channel	9	Index-	9	+5VDC power
		10	B+ channel	10	Index+	10	Index

 Options

Index

Provides a single pulse per revolution.

3-option

3-option makes all five of these hole diameters .125".

View option:

- Single-ended Version



- Differential Version



E-option

The E-option provides a cylindrical extension to the cover allowing for longer shafts of up to .750".

Please note: Only available for shaft diameters <.472".