

## Description

The E2 optical encoder is designed as a direct replacement for the Avago HEDS / HEDM 5500 - 5600 series.

The E2 is a rotary encoder with a molded polycarbonate enclosure, which utilizes either a 5-pin locking or standard connector. This optical incremental encoder is designed to easily mount to and dismount from an existing motor shaft to provide digital feedback information.

The E2 is easy to add to existing applications and only consists of four main components; base, cover, hub/code wheel and optical encoder module.

The E2 is normally designed for applications of 10 feet or less. For longer cable lengths, adding a PC4 / PC5 differential line driver is recommended.

The base and cover are both constructed of rugged 20% glass filled polycarbonate. Attachment of the base to a surface may be accomplished by utilizing one of several machine screw bolt circle options. Positioning of the base to the centerline of a shaft is ensured by use of a centering tool (sold separately). The cover is securely attached to the base with two 4-40 flat head screws to provide a resilient package protecting the internal components.

The internal components consist of a shatterproof mylar disk mounted to a precision machined aluminum hub and an encoder module. The module consists of a highly collimated solid state light source and monolithic phased array sensor, which together provide a system extremely tolerant to mechanical misalignments.

Connection to the E2 product is made through either a 5-pin locking or standard connector (sold separately). The mating connectors are available from US Digital with several cable options and lengths.

### Avago Direct Replacements:

US Digital's E2 encoder may now be used as direct replacements for Avago HEDM-5500, HEDM-5600, HEDS-5500, HEDS-5600.

## Mechanical Drawing



## Features

- ▶ Quick, simple assembly and disassembly
- ▶ Rugged screw-together housing
- ▶ Accepts .010" axial shaft play
- ▶ Tracks from 0 to 300000 cycles/sec
- ▶ 32 to 1250 cycles per revolution (CPR)
- ▶ 128 to 5000 pulses per revolution (PPR)
- ▶ 2 channel quadrature TTL squarewave outputs
- ▶ Optional index (3rd channel)
- ▶ -40 to +100C operating temperature
- ▶ Mounting compatibility with HEDS-5500

E2 Optical Kit Encoder Drawing

RELEASE DATE 7/2012

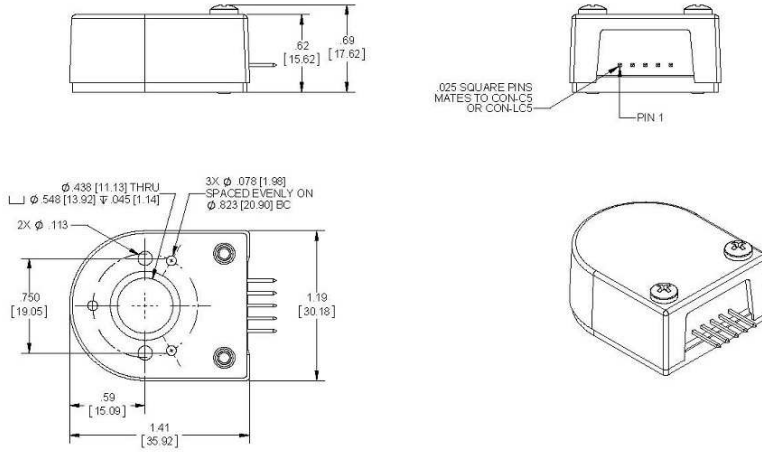

US DIGITAL 1400 NE 136th Avenue  
Vancouver, Washington 98684, USA  
info@usdigital.com  
www.usdigital.com  
Local: 360.260.2468  
Toll-Free: 800.736.0194

UNITS: INCHES (MM)  
METRIC DIMENSIONS FOR REFERENCE ONLY

## Environmental

Parameter	Value	Units
Operating Temperature	-40 to 100	C
Vibration (5Hz to 2kHz)	20	G
Electrostatic Discharge, Human Body Model	± 4	kV

## Mechanical

Parameter	Value	Units
Max. Shaft Axial Play	±0.010	in.
Max. Shaft Eccentricity Plus Radial Play (1)	0.004	in.
Max. Acceleration	250000	rad/sec <sup>2</sup>
Max. RPM (2) e.x. CPR=1250, max. rpm=14400 e.x. CPR=100, max. rpm=60000	minimum value of ((18 x 10 <sup>6</sup> ) / CPR) and (60000) rpm	
Typical Product Weight	0.56	oz.
Codewheel Moment of Inertia	8.0 x 10 <sup>-6</sup>	oz-in-s <sup>2</sup>
Hub Set Screw	#4-48	
Hex Wrench Size	0.050	in.

Parameter	Value	Units
Encoder Base plate Thickness	0.135	in.
3 Mounting Screw Size	#0-80	
2 Mounting Screw Size	#2-56 or #4-40	
3 Screw Bolt Circle Diameter	0.823 ± 0.005	in.
2 Screw Bolt Circle Diameter	0.750 ± 0.005	in.
Required Shaft Length (3)	0.445 to 0.570	in.
With <b>E</b> -option	0.445 to 0.795	in.
With <b>H</b> -option	> 0.445	in.
Index alignment to hub set screw	180 ± 5	mechanical degrees
<a href="#">Technical Bulletin TB1001 - Shaft and Bore Tolerances</a>		<a href="#">Download</a>

(1) Position inaccuracy is proportional to shaft radial play.

(2) 60000 rpm is the maximum rpm due to mechanical considerations. The maximum rpm due to the module's 300kHz maximum count frequency is  $(18 \times 10^6) / \text{CPR}$ .

(3) Add 0.125" to the required shaft length when using **R**-option.

## Torque Specifications

Parameter	Torque
Hub Set Screw to Shaft	2-3 in-lbs
Cover (4-40 screws through cover into base)	2-4 in-lbs
Base to Mounting Surface	4-6 in-lbs
Base to Mounting Adapter Plate	4-6 in-lbs
Adapter Plate to Mounting Surface (4-40 screws)	4-6 in-lbs
Module to Base	3.5-4 in-lbs

## Phase Relationship

B leads A for clockwise shaft rotation, and A leads B for counterclockwise rotation viewed from the cover/label side of the encoder.

## Electrical

- Specifications apply over entire operating temperature range.
- Typical values are specified at  $V_{cc} = 5.0\text{Vdc}$  and  $25^\circ\text{C}$ .
- For complete details, see the EM1 product page.

Parameter	Min.	Typ.	Max.	Units	Conditions
Supply Voltage	4.5	5.0	5.5	V	
Supply Current		27	33	mA	CPR < 500, no load
		50	62	mA	CPR ≥ 500, no load
Low-level Output			0.5	V	IOL = 8mA max.
High-level Output	2.0			V	IOH = -8mA max.
	4.2	4.8		V	no load
Output Current Per Channel	-8		8	mA	
Output Rise Time		110		nS	
Output Fall Time		35		nS	

## Pin-Out

Pin	Description
1	Ground
2	Index
3	A channel
4	+5VDC power
5	B channel

**Note:** 5-pin single ended mating connector is CON-C5 or CON-LC5

## Options

### Index

Provides a single pulse per revolution.



### 3-option

3-option makes all five of these hole diameters .125". If desired, the two .096" diameter recesses will mate with matching aligning pins. The .438" diameter center hole can also mate with a motor boss.



### A-option

A-option adds a .497" diameter alignment shoulder designed to slip into a .500" diameter recess in the mounting surface centered around the shaft.



**E-option**

The **E**-option provides a cylindrical extension to the cover allowing for longer shafts of up to .795".



**G-option**

This option includes molded ears on the base which enable it to be mounted to a 1.812" diameter bolt circle. The mounting holes are designed to fit 4-40 screws. Because the ears are molded to the base this does not increase the thickness of the encoder and does not add to the required shaft length. This option will work with shaft lengths of .445" to .570".



**H-option**

The **H**-option adds a hole to the cover for the shaft to pass through.

Shafts <.375", a .375" diameter hole is supplied.

Shafts >=.375", a .500" diameter hole is supplied.



**R-option**

This adapter is an 1/8" thick fiberglass adapter which is pre-mounted to the base of the encoder. It allows the **E2** to be rotated 15 ° while operating for index orientation. Use three 4-40 x 1/4" screws (sold separately). When installing the hub, rotate the index to the approximate position. After assembly, with the 3 screws loose, rotate while operating to the desired index location and tighten. Note that this adds 1/8" to the required shaft length.



**T-option**

When mounting holes are not available, a pre-applied transfer adhesive (with peel-off backing) is available for "stick-on" mounting. Use the centering tool (sold separately) to slide the base into position. **T**-option specifies transfer adhesive on the standard mounting base. A centering tool is highly recommended when using transfer adhesive.

**Instructions:** To use transfer adhesive, peel off paper backing and slip tool into center hole of base and slide both down shaft as one piece. Press to form a good bond, then slip tool off and continue with standard mounting instructions.

## Accessories

### 1. Centering Tool

The centering tool is only included with the **-3** packaging option. It has to be ordered separately for other packaging options.

**Part #: CTOOL - (Shaft Diameter)**

**Description:** This reusable tool provides a simple method for accurately centering the **E2** base onto the shaft, promoting hub to base concentricity and thus accuracy. It is recommended for the following situations:

- › When using mounting screws smaller than #4-40.
- › When the position of the mounting holes is in question.
- › When using the 3-hole mounting pattern.
- › When using the **T**-option transfer adhesive.

**Instructions:** When mounting encoder base, slide centering tool down shaft until it slips into centering hole of encoder base. Tighten mounting screws, then remove centering tool.

**2. Hex Tool**

Depending on the order packaging option, either a hex driver or hex wrench is included.

**Part #: HEXD-050** (only included with **-B** or **-1** packaging options)

**Description:** Hex driver, 0.050" flat-to-flat for #3-48 or #4-48 set screws.

**Part #: HEXW-050** (only included with **-2** or **-3** packaging options)

**Description:** Hex wrench, 0.050" flat-to-flat for #3-48 or #4-48 set screws.

**3. Spacer Tool**

A spacer tool is included for all packaging options.

**Part #: SPACER-96**

**Description:** For shafts  $\leq 0.315$ "

**Part #: SPACER-4192**

**Description:** For shaft sizes 0.375" or 10mm

**4. Screws**

Screws for base mounting must be purchased separately. Screws for mounting the housing to the base are included.

**Part #: SCREW-080-250-PH**

**Description:** Pan Head, Cross Drive #0-80 UNF x 1/4"

**Quantity Required for Mounting:** 3 per encoder

**Part #: SCREW-256-250-PH**

**Description:** Pan Head, Cross Drive #2-56 UNC x 1/4"

**Quantity Required for Mounting:** 2 per encoder

**Part #: SCREW-440-250-PH**

**Description:** Pan Head, Cross Drive #4-40 UNC x 1/4"

**Quantity Required for Mounting:** 2 per encoder

 **Assembly Instructions**

Link to E2 Assembly Instructions:

<http://www.usdigital.com/support/assembly/e2-assembly>

## Output Waveforms

SINGLE-ENDED

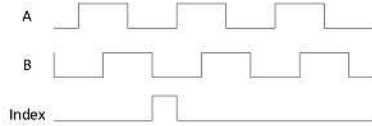

## Product Change Notifications

Title	Date	Description	Download
		As part of US Digital's continual assurance of supply strategy, we have qualified additional sources for our LED die used in our EM1 encoder module, which in turn impacts all of the following products:	Download
EM1 LED Die - PCN 1016	2/7/2013	EM1, E2, E3, E5, E6, H1, H15, H3, H5, H6, HB5M, HB6M, HD25, PE, S1, S2, S5, S6, T5 and T6  The device specification will remain the same, i.e. there will be no change to form, fit or function of the product(s) as specified by US Digital. The appropriate quality and reliability testing has been performed on representative products to ensure normal parametric distribution, consistent with US Digital's quality and reliability standards.	
EM1 Component Change Notice	N/A	Unless otherwise specified, the US Digital EM1 optical encoder module will be phased in to replace our previous encoder module, HEDS-9000 Series, supplied by Avago Technologies.	View

## Ordering Information

E2	CPR	Bore	Index	Cover	Base	Packaging
	32	079 =	NE =No	D =Default	D =Default	B =Encoder components packaged in bulk. One spacer tool and one hex wrench for orders up to 9 units, for orders of 10 units and above one spacer tool and one hex driver per 100 encoders.
	50	2mm	Index	E =Cover	3 =Base	1 =Encoders Individually packaged. One spacer tool and one hex wrench for orders up to 9 units, for orders of 10 units and above one spacer tool and one hex driver per 100 encoders.
	96	118 =	IE =	Extension	Mounting Holes	2 =Encoders packaged individually with one spacer tool and one hex wrench per encoder.
	100	3mm	Index	H =Hole in	become .125"	3 =Encoders packaged individually with one spacer tool, one hex wrench, and one centering tool per encoder.
	192	125 =		Cover	A =Adds self-aligning	
	200	1/8"			shoulder to base	
	250	156 =			G =Adds 1.812	
	256	5/32"			mounting "ears"	
	360	157 =			to base	
	400 =	4mm			R =Adds 3-slot	
	500 =	188 =			adapter to	
	512 =	3/16"			bottom of base	
	540 =	197 =			T =Transfer	
	720 =	5mm			Adhesive	
	900 =	236 =				
	1000 =	6mm				
	1024 =	250 =				
	1250 =	1/4"				
		276 =				
		7mm				
		313 =				
		5/16"				
		315 =				
		8mm				
		375 =				
		3/8"				
		394 =				
		10mm				

### Rules

- ▶ Index must be equal to NE when CPR is equal to 32
- ▶ Cover must be something other than E when Bore is greater than 394

### Notes

- ▶ US Digital warrants its products against defects in materials and workmanship for two years. See complete warranty for details.

## Base Pricing

Quantity	Price
1	\$74.90
5	\$51.50
10	\$43.09

For volume discounts, please contact us at [sales@usdigital.com](mailto:sales@usdigital.com) or 800.736.0194.

- Add \$7.00 per unit for **Base** of Adds 3-slot adapter to bottom of base
- Add \$6.00 per unit for **Base** of Transfer Adhesive
- Add \$3.00 per unit for **Packaging** of Encoders Individually packaged. One spacer tool and one hex wrench for orders up to 9 units, for orders of 10 units and above one spacer tool and one hex driver per 100 encoders.
- Add \$4.00 per unit for **Packaging** of Encoders packaged individually with one spacer tool and one hex wrench per encoder.
- Add \$7.00 per unit for **Packaging** of Encoders packaged individually with one spacer tool, one hex wrench, and one centering tool per encoder.
- Add 21% per unit for **Index** of IE or **CPR** greater than or equal to 1000.