

FCR resistors use thick film technology on an alumina substrate. The design yields greater power densities, requiring substantially less board space than other radial packages

Characteristics

Resistor range 2R - 100K
Temperature coefficient: ± 100 ppm/ °C
Tolerance: G ($\pm 2\%$), J ($\pm 5\%$), K ($\pm 10\%$)
Power dissipation: 10W at 70°C
Rated voltage: 300 Vac
Operational temperature range : -40 to + 125 °C

Dimensions (mm)

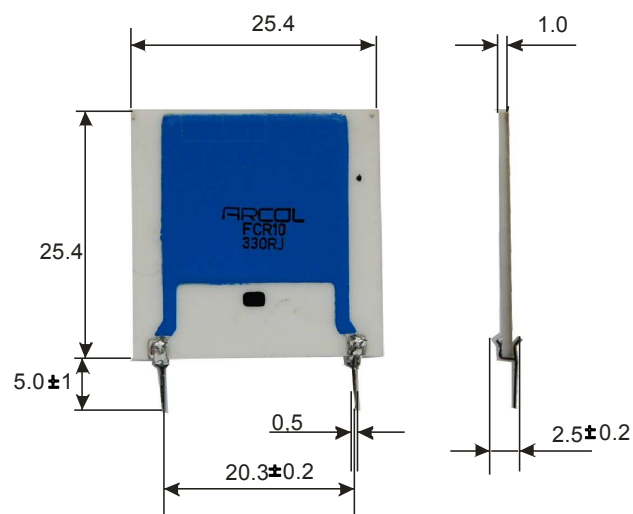

ARCOL UK Limited,
Threemilestone Ind. Estate
Truro, Cornwall, TR4 9LG
T +44 (0)1872 277431
F +44 (0)1872 222002
E sales@arcolresistors.com

www.arcolresistors.com

The information contained herein does not form part of a contract and is subject to change without notice. Arcol operate a policy of continual product development, therefore, specifications may change.

It is the responsibility of the customer to ensure that the component selected from our range is suitable for the intended application. If in doubt please ask Arcol.

FCR resistors use thick film technology on an alumina substrate. The design yields greater power densities, requiring substantially less board space than other radial packages

Characteristics

Resistor range 1R - 100K
Temperature coefficient: ± 100 ppm/ $^{\circ}\text{C}$
Tolerance: G ($\pm 2\%$), J ($\pm 5\%$), K ($\pm 10\%$)
Power dissipation: 5W at 70 $^{\circ}\text{C}$
Rated voltage: 300 Vac
Operational temperature range : -40 to + 125 $^{\circ}\text{C}$

Dimensions (mm)

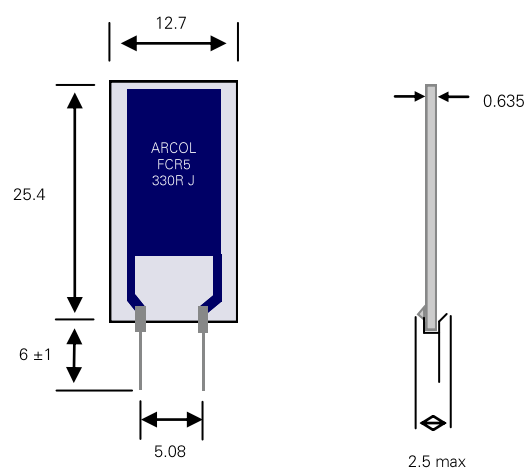

ARCOL UK Limited,
Threemilestone Ind. Estate
Truro, Cornwall, TR4 9LG
T +44 (0)1872 277431
F +44 (0)1872 222002
E sales@arcolresistors.com

www.arcolresistors.com

The information contained herein does not form part of a contract and is subject to change without notice. Arcol operate a policy of continual product development, therefore, specifications may change.

It is the responsibility of the customer to ensure that the component selected from our range is suitable for the intended application. If in doubt please ask Arcol.