

ACPP Precision Surface Mount Passivated Resistors



- Precision metal film technology
- Extended ohmic range 1R – 2M
- Precision to $\pm 0.01\%$ and 5ppm/ $^{\circ}\text{C}$
- TCR grades 50, 25, 15, 10, 5ppm/ $^{\circ}\text{C}$
- Passivated range for superior humidity performance
- RoHS Compliant
- Load life stability and humidity to 0.05%



Dimensions (mm)

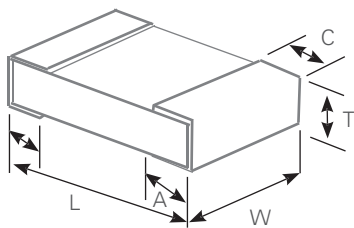

	L	W	T max	A	C
0201	0.6 ± 0.05	0.3 ± 0.05	0.26	0.12 ± 0.05	0.12 ± 0.05
0402	1.0 ± 0.05	0.5 ± 0.05	0.40	0.2 ± 0.1	0.2 ± 0.1
0603	1.6 ± 0.2	0.8 ± 0.2	0.55	0.3 ± 0.2	0.3 ± 0.2
0805	2.0 ± 0.2	1.25 ± 0.2	0.65	0.4 ± 0.2	0.4 ± 0.2
1206	3.2 ± 0.2	1.6 ± 0.2	0.65	0.5 ± 0.2	0.5 ± 0.2
1210	3.2 ± 0.2	2.6 ± 0.2	0.50	0.45 ± 0.2	0.5 ± 0.2
2010	4.9 ± 0.2	2.4 ± 0.2	0.65	0.5 ± 0.2	0.6 ± 0.2
2512	6.3 ± 0.2	3.1 ± 0.2	0.65	0.5 ± 0.2	0.6 ± 0.2

Construction

A thin-film material is selectively deposited on a 96% alumina substrate together with metallic contacts at each end of the resistor. The unadjusted resistors are heat treated to give the required TCR and stability, then a precisely controlled laser trim process adjusts the resistance value. Epoxy protection is applied and wrap-around terminations are added and plated with Nickel then Tin. Each resistor is measured immediately before packing into tape.

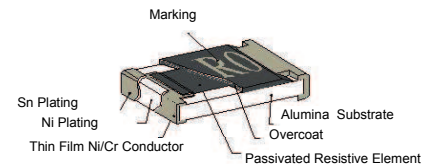

Ordering Procedure

Standard Resistor: Series, Size, Value, TCR Code,

Tolerance Code

e.g: ACPP 1206 25R D F

TCR Code available at www.arcolresistors.com

Termination

The chips are supplied with 100% Sn matte plated wrap-around terminations suitable for soldering.

Solderability

The terminations have an electroplated nickel barrier and tin coating. This ensures excellent 'leach' resistance properties and solderability.

ARCOL UK Limited,
Threemilestone Ind. Estate,
Truro, Cornwall TR4 9LG, UK.
T +44 (0) 1872 277431
F +44 (0) 1872 222002
E sales@arcolresistors.com

www.arcolresistors.com

The information contained herein does not form part of a contract and is subject to change without notice. Arcol operate a policy of continual product development therefore, specifications may change.

It is the responsibility of the customer to ensure that the component selected from our range is suitable for the intended application. If in doubt please ask Arcol.

Electrical Specifications

Type	TCR (ppm/°C)	Power (W)	Limiting Element Voltage (V)	Standard Ohmic Value Range E24 or E96		
				0.5%	0.25%	0.1%
ACPP0402	50	0.063	25	25R-25K	25R-25K	25R-25K
	25			25R-25K	25R-25K	25R-25K
ACPP0603	50	0.063	50	25R-200K	25R-200K	25R-200K
	25			25R-200K	25R-200K	25R-200K
ACPP0805	50	0.1	100	25R-400K	25R-400K	25R-400K
	25			25R-400K	25R-400K	25R-400K
ACPP1206	50	0.125	150	25R-500K	25R-500K	25R-500K
	25			25R-500K	25R-500K	25R-500K
ACPP2010	50	0.25	150	25R-600K	25R-600K	25R-600K
	25			25R-600K	25R-600K	25R-600K
ACPP2512	50	0.5	150	25R-600K	25R-600K	25R-600K
	25			25R-600K	25R-600K	25R-600K

Characteristics

Test Parameters	Conditions	Maximum change (+R05)	
		0603 to 2512	0402
Load life	1000 hours rated load @ 70°C	0.05%	0.25%
Humidity	1000hrs @ 40°C, 90 – 95%RH.	0.05%	0.5%
Short term overload	6.25 x rated Power, or 2 x LEV, for 5 sec	0.02%	0.1%
High temperature operation	1000 hours at 125°C	0.05%	0.5%
Temperature	5 cycles -55°C, 125°C	0.02%	0.1%
Resistance to solder heat	270°C, 10sec	0.02%	0.1%
Solderability	235°C, 2 sec	95% minimum coverage	

Application Notes

ACPP resistors are ideally suited for handling by automatic methods due to their rectangular shape and the small dimensional tolerances. Electrical connection to a ceramic substrate or to a printed circuit board can be made by reflow or wave soldering of wrap-around terminations.

Wrap-around terminations provide good leach properties and ensure reliable contact. Due to the robust construction, the ACPP can be immersed in the solder bath for 30 seconds at 260°C. This enables the resistor to be mounted on one side of a printed circuit board and wire-leaded components applied on the other side.

ACPP resistors themselves can operate at a maximum temperature of 125°C (see performance above) (155°C for High Power grades). For soldered resistors, the joint temperature should not exceed 110°C. This condition is met when the stated power levels at 70°C are used.

ARCOL UK Limited,
Threemilestone Ind. Estate,
Truro, Cornwall TR4 9LG, UK.
T +44 (0) 1872 277431
F +44 (0) 1872 222002
E sales@arcolresistors.com

www.arcolresistors.com

The information contained herein does not form part of a contract and is subject to change without notice. Arcol operate a policy of continual product development therefore, specifications may change.

It is the responsibility of the customer to ensure that the component selected from our range is suitable for the intended application. If in doubt please ask Arcol.

ACPP Precision Surface Mount Passivated Resistors



Reel Dimensions (mm) and Quantity

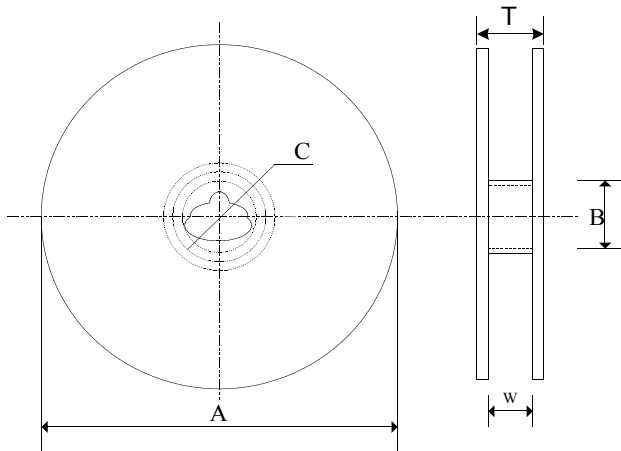

Codes	$\varnothing A$	$\varnothing B$	$\varnothing C$	W	T	Paper Tape	Emboss Plastic Tape
ACPP0201	178.0 \pm 1.0	60.0 \pm 1.0	13.5 \pm 0.7	9.5 \pm 1.0	11.5 \pm 1.0	10,000	-
ACPP0402	178.0 \pm 1.0	60.0 \pm 1.0	13.5 \pm 0.7	9.5 \pm 1.0	11.5 \pm 1.0	10,000	-
ACPP0603	178.0 \pm 1.0	60.0 \pm 1.0	13.5 \pm 0.7	9.5 \pm 1.0	11.5 \pm 1.0	5,000	-
ACPP0805	178.0 \pm 1.0	60.0 \pm 1.0	13.5 \pm 0.7	9.5 \pm 1.0	11.5 \pm 1.0	5,000	-
ACPP1206	178.0 \pm 1.0	60.0 \pm 1.0	13.5 \pm 0.7	9.5 \pm 1.0	11.5 \pm 1.0	5,000	-
ACPP1210	178.0 \pm 1.0	60.0 \pm 1.0	13.5 \pm 0.7	13.5 \pm 1.0	15.5 \pm 1.0	-	4,000
ACPP2010	178.0 \pm 1.0	60.0 \pm 1.0	13.5 \pm 0.7	13.5 \pm 1.0	15.5 \pm 1.0	-	4,000
ACPP2512	178.0 \pm 1.0	60.0 \pm 1.0	13.5 \pm 0.7	9.5 \pm 1.0	11.5 \pm 1.0	5,000	-

Paper Tape Dimensions (mm)

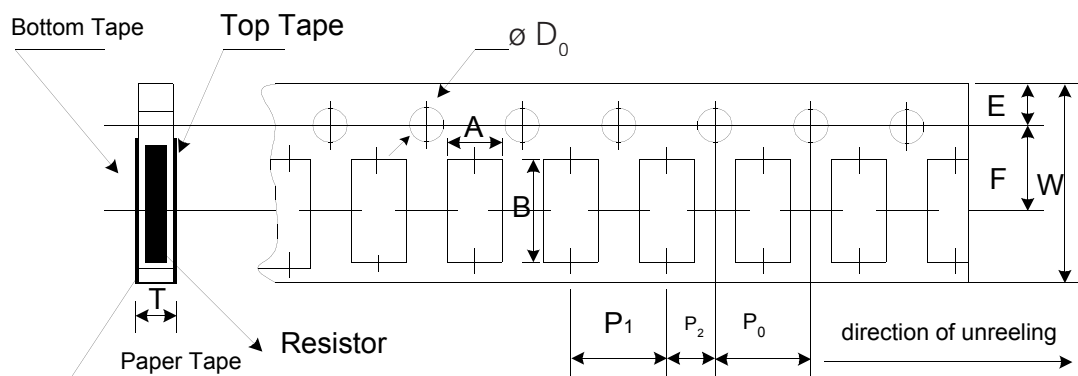

Codes	A	B	W	E	F	P0	P1	P2	$\varnothing D_0$	T
ACPP0201	0.40 \pm 0.05	0.70 \pm 0.05	8.00 \pm 0.10	1.75 \pm 0.05	3.50 \pm 0.05	4.00 \pm 0.10	2.00 \pm 0.05	2.00 \pm 0.05	1.55 \pm 0.05	0.265 \pm 0.05
ACPP0402	0.70 \pm 0.05	1.16 \pm 0.05	8.00 \pm 0.10	1.75 \pm 0.05	3.5 \pm 0.05	4.00 \pm 0.10	2.00 \pm 0.05	2.00 \pm 0.05	1.55 \pm 0.05	0.40 \pm 0.03
ACPP0603	1.10 \pm 0.05	1.90 \pm 0.05	8.00 \pm 0.10	1.75 \pm 0.05	3.5 \pm 0.05	4.00 \pm 0.10	4.00 \pm 0.10	2.00 \pm 0.05	1.55 \pm 0.05	0.60 \pm 0.03
ACPP0805	1.60 \pm 0.05	2.37 \pm 0.05	8.00 \pm 0.10	1.75 \pm 0.05	3.5 \pm 0.05	4.00 \pm 0.10	4.00 \pm 0.10	2.00 \pm 0.05	1.55 \pm 0.05	0.75 \pm 0.05
ACPP1206	2.00 \pm 0.05	3.55 \pm 0.05	8.00 \pm 0.10	1.75 \pm 0.05	3.5 \pm 0.05	4.00 \pm 0.10	4.00 \pm 0.10	2.00 \pm 0.05	1.55 \pm 0.05	0.75 \pm 0.05

Emboss Plastic Tape Dimensions (mm)

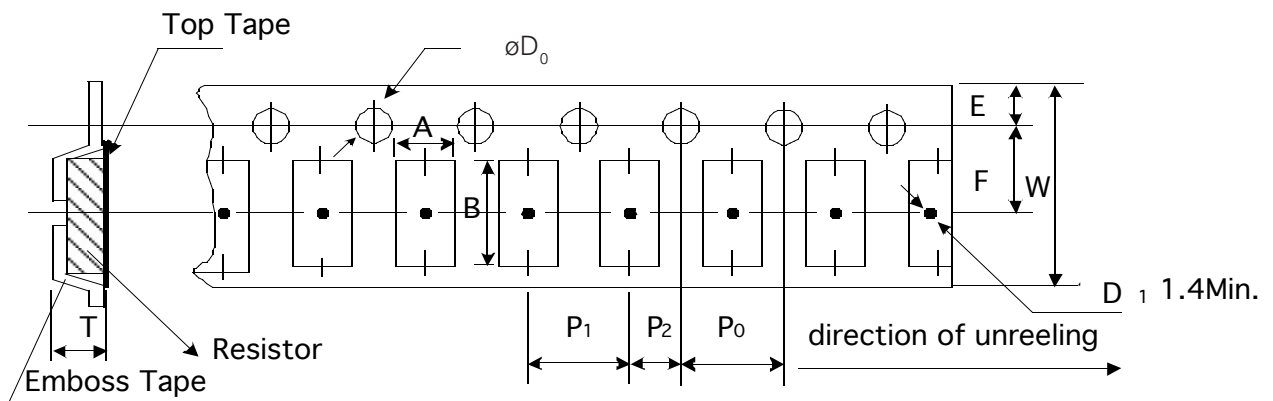

Codes	A	B	W	E	F	P0	P1	P2	øD ₀	T
ACPP0201	0.40±0.05	0.70±0.05	8.00±0.10	1.75±0.05	3.50±0.05	4.00±0.10	2.00±0.05	2.00±0.05	1.55±0.05	0.265±0.05
ACPP0402	0.70±0.05	1.16±0.05	8.00±0.10	1.75±0.05	3.5±0.05	4.00±0.10	2.00±0.05	2.00±0.05	1.55±0.05	0.40±0.03
ACPP0603	1.10±0.05	1.90±0.05	8.00±0.10	1.75±0.05	3.5±0.05	4.00±0.10	4.00±0.10	2.00±0.05	1.55±0.05	0.60±0.03
ACPP0805	1.60±0.05	2.37±0.05	8.00±0.10	1.75±0.05	3.5±0.05	4.00±0.10	4.00±0.10	2.00±0.05	1.55±0.05	0.75±0.05
ACPP1206	2.00±0.05	3.55±0.05	8.00±0.10	1.75±0.05	3.5±0.05	4.00±0.10	4.00±0.10	2.00±0.05	1.55±0.05	0.75±0.05