

# Silicon-Based Technology Corp.

*Small-Signal Schottky Barrier Diodes*

**SBT70D Series**

SBT70D series are Schottky Barrier Diodes fabricated by a series of proprietary Schottky barrier patents and technologies (SBT<sup>®</sup>) developed by Silicon-Based Technology Corporation, which exhibit high-performance characteristics for modern switching, conversion and protection applications with high speed and low power consumptions. The package types as described in this data sheet are set forth in routine production; other packages are available upon special orders.

## ■ Features and Advantages:

- Low forward voltage drop ( $V_F$ )
- Low reverse leakage current ( $I_R$ )
- Very small conduction power loss
- Very small switching power loss
- Very high switching speed
- Very high reliability

## ■ Electrical Characteristics : (@ $T_A=25^{\circ}\text{C}$ unless otherwise specified)

Characteristic	Symbol	Min.	Max.	Unit	Test Conditions
Reverse Breakdown Voltage (Note 2)	$V_{(BR)R}$	70	-	V	$I_R=10\mu\text{A}$
Forward Voltage (Note 2)	$V_F$	-	350	mV	$I_F=1.0\text{mA}$ , $t_p<300\mu\text{S}$
			600	mV	$I_F=15\text{mA}$ , $t_p<300\mu\text{S}$
Leakage Current (Note 2)	$I_R$	-	100	nA	$V_R=30\text{V}$
Total Capacitance	$C_T$	-	2.0	pF	$V_R=0$ , $f=1.0\text{MHz}$



**Silicon-Based Technology Corporation**

1F, No. 23, R&D Rd. I, Hsinchu Science Park, Taiwan, R.O.C

Tel : 886-3-5777897

Fax : 886-3-5779832

**■ Maximum Ratings : (@T<sub>A</sub>=25°C unless otherwise specified)**

<b>Characteristic</b>	<b>Symbol</b>	<b>Value</b>	<b>Unit</b>
Peak Repetitive Reverse Voltage	V <sub>RRM</sub>		
Working Peak Reverse Voltage	V <sub>RWM</sub>	70	V
DC Blocking Voltage	V <sub>R</sub>		
RMS Reverse Voltage	V <sub>R(RMS)</sub>	49	V
Forward Continuous Current (Note 1)	I <sub>FM</sub>	70	mA
Non-Repetitive Peak Forward Surge Current @t=1.0s	I <sub>FSM</sub>	100	mA
Power Dissipation (Note 1)	P <sub>d</sub>	200	mW
Thermal Resistance Junction to Ambient (Note 1)	R <sub>θJA</sub>	625	°C/W
Operating Temperature Range	T <sub>j</sub>	-55 to +125	°C
Storage Temperature Range	T <sub>STG</sub>	-65 to +150	°C

- Notes: 1. Device is mounted on FR-4 PC board with a recommended pad layout, which can be found on our website at [www.sbt.com.tw](http://www.sbt.com.tw)
2. Short duration test pulse is used to minimize self-heating effect.

**■ Package Data :**

- Case: Molded Plastic Material (UL Flammability Classification 94V-0)
- Terminals: Solderable Plated Terminals (MIL-STD-202, Method 208)
- Lead Free Plating (Matte Tin Finish)
- Polarity: See device configurations below
- Approx. Weight: 0.006 grams
- Package outline and dimensions (see below)

### SOT-363

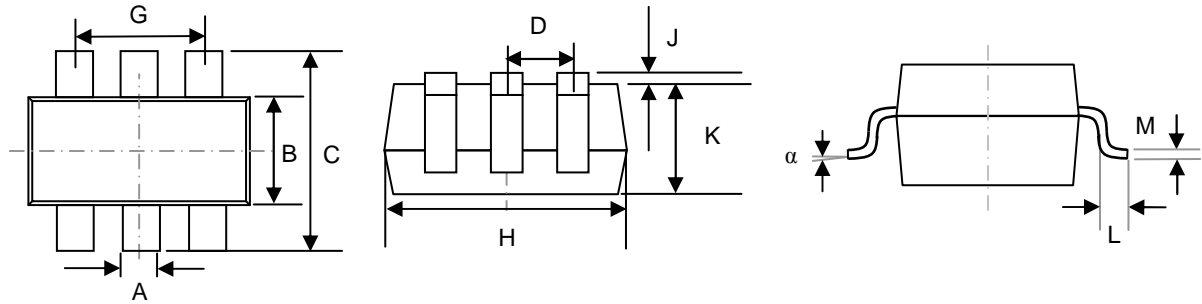

#### DIMENSIONS (MM)

	A	B	C	D	F	H	J	K	L	M	$\alpha$
Min.	0.10	1.15	2.00	0.65	0.30	1.80	-	0.90	0.25	0.10	0°
Max.	0.30	1.35	2.20	Nominal	0.40	2.20	0.10	1.00	0.40	0.25	8°

#### ■ Device Configurations :

### TOP VIEW

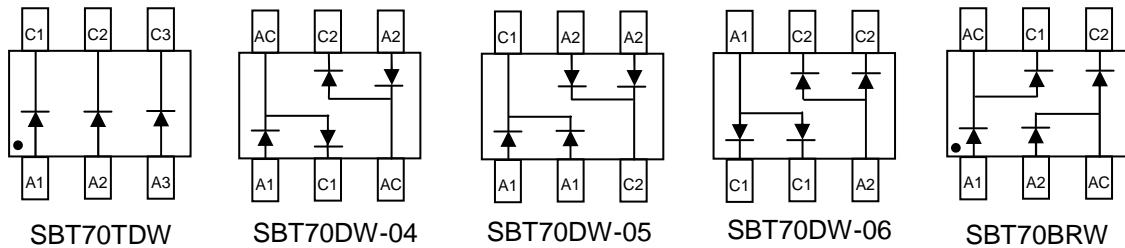

#### ■ Ordering Information (Note 3)

Part Number	Marking Code	Packaging Type	Shipping
			7" Tape & Real
SBT70TDW	SBTGD1	SOT-363	3K
SBT70DW-04	SBTGD2	SOT-363	3K
SBT70DW-05	SBTGD3	SOT-363	3K
SBT70DW-06	SBTGD4	SOT-363	3K
SBT70BRW	SBTGD5	SOT-363	3K

Notes: 3. Website at <http://www.sbt.com.tw>

4. Bulk package in a box form is also available upon request.

5. Day code marking is YM, in which Y represents year (For example: 2005 is marked by 5);

M represents month in a year (For example: March is marked by C; November is marked by K).