

Silicon-Based Technology Corp.

Small-Signal Schottky Barrier Diodes

SBT40D Series

SBT40D series are Schottky Barrier Diodes fabricated by a series of proprietary Schottky barrier patents and technologies (SBT[®]) developed by Silicon-Based Technology Corporation, which exhibit high-performance characteristics for modern switching, conversion and protection applications with high speed and low power consumptions. The package types as described in this data sheet are set forth in routine production; other packages are available upon special orders.

■ Features and Advantages:

- Low forward voltage drop (V_F)
- Low reverse leakage current (I_R)
- Very small conduction power loss
- Very small switching power loss
- Very high switching speed
- Very high reliability

■ Electrical Characteristics : (@ $T_A=25^{\circ}\text{C}$ unless otherwise specified)

Characteristic	Symbol	Min.	Max.	Unit	Test Conditions
Reverse Breakdown Voltage (Note 2)	$V_{(BR)R}$	40	-	V	$I_R=10\mu\text{A}$
Forward Voltage (Note 2)	V_F	-	320 800	mV mV	$I_F=1.0\text{mA}$, $t_p<300\mu\text{S}$ $I_F=40\text{mA}$, $t_p<300\mu\text{S}$
Leakage Current (Note 2)	I_R	-	200	nA	$V_R=30\text{V}$
Total Capacitance	C_T	-	5.0	pF	$V_R=0$, $f=1.0\text{MHz}$
Reverse Recovery Time	t_{rr}	-	5.0	ns	$I_F=I_R=10\text{mA}$, $I_{rr}=0.1 \times I_R$, $R_L=100\Omega$



Silicon-Based Technology Corporation

1F, No. 23, R&D Rd. I, Hsinchu Science Park, Taiwan, R.O.C

Tel : 886-3-5777897

Fax : 886-3-5779832

**■ Maximum Ratings : (@T_A=25°C unless otherwise specified)**

Characteristic	Symbol	Value	Unit
Peak Repetitive Reverse Voltage	V _{RRM}		
Working Peak Reverse Voltage	V _{RWM}	40	V
DC Blocking Voltage	V _R		
RMS Reverse Voltage	V _{R(RMS)}	28	V
Forward Continuous Current (Note 1)	I _{FM}	200	mA
Non-Repetitive Peak Forward Surge Current @t=1.0s	I _{FSM}	600	mA
Power Dissipation (Note 1)	P _d	200	mW
Thermal Resistance Junction to Ambient (Note 1)	R _{θJA}	625	°C/W
Operating Temperature Range	T _j	-55 to +125	°C
Storage Temperature Range	T _{STG}	-65 to +150	°C

- Notes: 1. Device is mounted on FR-4 PC board with a recommended pad layout, which can be found on our website at www.sbt.com.tw
2. Short duration test pulse is used to minimize self-heating effect.

■ Package Data :

- Case: Molded Plastic Material (UL Flammability Classification 94V-0)
- Terminals: Solderable Plated Terminals (MIL-STD-202, Method 208)
- Lead Free Plating (Matte Tin Finish)
- Polarity: See devices configuration below
- Approx. Weight: 0.006 grams
- Package outline and dimensions (see below)

SOT-363

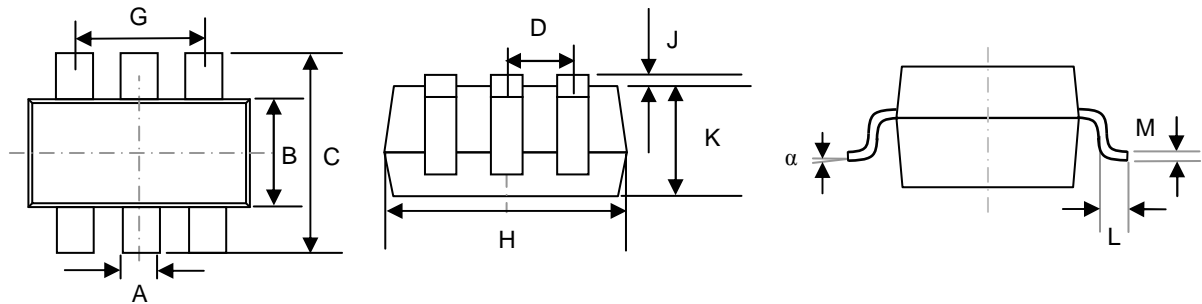

DIMENSIONS (MM)

	A	B	C	D	F	H	J	K	L	M	α
Min.	0.10	1.15	2.00	0.65	0.30	1.80	-	0.90	0.25	0.10	0°
Max.	0.30	1.35	2.20	Nominal	0.40	2.20	0.10	1.00	0.40	0.25	8°

■ Device Configurations :

TOP VIEW

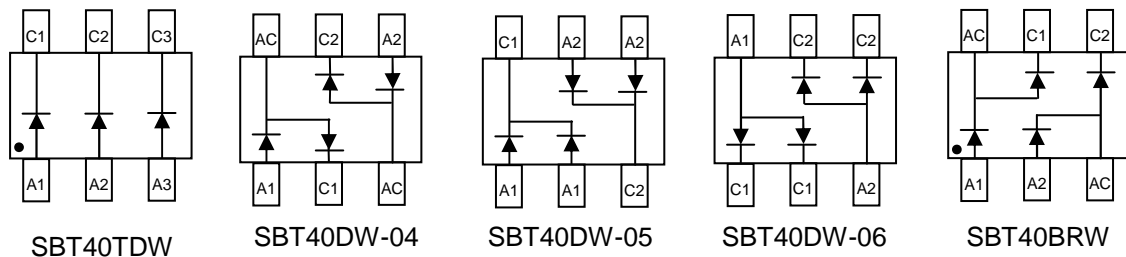

■ Ordering Information (Note 3)

Part Number	Marking Code	Packaging Type	Shipping
			7" Tape & Real
SBT40TDW	SBTDD1	SOT-363	3K
SBT40DW-04	SBTDD2	SOT-363	3K
SBT40DW-05	SBTDD3	SOT-363	3K
SBT40DW-06	SBTDD4	SOT-363	3K
SBT40BRW	SBTDD5	SOT-363	3K

Notes: 3. Website at <http://www.sbt.com.tw>

4. Bulk package in a box form is also available upon request.

5. Day code marking is YM, in which Y represents year (For example: 2005 is marked by 5);

M represents month in a year (For example: March is marked by C; November is marked by K).