

Silicon-Based Technology Corp.

Small-Signal Schottky Barrier Diodes

SBT0340T Series

SBT0340T series are Schottky Barrier Diodes fabricated by a series of proprietary Schottky barrier patents and technologies (SBT[®]) developed by Silicon-Based Technology Corporation, which exhibit high-performance characteristics for modern switching, conversion and protection applications with high speed and low power consumptions. The package types as described in this data sheet are set forth in routine production; other packages are available upon special orders.

■ Features and Advantages:

- Low forward voltage drop (V_F)
- Low reverse leakage current (I_R)
- Very small conduction power loss
- Very small switching power loss
- Very high switching speed
- Very high reliability

■ Electrical Characteristics : (@ $T_A=25^\circ\text{C}$ unless otherwise specified)

Characteristic	Symbol	Min.	Typ.	Max.	Unit	Test Conditions
Reverse Breakdown Voltage (Note 2)	$V_{(BR)R}$	40	-	-	V	$I_R=10\mu\text{A}$
Forward Voltage (Note 2)	V_F	-	260	300	mV	$I_F=1\text{mA}$
Leakage Current (Note 2)	I_R	-	-	1.0	nA	$V_R=10\text{V}$
Total Capacitance	C_T	-	2	-	pF	$V_R=1\text{V}, f=1.0\text{MHz}$



Silicon-Based Technology Corporation

1F, No. 23, R&D Rd. I, Hsinchu Science Park, Taiwan, R.O.C

Tel : 886-3-5777897

Fax : 886-3-5779832

**■ Maximum Ratings : (@T_A=25°C unless otherwise specified)**

Characteristic	Symbol	Value	Unit
Peak Repetitive Reverse Voltage	V _{RRM}		
Working Peak Reverse Voltage	V _{RWM}	40	V
DC Blocking Voltage	V _R		
RMS Reverse Voltage	V _{R(RMS)}	28	V
Forward Continuous Current (Note 1)	I _{FM}	30	mA
Non-Repetitive Peak Forward Surge Current @8.3ms Single half sine-wave superimposed on rated load (JEDEC method)	I _{FSM}	200	mA
Power Dissipation (Note 1)	P _d	150	mW
Thermal Resistance Junction to Ambient (Note 1)	R _{θJA}	833	°C/W
Operating and Storage Temperature Range	T _j , T _{STG}	-40 to +125	°C

- Notes: 1. Device is mounted on FR-4 PC board with a recommended pad layout, which can be found on our website at www.sbt.com.tw
2. Short duration test pulse is used to minimize self-heating effect.

■ Package Data :

- Case: Molded Plastic Material (UL Flammability Classification 94V-0)
- Terminals: Solderable Plated Terminals (MIL-STD-202, Method 208)
- Lead Free Plating (Matte Tin Finish)
- Polarity: See device configurations below
- Approx. Weight: 0.002 grams.
- Package outline and dimensions (see below)

SOT-523

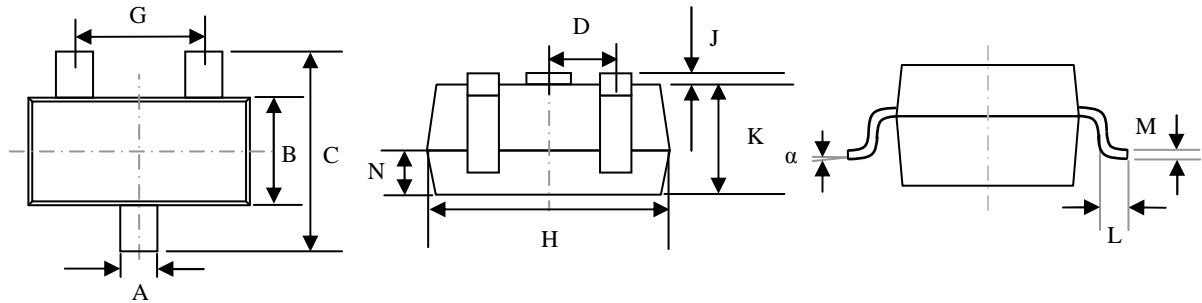

DIMENSIONS (MM)												
	A	B	C	D	G	H	J	K	L	M	N	α
Min.	0.15	0.75	1.45	-	0.90	1.50	0.00	0.60	0.10	0.10	0.45	0°
Max.	0.30	0.85	1.75	-	1.10	1.70	0.10	0.80	0.30	0.20	0.65	8°

■ Device Configurations :

TOP VIEW

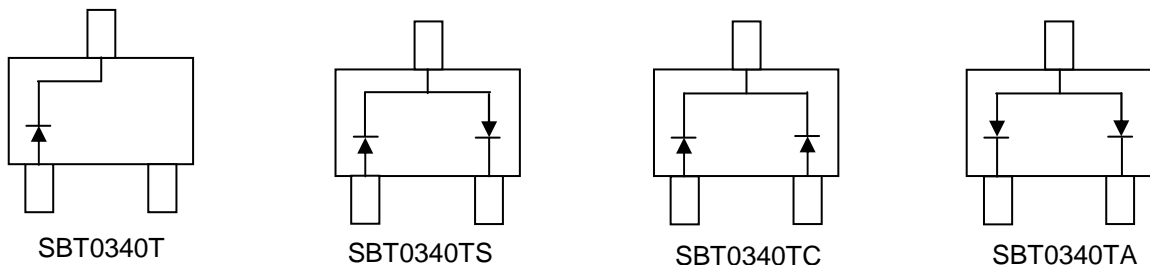

■ Ordering Information (Note 3)

Part Number	Marking Code	Packaging Type	Shipping
			7" Tape & Real
SBT0340T	SBTPT1	SOT-523	3K
SBT0340TS	SBTPT2	SOT-523	3K
SBT0340TC	SBTPT3	SOT-523	3K
SBT0340TA	SBTPT4	SOT-523	3K

Notes: 3. Website at <http://www.sbt.com.tw>

4. Bulk package in a box form is also available upon request.

5. Day code marking is YM, in which Y represents year (For example: 2005 is marked by 5);

M represents month in a year (For example: March is marked by C; November is marked by K).