

Silicon-Based Technology Corp.

Power Schottky Barrier Rectifier

SBT40E20L Series

SBT40E20L series are Schottky Barrier Diodes fabricated by a series of proprietary Schottky barrier patents and technologies (SBT[®]) developed by Silicon-Based Technology Corporation, which exhibit high-performance characteristics for modern switching, conversion and protection applications with high speed and low power consumptions. The package types as described in this data sheet are set forth in routine production; other packages are available upon special orders.

■ Features and Advantages:

- Low forward voltage drop (V_F)
- Low reverse leakage current (I_R)
- Very small conduction power loss
- Very small switching power loss
- Very high switching speed
- Very high reliability

■ Electrical Characteristics : (@ $T_A=25^{\circ}\text{C}$ unless otherwise specified)

Characteristic	Symbol	Min.	Typ.	Max.	Unit	Test Conditions
Reverse Breakdown Voltage (Note 3)	$V_{(BR)R}$	20	-	-	V	$I_R=100\mu\text{A}$
Forward Voltage Drop	V_F	-	-	0.30 0.42	V	$I_F=0.1\text{A}$ $I_F=0.5\text{A}$
Reverse Current (Note 2)	I_R	-	-	50 100	μA	$V_R=10\text{V}$ $V_R=20\text{V}$
Total Capacitance	C_T	-	85	-	pF	$f=1.0\text{MHz}$, $V_R=0\text{V}$



Silicon-Based Technology Corporation

1F, No. 23, R&D Rd. I, Hsinchu Science Park, Taiwan, R.O.C

Tel : 886-3-5777897

Fax : 886-3-5779832

**■ Maximum Ratings : (@T_A=25°C unless otherwise specified)**

Characteristic	Symbol	Value	Unit
Peak Repetitive Reverse Voltage	V _{RRM}		
Working Peak Reverse Voltage	V _{RWM}	20	V
DC Blocking Voltage	V _R		
RMS Reverse Voltage	V _{R(RMS)}	14	V
Forward Continuous Current (Note 1)	I _{FM}	400	mA
Non-Repetitive Peak Forward Surge Current 8.3ms Single half sine-wave superimposed on rated load (JEDEC Method)	I _{FSM}	2	A
Power Dissipation (Note 1)	P _d	225	mW
Typical Thermal Resistance Junction to Ambient (Note 1)	R _{θJA}	444	°C/W
Power Dissipation (Note 2)	P _d	300	mW
Typical Thermal Resistance Junction to Ambient (Note 2)	R _{θJA}	333	°C/W
Operating and Storage Temperature Range	T _j , T _{STG}	-55 to +125	°C

Notes: 1. Part mounted on FR-4 board with recommended pad layout, which can be found on our website at www.sbt.com.tw.

2. Short duration test pulse used to minimize self-heating effect.

■ Package Data :

- Case: Molded Plastic Material (UL Flammability Classification 94V-0)
- Terminals: Solderable Plated Terminals (MIL-STD-202, Method 208)
- Lead Free Plating (Matte Tin Finish)
- Polarity: See device configurations below
- Approx. Weight: 0.008 grams
- Package outline and dimensions (see below)

SOT-23

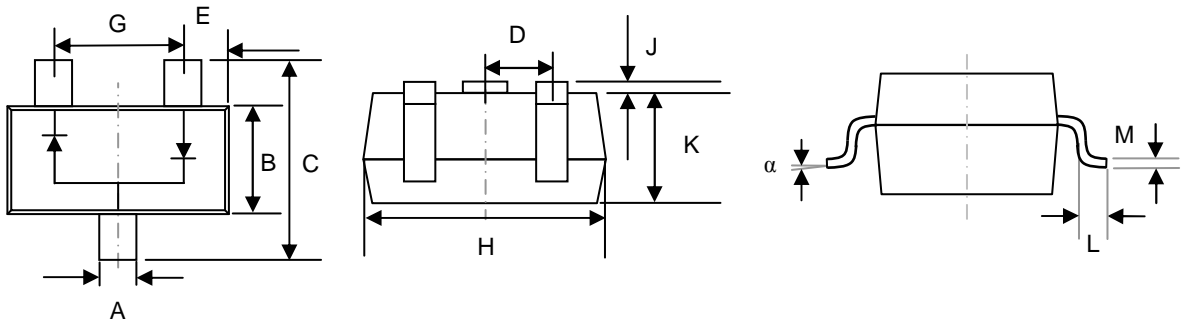
DIMENSIONS (MM)

	A	B	C	D	E	G	H	J	K	L	M	α
Min.	0.37	1.20	2.30	0.89	0.45	1.78	2.80	0.013	0.903	0.45	0.085	0°
Max.	0.51	1.40	2.50	1.03	0.60	2.05	3.00	0.10	1.10	0.61	0.180	8°

■ Ordering Information (Note 3)

Part Number	Marking Code	Packaging Type	Shipping
			7" Tape & Real
SBT40E20L	SBTDBL	SOT-23	3K

Notes: 3. Website at <http://www.sbt.com.tw>

4. Bulk package in a box form is also available upon request.

5. Day code marking is YM, in which Y represents year (For example: 2005 is marked by 5);

M represents month in a year (For example: March is marked by C; November is marked by K).