

Silicon-Based Technology

Very High Speed and Low Power Memory

STATIC CMOS RAM

PRELIMINARY

Description:

The SB61L256AT-XG series products are 32,768-words by 8-bits static RAMs fabricated with advanced 8" wafer submicron CMOS technology. Using unique CMOS peripheral circuits and special poly-load 4-transistor memory cells, the SB61L256AT-XG series products exhibit very high-speed performance with single +5-volt power supply while requiring very low power and no clock or refreshing to operate. The SB61L256AT-XG is packed in a standard 28-pin 8mil*13.4mil TSOP-1.

Features:

- 32,768-word x 8-bit organization
- Single +5-volt power supply
- Fully static operation no clock or refreshing required
- LVTTL-compatible inputs and outputs
- Common I/O capability
- Low power consumption
 - Active: 180/160/140 mA (Max.)
 - Standby: 5 mA
- Very high speed access: 8/10/12 ns (Max.)
- 28-pin plastic 8mil*13.4mil TSOP-1 green package
- Output Enable ($\overline{\text{OE}}$) available for very fast access

Ordering Information:

Part Number	Package	Word Organization	Access Time ns(Max.)	Supply Voltage (Typ.)	Supply Current mA (Max.)	
					Operating	Standby
SB61L256AT-8G	28-Pin Plastic TSOP-1 8mil*13.4mil	32Kx8 bits	8	5V±5%	180	5
SB61L256AT-10G			10		160	
SB61L256AT-12G			12		140	

The information in this document is subject to change without notice



Silicon-Based Technology Corporation

1F, No. 23, R&D Rd. I, Science-Based Industrial Park, Hsinchu, Taiwan, R.O.C.

Tel : 886-35-777897

Fax : 886-35-779832



Preliminary

Pin Configuration: 28-Pin 8mil*13.4mil TSOP-1

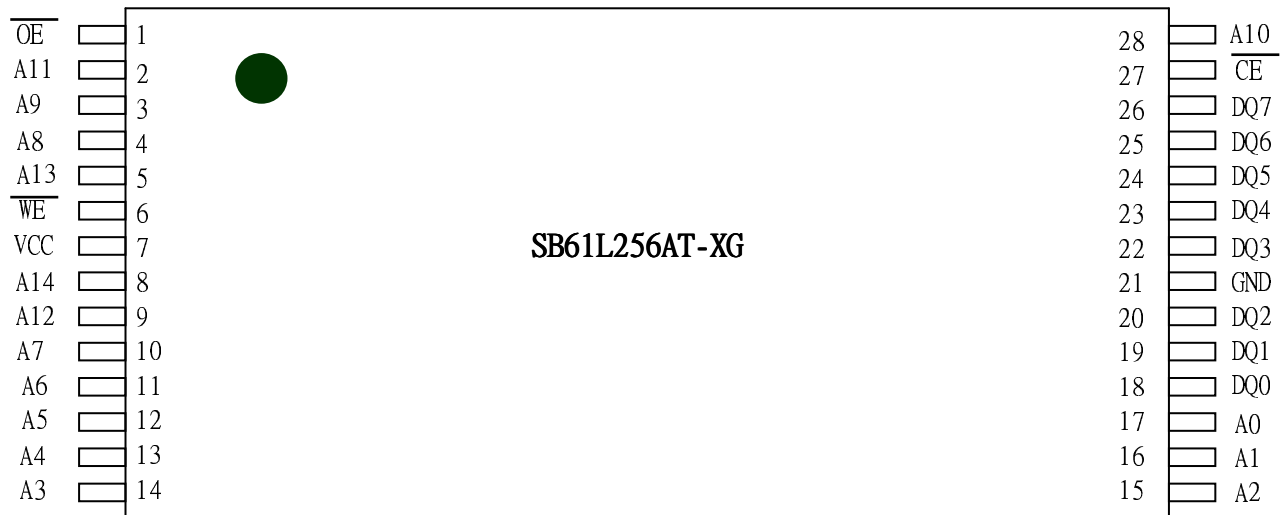

Symbols	Functions
A0~A14	Address Inputs
I/O ₁ ~I/O ₈	Data Inputs/Outputs
$\overline{\text{CS}}$	Chip Select Input
$\overline{\text{WE}}$	Write Enable Input
$\overline{\text{OE}}$	Output Enable Input
V _{DD}	Power Supply
V _{SS}	Ground



Preliminary

Block Diagram:

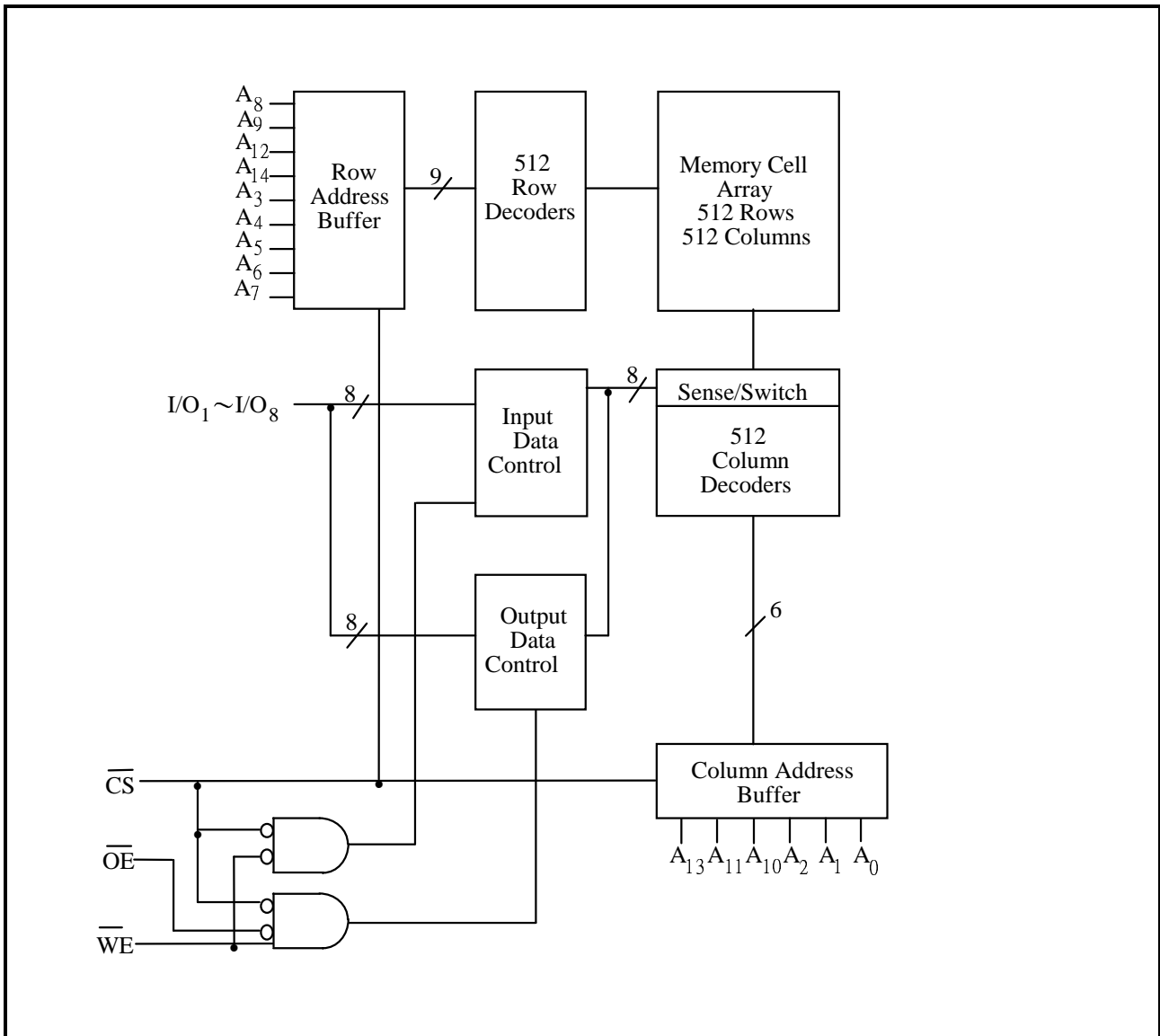

Truth Table:

\overline{CS}	\overline{OE}	\overline{WE}	Mode	I/O ₁ ~I/O ₈	V _{DD} Current
H	X	X	Not Selected	High Z	I _{SB} , I _{SB1}
L	H	H	Output Disable	High Z	I _{DD}
L	L	H	Read	Data Out	I _{DD}
L	X	L	Write	Data In	I _{DD}



Preliminary

DC Characteristics:

Absolute Maximum Ratings

Parameters	Rating	Unit
Supply Voltage to V _{SS}	-0.5 to +7.0	V
Input/Output to V _{SS}	-0.5 to V _{DD} +0.5	V
Allowable Power Dissipation	1.0	W
Storage Temperature	-65 to +150	°C
Operating Temperature	0 to +70	°C

Operating Characteristics:

(V_{DD} = 5V ± 5%, V_{SS} = 0V, T_a = 0 to 70°C)

Parameters	Symbols	Test Conditions	Min.	Typ.	Max.	Unit	
Input Low Voltage	V _{IL}	-	-0.3	-	+0.8	V	
Input High Voltage	V _{IH}	-	+2.6	-	V _{DD} +0.5	V	
Input Leakage Current	I _{LI}	V _{IN} = V _{SS} to V _{DD}	-10	-	+10	μA	
Output Leakage Current	I _{LO}	V _{I/O} = V _{SS} to V _{DD} , \overline{CS} = V _{IH} or \overline{OE} = V _{IH} or \overline{WE} = V _{IL}	-10	-	+10	μA	
Output Low Voltage	V _{OL}	I _{OL} = +8.0mA	-	-	+0.4	V	
Output High Voltage	V _{OH}	I _{OH} = -4.0mA	+2.8	-	-	V	
Operating Power	I _{DD}	\overline{CS} = V _{IL} , I/O = 0 mA Cycle = MIN , Duty = 100%	8	-	-	180	mA
Supply Current			10	-	-	160	mA
			12	-	-	140	mA
Standby Power	I _{SB}	\overline{CS} = V _{IH} , Cycle = MIN Duty = 100%	-	-	15	mA	
Supply Current	I _{SB1}	$\overline{CS} \geq V_{DD} - 0.2V$	-	-	5	mA	

Note: Typical characteristics are measured at V_{DD} = 5V, T_a = 25°C



Preliminary

AC Characteristics:

Capacitances

($V_{DD} = 5V$, $T_a = 25^\circ C$, $f = 1\text{ MHz}$)

Parameters	Symbols	Conditions	Max.	Unit
Input Capacitance	C_{IN}	$V_{IN} = 0V$	6	pF
Input/Output Capacitance	$C_{I/O}$	$V_{OUT} = 0V$	8	pF

Note: These parameters are sampled but not 100% tested.

AC Test Conditions

Parameters	Conditions
Input Pulse Levels	0V to 3V
Input Rise and Fall Times	3 ns
Input and Output Timing Reference Level	1.5V
Output Load	$C_L = 30\text{ pF}$, $I_{OH}/I_{OL} = -4\text{ mA}/8\text{ mA}$

AC Test Loads and Waveforms

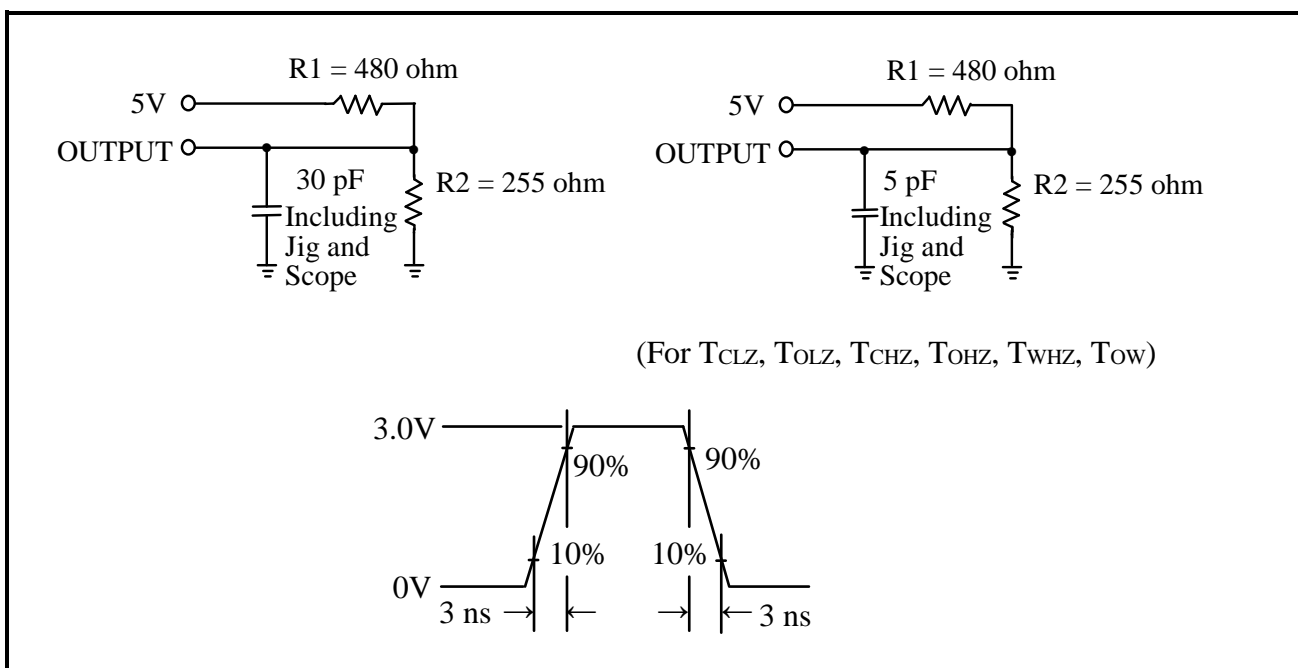



Preliminary

AC Performances:

($V_{DD} = 5V \pm 5\%$, $V_{SS} = 0V$, $T_a = 0$ to $70^\circ C$)

(1) Read Cycle

Parameters	Symbols	SB61L256AT-8G		SB61L256AT-10G		SB61L256AT-12G		Unit
		Min.	Max.	Min.	Max.	Min.	Max.	
Read Cycle Time	T_{RC}	8	-	10	-	12	-	ns
Address Access Time	T_{AA}	-	8	-	10	-	12	ns
Chip Select Access Time	T_{ACS}	-	8	-	10	-	12	ns
Output Enable to Output Valid	T_{AOE}	-	5	-	6	-	7	ns
Chip Selection to Output in Low Z	T_{CLZ}^*	3	-	3	-	3	-	ns
Output Enable to Output in Low Z	T_{OLZ}^*	0	-	0	-	0	-	ns
Chip Deselection to Output in High Z	T_{CHZ}^*	-	4	-	5	-	6	ns
Output Disable to Output in High Z	T_{OHZ}^*	-	4	-	5	-	6	ns
Output Hold from Address Change	T_{OH}	3	-	3	-	3	-	ns

*These parameters are sampled but not 100% tested

(2) Write Cycle

Parameters	Symbols	SB61L256AT-8G		SB61L256AT-10G		SB61L256AT-12G		Unit
		Min.	Max.	Min.	Max.	Min.	Max.	
Write Cycle Time	T_{WC}	8	-	10	-	12	-	ns
Chip Selection to End of Write	T_{CW}	6	-	8	-	10	-	ns
Address Valid to End of Write	T_{AW}	6	-	8	-	10	-	ns
Address Setup Time	T_{AS}	0	-	0	-	0	-	ns
Write Pulse Width	T_{WP}	6	-	8	-	10	-	ns
Write Recovery Time	T_{WR}	0	-	0	-	0	-	ns
Data Valid to End of Write	T_{DW}	4	-	6	-	8	-	ns
Data Hold from End of Write	T_{DH}	0	-	0	-	0	-	ns
Write to Output in High Z	T_{WHZ}^*	-	4	-	5	-	6	ns
Output Disable to Output in High Z	T_{OHZ}^*	-	4	-	5	-	6	ns
Output Active from End of Write	T_{OW}	0	-	0	-	0	-	ns

* These parameters are sampled but not 100% tested



Preliminary

Timing Waveforms

Read Cycle 1
(Address Controlled)

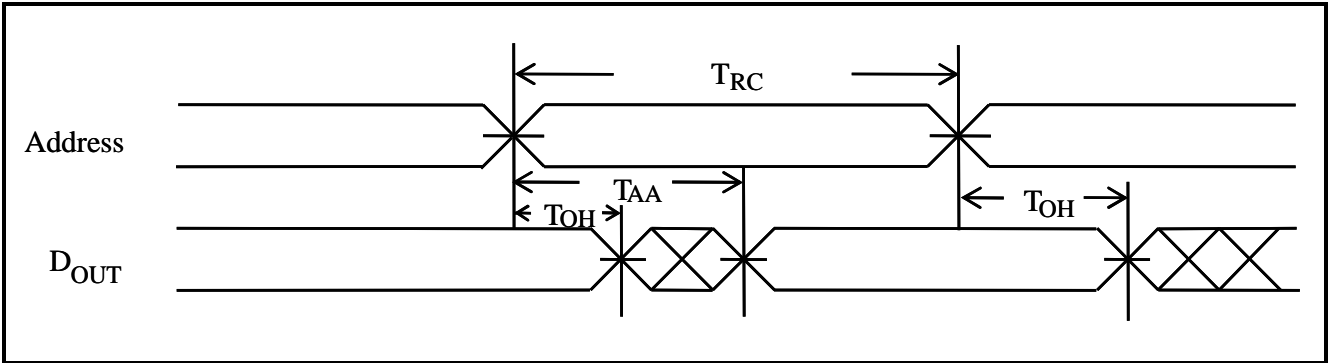

Read Cycle 2
(Chip Select Controlled)

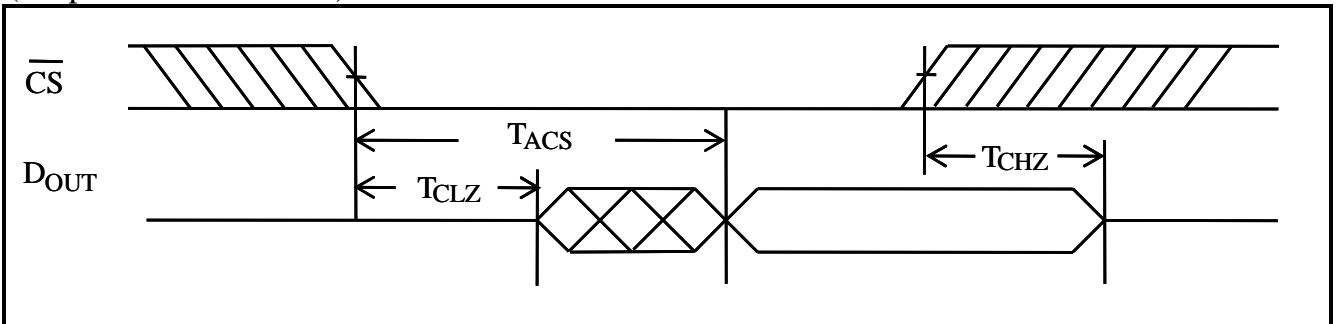

Read Cycle 3
(Output Enable Controlled)

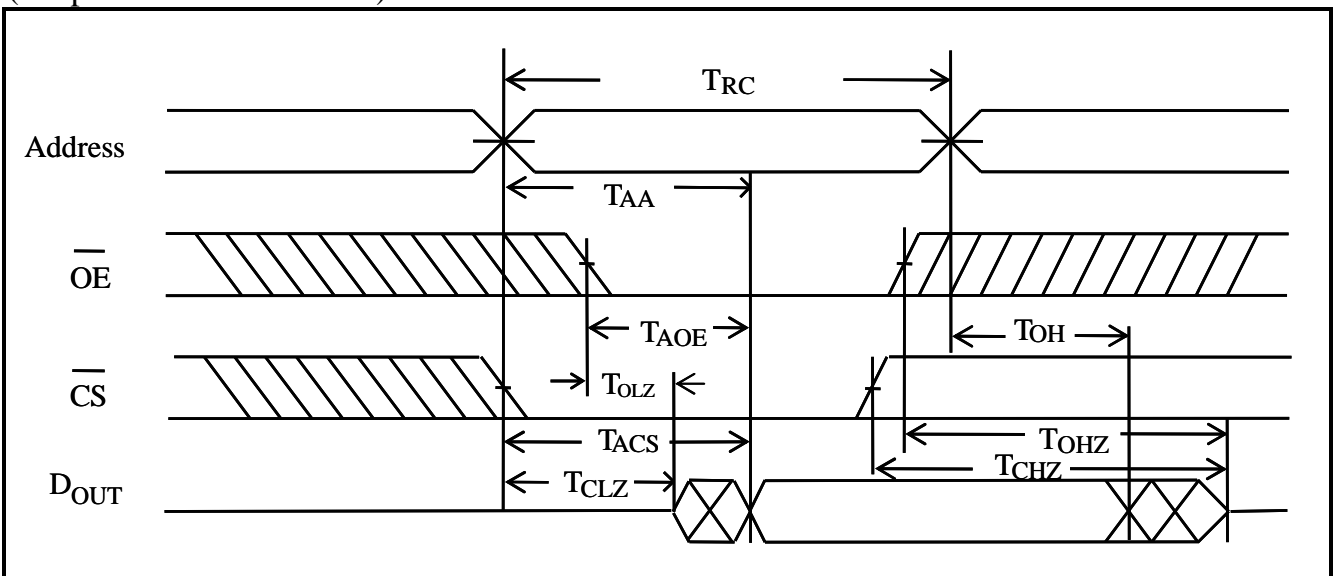

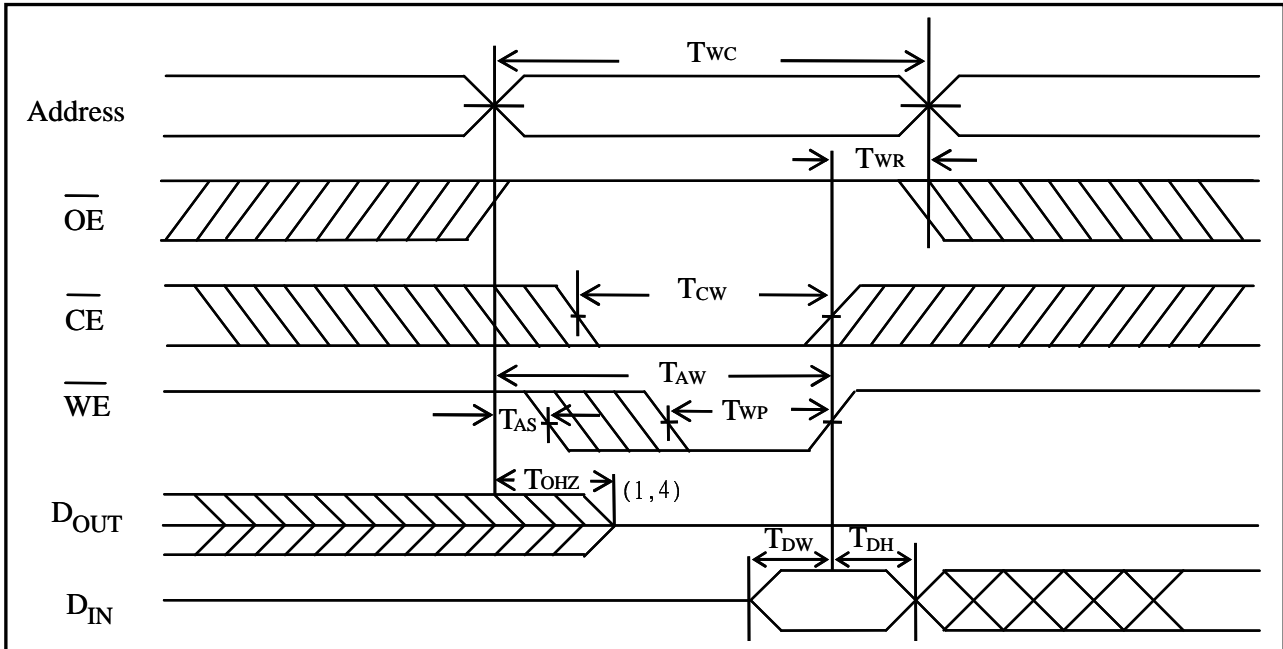
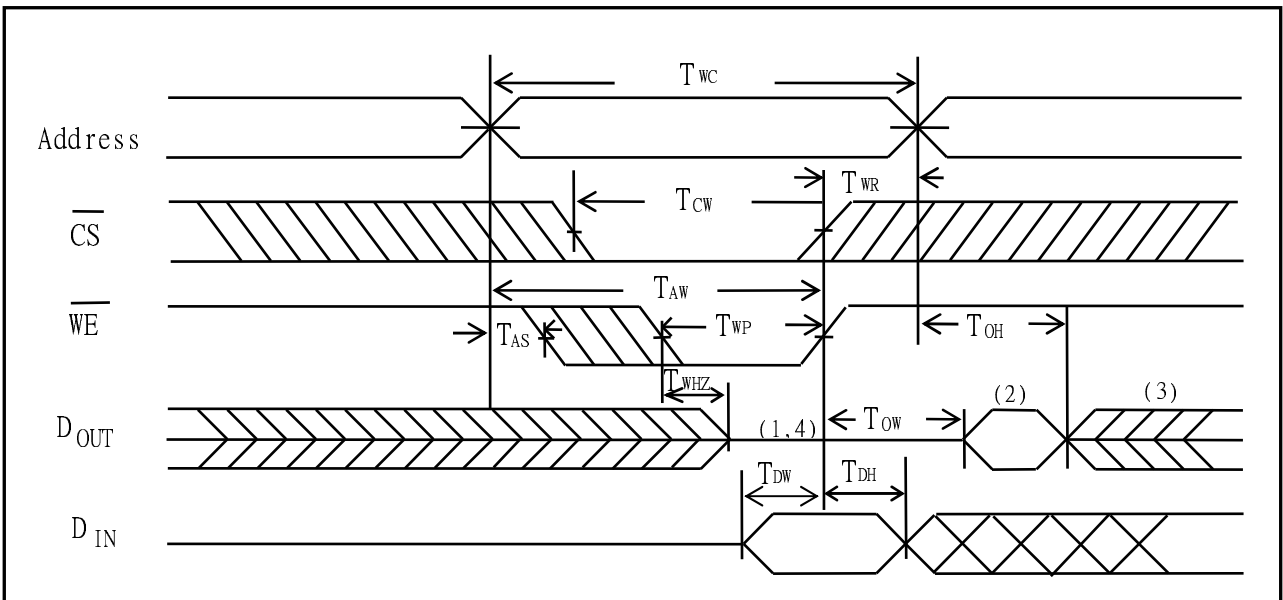

Preliminary

Write Cycle 1
(OE Clock)Write Cycle 2
(OE = VIL Fixed)

Notes:

1. During this period, I/O pins are in the output state, so input signals of opposite phase to the outputs should not be applied.
2. The data output from D_{OUT} are the same as the data written to D_{IN} during the write cycle.
3. D_{OUT} provides the read data for the next address.
4. Transition is measured $\pm 500\text{mV}$ from steady state with $C_L = 5\text{pF}$. This parameter is guaranteed but not 100% tested.