

FEATURES

- High Performance Scientific Camera
 - Hamamatsu S7031 Sensors
 - 512 x 58 to 1024 x 250 active pixels
 - 24 μm x 24 μm pixel size
- Integrated TE Cooling
 - -15 $^{\circ}\text{C}$ from 20 $^{\circ}\text{C}$ ambient
 - Hermetically sealed
 - Temperature controlled to ± 0.1 $^{\circ}\text{C}$
 - Air cooled
- Integrated Digital Signal Processing
 - Utilizes MityDSP technology
 - Can be customized for application specific processing
- Interface Options
 - USB 2.0
 - 100 Mbit Ethernet
- Programmable General Purpose I/O
 - Use as trigger inputs or drive as shutter / frame strobes

APPLICATIONS

- Embedded Instrumentation
- Low Light Imaging Applications
- Raman Spectroscopy
- Portable Scientific Instrumentation
- Astronomy



Figure 1: MityCCD-H7031 with Standard Body

DESCRIPTION

The MityCCD-H7031 family of cameras integrates thermoelectrically cooled high performance CCD sensors suitable for scientific instrumentation with digital signal processing (DSP) capabilities.

An embedded camera rich in features, MityCCD is ready for stand-alone applications. A simple block diagram of the MityCCD camera is illustrated in Figure 2. By integrating a floating point DSP and field programmable gate array into the camera electronics, the MityCCD camera provides the capability to embed application specific code (binning patterns, post processing algorithms, etc.) into a delivered instrument.

The MityCCD uses standard high speed interfaces including 100 Mbit Ethernet and USB 2.0 and eliminates the need for custom interface cards or electronics to a display PC, allowing the use of laptop devices, embedded computers, or (via Ethernet) remote display machines.

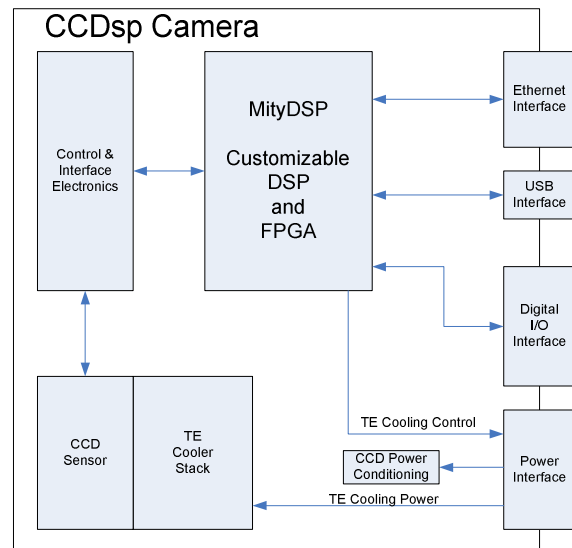

Figure 2: MityCCD Block Diagram

TECHNICAL SPECIFICATIONS

A summary of the imaging performance of the MityCCD-H7031 family of cameras is included below. This family of cameras utilizes sensors from the Hamamatsu S7031 family of CCDs. Detailed datasheets regarding the sensor performance curves for sensitivity, well depth, quantum efficiency and dark current, etc. may be located on the manufacturer's website [1].

PERFORMANCE

	Min	Typical	Max	Units
Active Pixels	-	1024x122	-	H x V
Pixel Size	-	24 x 24	-	W x H ; μm
Imaging Area	-	24.56 x 2.92	-	W x H ; mm
Gain, Setting 1 ²		4.7		e^- per count
Gain, Setting 2 ²		14.2		e^- per count
ADC resolution	-	16	-	bits
Readout Noise @ 500 kHz, Gain 1 / 2	-	12 / 22	18 / 30	e^-
Dynamic Range, Gain 1 / 2	-	27K / 44K	-	
Readout Rate ¹	20	493	1000	kHz
Full Frame Rate	-	3	-	Frames / s
CCD Binned Frame Rate ⁴	-	200	-	Frames / s
USB Link Throughput ³	-	13,000	-	Kbytes / s
Ethernet Link Throughput ³	-	1,000	-	Kbytes / s
Cooling capability below ambient	35	40	-	$^{\circ}\text{C}$
Power Utilization ⁵	8	21	31	Watts
Power Input ⁵	12	18	24	V DC

Table 1: MityCCD-H7031 Performance

Note: Data in Table 1 is specific to the MityCCD-H70311007 camera. The Full Frame Rate and CCD Binned Frame Rate would be faster for the MityCCD-H70310906, MityCCD-H70310907 and MityCCD-H70311006 cameras.

	Typical	Units
Pixel Well Depth, typical	300	$k e^-$ / pixel
Readout Well Depth, typical (for binning)	1000	$k e^-$ / pixel
Dark Current @ -15 $^{\circ}\text{C}$	1.5	e^- / pixel / s

Table 2: S7031 Electrical and Optical Characteristics

Notes:

- 1 – The Readout Rate in a MityCCD stock camera is 493 KHz. The readout rate may be customized for user specific applications, please contact Critical Link, LLC, for details.
- 2 – The MityCCD cameras offset two gain settings, which are user configured via a software setting.
- 3 – Throughput rates assume a back-end PC capable of accepting the data rates provided by the camera.
- 4 – Assumes Full Vertical Binning within the CCD down to 1 output row using USB interface
- 5 – The MityCCD camera must be powered by the MityCCD-PS power supply assembly, which uses a 12-24 DC input in order to generate all necessary voltages to run the camera. The 8 Watt minimum power utilization represents a camera with no TE cooling enabled.

QUANTUM EFFICIENCY

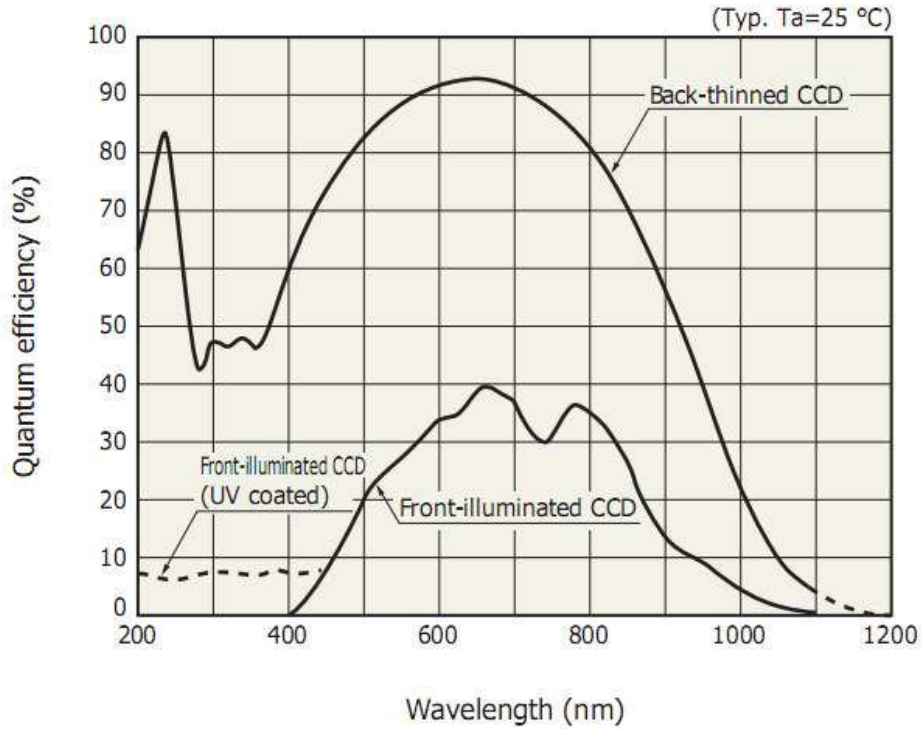

Figure 3: Spectral Response

OPERATING AND STORAGE CONDITIONS

Ambient Temperature Range	0 °C to 30 °C
Humidity	< 80%, Non-Condensing
Storage Temperature Range	-20 °C to 55 °C

Table 3: MityCCD-H7031 Operating and Storage Conditions

ORDERING INFORMATION

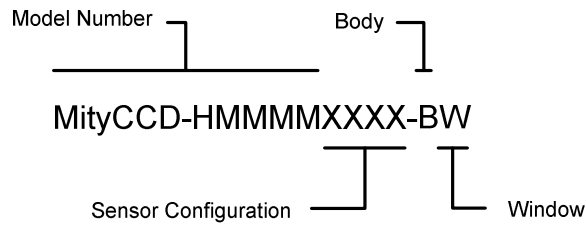

Model Number	Description
MityCCD-H7031	Back-Illuminated

Sensor Config.	Description
0906	512x58
0907	512x122
0908	512x250
1006	1024x58
1007	1024x122
1008	1024x250

Body	Description
A	Standard Body
B	Open Frame – No Flange required
C	Reserved
D	Enclosed Body
E	Reserved

Window	Description
S	AR-coated Sapphire Window

Additional Notes:

1. A MityCCD-H7031 camera also requires a power supply package and a flange package that can be ordered separately. For more information contact Critical Link, LLC for details.
2. A MityCCD-H7031 camera also requires a software package. For more information contact Critical Link, LLC for details.
3. A MityCCD-H7031 camera can be ordered with optional accessories. For more information contact Critical Link, LLC for details.

EXTERNAL DIMENSIONS

Unless otherwise noted, all dimensions are in mm [inches].

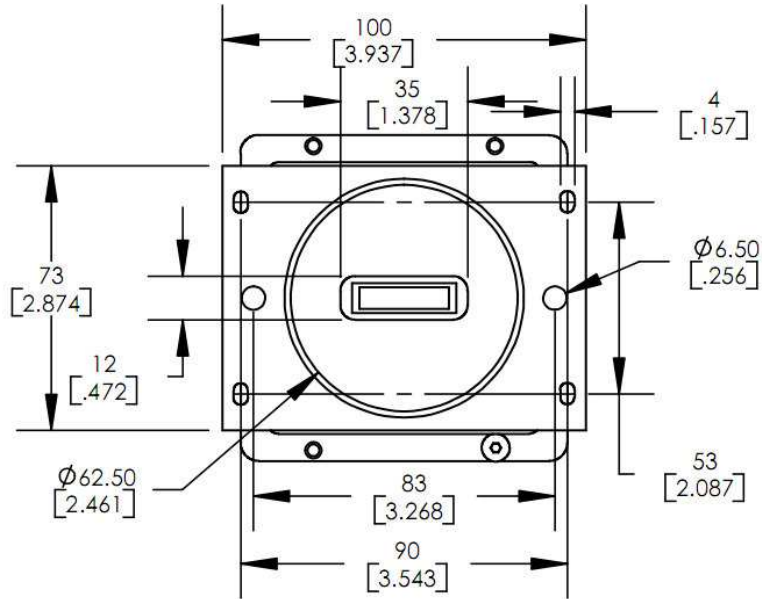

Figure 4: Standard Body (Type A) with Rectangular Flange (Type A) - Front View

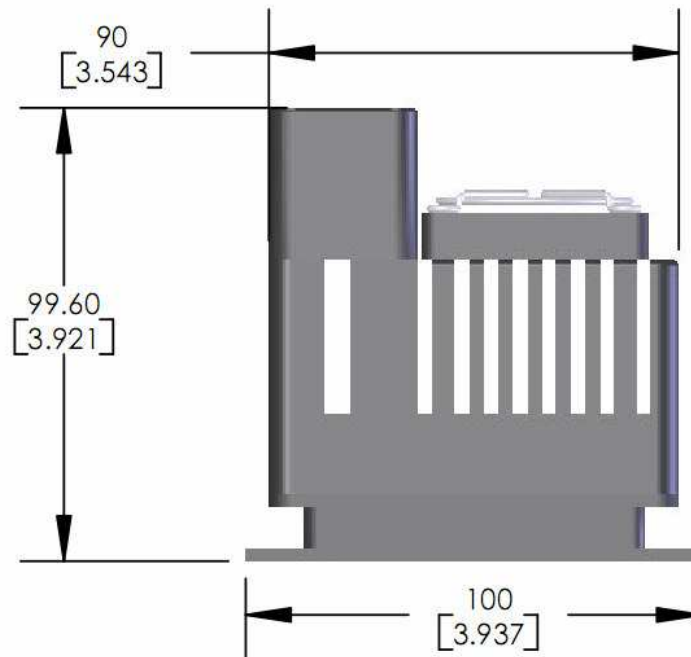

Figure 5: Standard Body (Type A) with Rectangular Flange (Type A) - Side View



Figure 6: Standard Body (Type A) with Rectangular Flange (Type A) - Top View

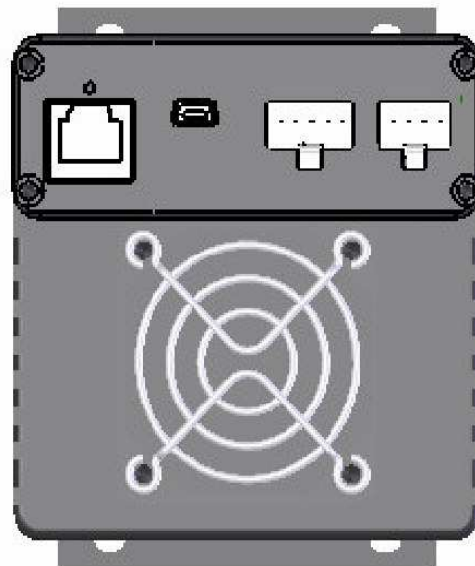

Figure 7: Standard Body (Type A) with Rectangular Flange (Type A) - Back View

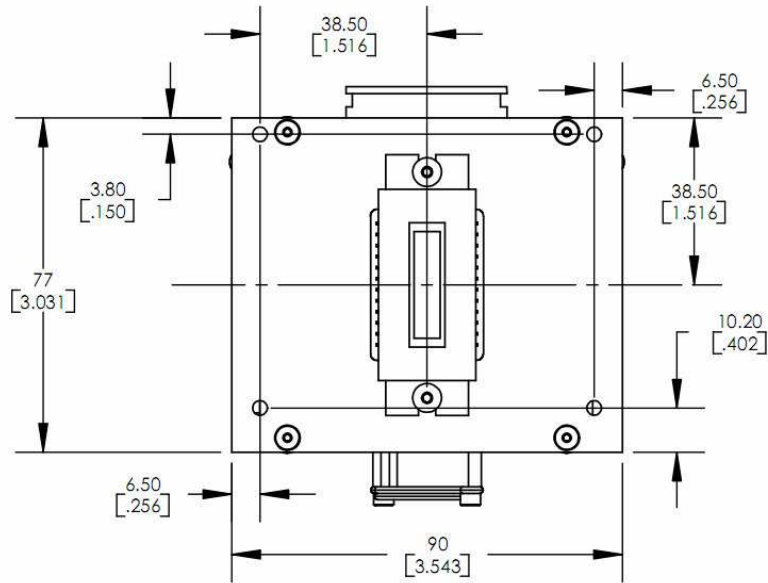

Figure 8: Open Frame Body (Type B) – Front View

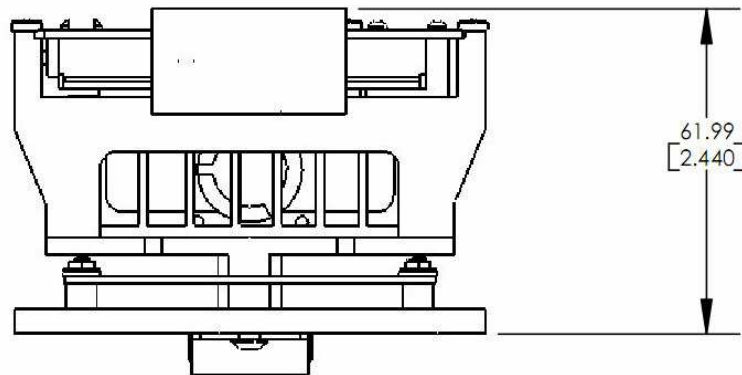

Figure 9: Open Frame Body (Type B) – Top View

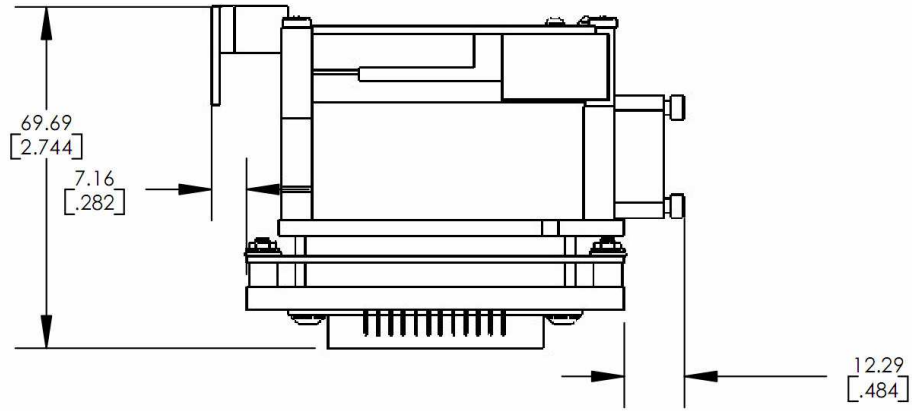

Figure 10: Open Frame Body (Type B) - Side View

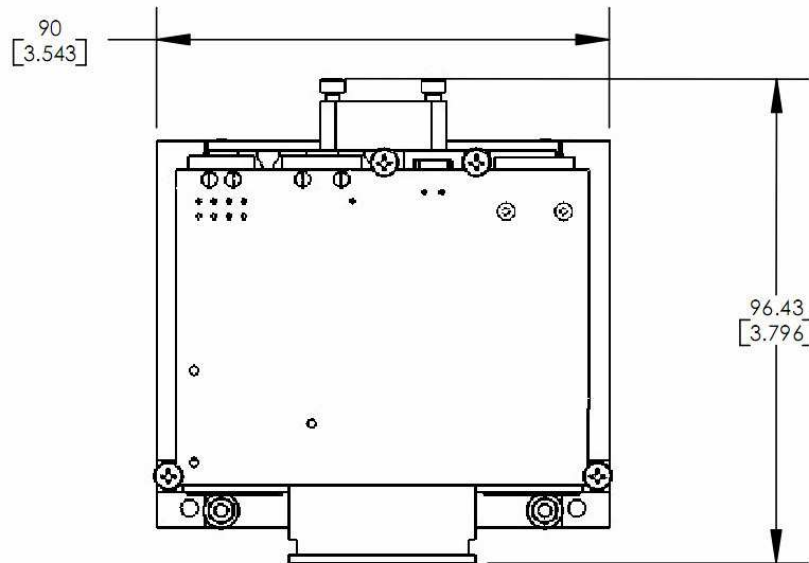

Figure 11: Open Frame Body (Type B) - Back View

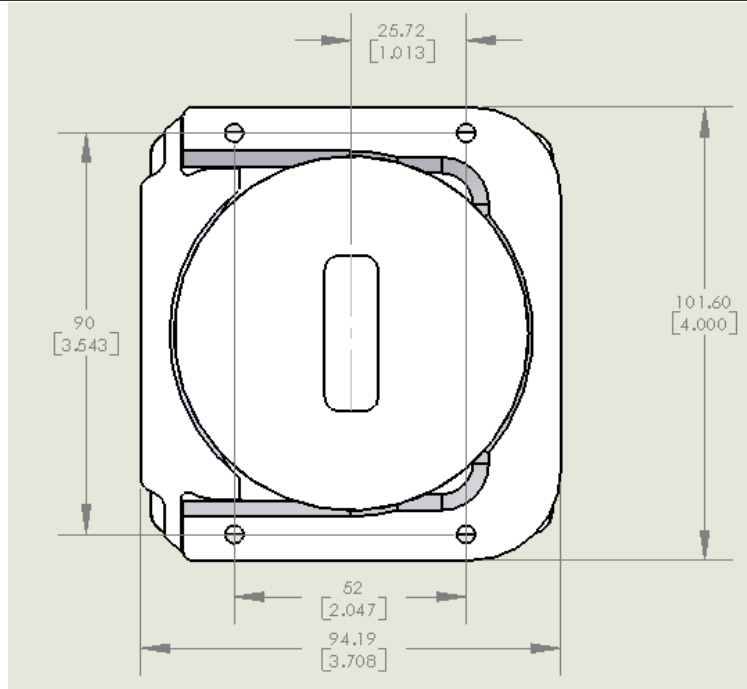

Figure 12: Enclosed Body (Type D) with Split Flange (Type C) – Front View

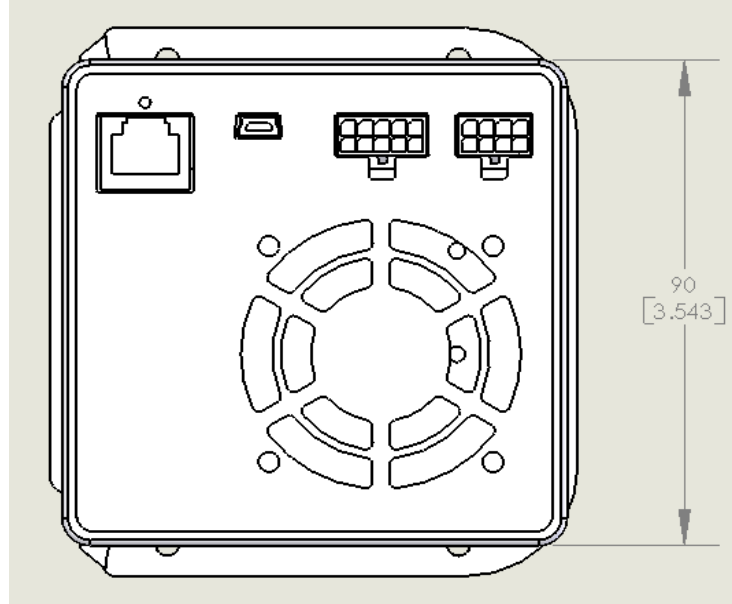

Figure 13: Enclosed Body (Type D) with Split Flange (Type C) - Back View

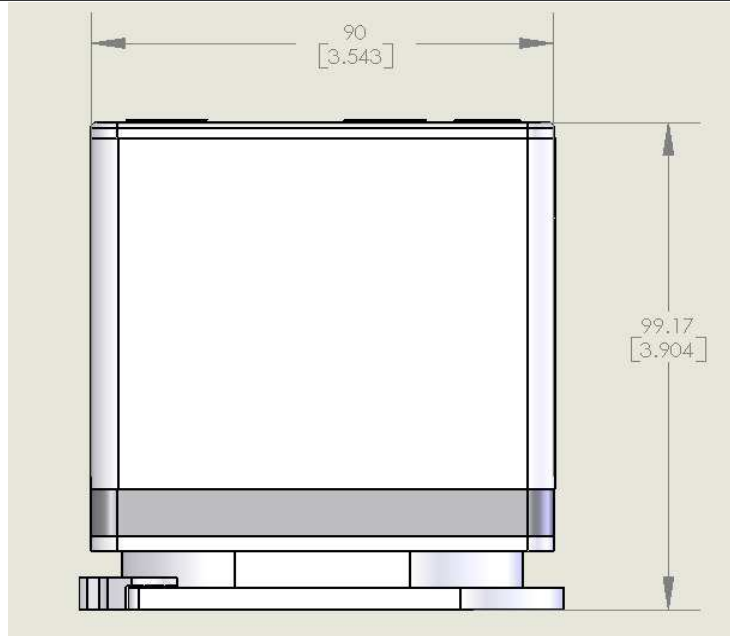

Figure 14: Enclosed Body (Type D) with Split Flange (Type C) - Top View

ELECTRICAL CONNECTIONS

In addition to industry standard Mini USB and 10/100 Mbit based Ethernet RJ-45 communications interface jacks, the MityCCD also provides the following interface connectors.

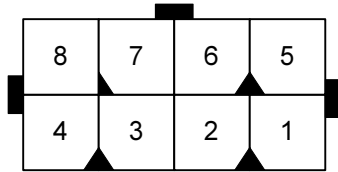

Figure 15: Power Connector ¹ - Rear View

Pin	I/O	Description
1	O	TE Cooler Control
2	I	TE Cooler -V Rtn
3	-	GND
4	I	+6 V (1 Amp Max)
5	I	TE Cooler +V In (7 V at 2 Amps Max)
6	I	+15 V (0.3 Amp Max)
7	I	+32 V (0.04 Amp Max)
8	I	-9 V (0.2 Amp Max)

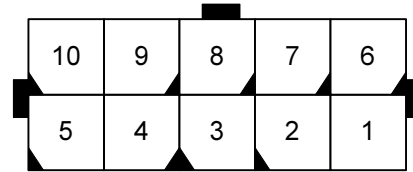

Figure 16: GPIO Connector ² - Rear View

Pin	I/O	Description
1	I/O	General Purpose TTL I/O 3
2	I/O	General Purpose TTL I/O 1
3	O	+5 VD (800 mA Max)
4	I	RS232 RX
5	-	GND
6	-	GND
7	I/O	General Purpose TTL I/O 2
8	I/O	General Purpose TTL I/O 0
9	-	GND
10	O	RS232 TX

Notes:

- 1 – Mating connector is Mfg part# 43025-0800. Please contact Critical Link, LLC for details.
- 2 – Mating connector is Mfg part # 43025-1000. Please contact Critical Link, LLC for details.

REFERENCE

- [1] Hamamatsu Photonics K.K., Solid State Division, "CCD area image sensor S7030/S7031 series,"
Jun 2009
http://jp.hamamatsu.com/resources/products/ssd/pdf/s7030-0906_etc_kmpd1023e16.pdf