

DESCRIPTION

This is a dual high radiance 660 nm visible and 940 nm infrared emitting LED Assembly, designed for medical ratio-metric measurements.

FEATURES

- Visible and infrared power emissions
- High Reliability
- Small surface mount ceramic substrate
- 3-Terminal Common Anode Electrical connection

ABSOLUTE MAXIMUM RATINGS

- Storage temperature..... -40°C to +80°C
- Case operating temperature..... -40°C to +80°C
- Solder temperature..... 240°C, 3 seconds
- Reverse Voltage..... 5 Volts

ELECTRO-OPTICAL CHARACTERISTICS (Case T = 25°C)

PARAMETER	TEST CONDITION	SYMBOL	MIN	TYP	MAX	UNIT
Forward Voltage (660 nm)	If = 20 mA	V _{f1}		1.8	2.4	Volts
Forward Voltage (940 nm)	If = 20 mA	V _{f2}		1.3	1.5	Volts
Reverse Breakdown Voltage (660 nm)	I _r = 10 μA	BVR	5			Volts
Reverse Breakdown Voltage (940 nm)	I _r = 10 μA	BVR	5			Volts
Radiant Flux (660 nm)	If = 20 mA	P _{o1}	1.5	1.9		mW
Radiant Flux (940 nm)	If = 20 mA	P _{o2}	1.0	1.9		mW
Peak Wavelength (660 nm)	If = 20 mA	λ _p	655	660	665	nm
Peak Wavelength (940 nm)	If = 20 mA	λ _p	925	940	955	nm
Spectral Bandwidth (660 nm)	If = 20 mA, FWHM	Δλ		25		nm
Spectral Bandwidth (940 nm)	If = 20 mA, FWHM	Δλ		50		nm
Rise/Fall Time (660 nm)	If = 20 mA	tr/tf		0.8		μsec
Rise/Fall Time (940 nm)	If = 20 mA	tr/tf		0.8		μsec

OUTLINE DIMENSIONS

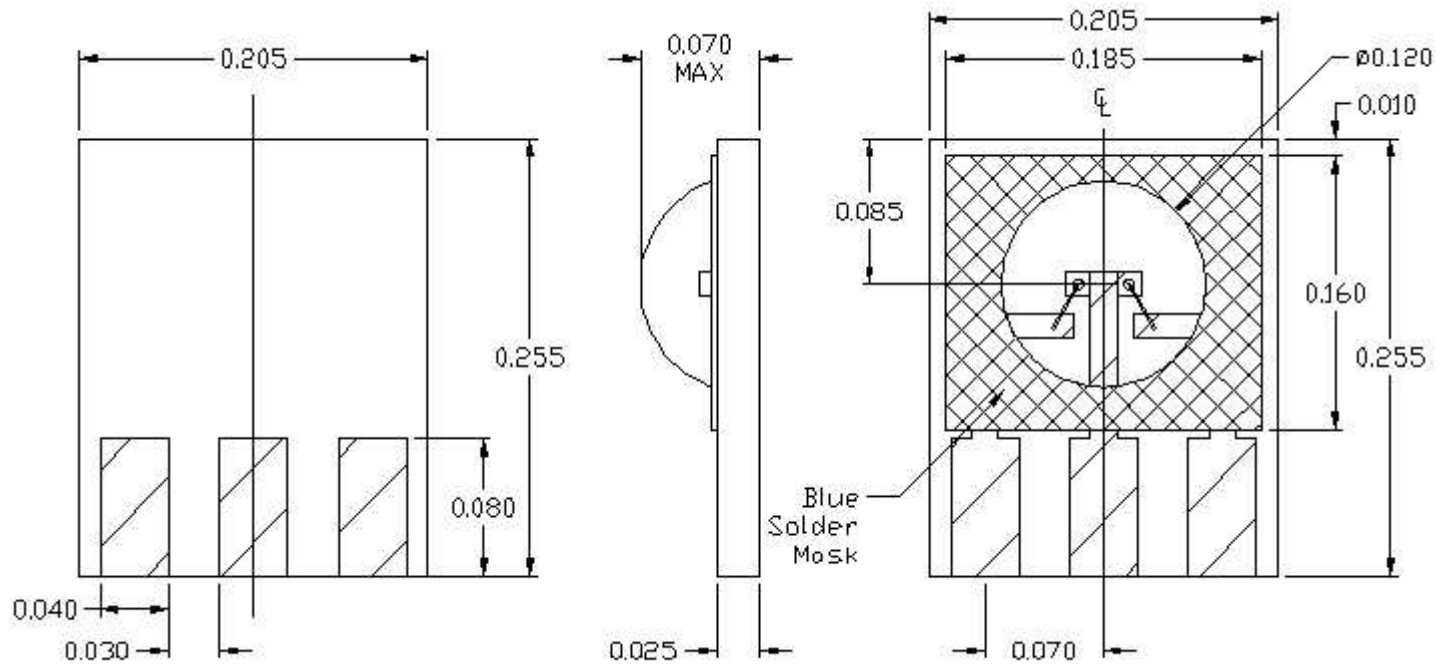

Tolerances are +/-0.005 inches, except as noted

ELECTRICAL SCHEMATIC

