

**DESCRIPTION**

This is a high speed InGaAs detector optimized for fiber optic applications requiring high Responsivity and a fast response time.

**FEATURES**

- High Responsivity
- High Electrical Bandwidth/ Fast response time
- High Reliability/ Hermetic Package
- Similar to AMP 259013-2

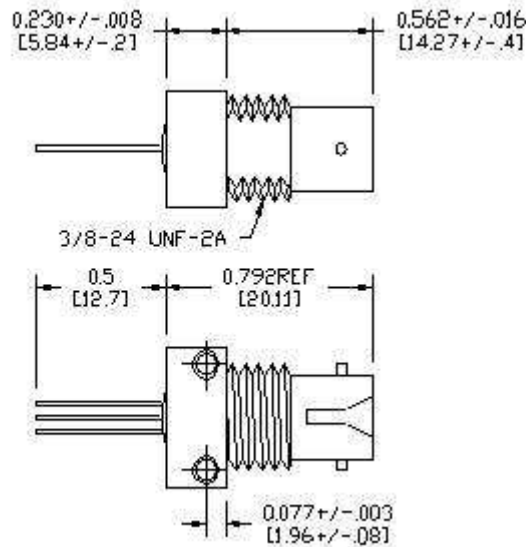
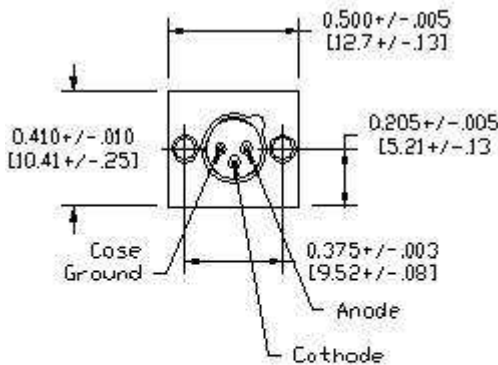

**ABSOLUTE MAXIMUM RATINGS**

- Storage temperature..... -55°C to +125°C
- Case operating temperature..... -40°C to +85°C
- Lead solder temperature..... 260°C, 10 seconds
- Reverse Breakdown Voltage..... 18 Volts

**OUTLINE DIMENSIONS**

Tolerances are +/- 0.005 inches, except as noted  
The case is electrically isolated from the pins.

PARAMETER	TEST CONDITION	SYMBOL	MIN	TYP	MAX	UNIT
Reverse Breakdown Voltage	$I_r = 10 \mu A$	BVR	3.0			Volts
Capacitance	$V_r = 0 V, f = 1 MHz$	C		1.15	1.9	pF
Responsivity (50 $\mu m$ coupled)	$H = 10 \mu W, V_r = 5 Volts$ 50 $\mu m$ Core, $\lambda = 1.3 \mu m$	$R_c$	.75	.85		A/W
Responsivity (62.5 $\mu m$ coupled)	$H = 10 \mu W, V_r = 5 Volts$ 62.5 $\mu m$ Core, $\lambda = 1.3 \mu m$	$R_c$	.65	.8		A/W
Dark Current	$V_r = 5 Volts, H = 0 mW$	$I_d$		2	5	nA
Response Time	10%-90%, $V_r = 5 Volts$	$t_r$ $t_f$		0.5 0.5	1 1	nsec nsec
Spectral Response		$\lambda$	800		1700	nm
Electrical Bandwidth		BWE		1.5		GHz

ELECTRO-OPTICAL CHARACTERISTICS (Case T = 25°C)